

# Digital Kaizen Guidebook



---

---

The Asian Productivity Organization (APO) is an intergovernmental organization that promotes productivity as a key enabler for socioeconomic development and organizational and enterprise growth. It promotes productivity improvement tools, techniques, and methodologies; supports the National Productivity Organizations of its members; conducts research on productivity trends; and disseminates productivity information, analyses, and data. The APO was established in 1961 and comprises 21 members.

#### APO Members

Bangladesh, Cambodia, Republic of China, Fiji, Hong Kong, India, Indonesia, Islamic Republic of Iran, Japan, Republic of Korea, Lao PDR, Malaysia, Mongolia, Nepal, Pakistan, Philippines, Singapore, Sri Lanka, Thailand, Turkiye, and Vietnam.

---

---



# DIGITAL KAIZEN GUIDEBOOK



DIGITAL KAIZEN GUIDEBOOK

Satoshi Komatsu served as the chief expert.

First edition published in Japan  
by the Asian Productivity Organization  
1-24-1 Hongo, Bunkyo-ku  
Tokyo 113-0033, Japan  
[www.apo-tokyo.org](http://www.apo-tokyo.org)

© 2024 Asian Productivity Organization

The views expressed in this publication do not necessarily reflect the official views of the Asian Productivity Organization (APO) or any APO member.

All rights reserved. None of the contents of this publication may be used, reproduced, stored, or transferred in any form or by any means for commercial purposes without prior written permission from the APO.

Designed by Urban Connections Co., Ltd.



# CONTENTS

FOREWORD	VII
<b>SECTION 1 INTRODUCTION</b>	<b>1</b>
Chapter 1.1 Foreword	1
Chapter 1.2 Structure of this Guidebook	2
Chapter 1.3 Digital Kaizen	2
1.3.1 What is Digital Kaizen?	2
1.3.2 DX and Kaizen	3
1.3.3 Digital Innovation Trends in the Manufacturing Industry	4
Chapter 1.4 Ability to Conceptualize Digitalization	6
1.4.1 What is the Ability to Conceptualize Digitalization?	6
1.4.2 Knowledge of Digitalization	6
1.4.3 The Philosophy of Kaizen	7
Chapter 1.5 Reskilling	8
<b>SECTION 2 IOT BASICS</b>	<b>10</b>
Chapter 2.1 What is IoT?	10
Chapter 2.2 Bridging the Real World and Cyberspace	11
Chapter 2.3 Various Sensors Used in Factories	12
Chapter 2.4 Microcontrollers Used in IoT	14
Chapter 2.5 IoT Wireless Area Network	15
Chapter 2.6 LPWA (Low-Power Wide-Area)	16
Chapter 2.7 Cloud Computing and IoT Platforms	17
Chapter 2.8 AWS, Azure, Google Cloud Platform	19
Chapter 2.9 How to Store Data	21
Chapter 2.10 Data Visualization	23
Chapter 2.11 Sending Alerts	25
Chapter 2.12 Programming	26
2.12.1 Programming of IoT devices	26
2.12.2 Language Characteristics	27
2.12.3 Integrated Development Environment (IDE)	27
2.12.4 Using GitHub	29
2.12.5 No Code/Low Code	30
Chapter 2.13 AI in Manufacturing	32
Chapter 2.14 Machine Vision	33
2.14.1 Traditional Machine Vision and the Rise of AI	34
2.14.2 Machine Vision Image Preprocessing	34
2.14.3 Neural Network	38
2.14.4 Convolution Neural Network	40
2.14.5 YOLO	42

<b>SECTION 3</b>	<b>DIGITAL KAIZEN CASE STUDIES</b>	<b>44</b>
<b>Chapter 3.1</b>	<b>Legacy Equipment Retrofit Case Study: Production Control and Abnormality Detection in an Auto Parts Company</b>	<b>44</b>
3.1.1	Importance of Retrofit in Kaizen	44
3.1.2	Current Status and Issues of Company A's Automotive Parts Plant	45
3.1.3	Digital Kaizen Initiatives and Effectiveness	47
3.1.4	Future Prospects: Next Kaizen	53
3.1.5	Digital Technologies Used	53
<b>Chapter 3.2</b>	<b>Production Management Kaizen Case Study: Visualization and Utilization of Production Data in a Confectionery Factory</b>	<b>55</b>
3.2.1	Importance of production control in Kaizen	55
3.2.2	Company B's Confectionery Factory: Current Status and Issues	56
3.2.3	Digital Kaizen Initiatives and Effectiveness	59
3.2.4	Future Prospects: Next Kaizen	63
3.2.5	Digital Technologies Used	63
<b>Chapter 3.3</b>	<b>Environmental Improvement Case Study: Visualization of Environmental Parameters at a Cosmetics Company</b>	<b>64</b>
3.3.1	Importance of Measuring Environmental Parameters in Kaizen	64
3.3.2	Company C's Cosmetics Factory: Current Status and Issues	65
3.3.3	Digital Kaizen Initiatives and Effectiveness	67
3.3.4	Future Prospects: Next Kaizen	74
3.3.5	Digital Technologies Used	74
<b>Chapter 3.4</b>	<b>Inventory Management Case Study: Introducing an RFID System in a Hand Tools Company</b>	<b>76</b>
3.4.1	Importance of Inventory Management in Kaizen	76
3.4.2	Current Status and Issues of Company D's Production Process	77
3.4.3	Digital Kaizen Initiatives and Effectiveness	80
3.4.4	Digital Technologies Used	85
<b>Chapter 3.5</b>	<b>Equipment Monitoring Case Study: Quality Improvement by Introducing an Equipment Monitoring System to an Ultrasonic Gel Manufacturing Company</b>	<b>86</b>
3.5.1	Importance of Equipment Monitoring in Kaizen	86
3.5.2	Company E's Current Status and Issues	87
3.5.3	Digital Kaizen Initiatives and Effectiveness	89
3.5.4	Digital Technologies Used	92
<b>Chapter 3.6</b>	<b>System Integration Case Study: Integrating Various Data and Equipment at a Metal Stamping Company</b>	<b>92</b>
3.6.1	Importance of Information System Integration in Kaizen	92
3.6.2	Current Status and Issues of Company F's Production Process	93
3.6.3	Digital Kaizen Initiatives and Effectiveness	95
3.6.4	Digital Technologies Used	102

<b>SECTION 4 LEARN THE TECHNOLOGY FOR DIGITAL KAIZEN</b>	<b>103</b>
<b>Chapter 4.1 Building the Raspberry Pi Development Environment</b>	<b>104</b>
4.1.1 What is the Raspberry Pi?	104
4.1.2 Raspberry Pi Family	105
4.1.3 Raspberry Pi board configuration	106
4.1.4 Raspberry Pi Software Development	107
4.1.5 Initial Settings of the Raspberry Pi	109
4.1.6 VNC setup and activation	112
4.1.7 Using Visual Studio Code	117
4.1.8 Python Programming for Beginners	124
<b>Chapter 4.2 Visualization of Equipment Operating Conditions Using Sensors</b>	<b>128</b>
4.2.1 Importance of Visualization of Operating Conditions in Kaizen	128
4.2.2 Types of Sensors Used for Object Detection	128
4.2.3 Creating a Parts Counting System	129
4.2.4 Proximity Sensor MDS-F4-5V [74]	130
4.2.5 Connecting the MDS-F4-5V to the Raspberry Pi	131
4.2.6 Python Programming of the Parts Counting System	132
<b>Chapter 4.3 Acquisition of Environmental Sensor Data</b>	<b>134</b>
4.3.1 Importance of Environmental Data Acquisition in Kaizen	134
4.3.2 Available Environmental Sensors	135
4.3.3 Configuration of Environmental Parameter Acquisition System	135
4.3.4 Understanding the Environmental Sensor BME280	136
4.3.5 Connecting the BME280 to the Raspberry Pi	137
4.3.6 Overview of I2C Interface	138
4.3.7 Preparing for Cloud Service and Programming	138
4.3.8 Python Program to Process Environmental Parameters	141
4.3.9 Start the Program Periodically	143
4.3.10 Observation of Environmental Parameters by the Cloud Service	144
<b>Chapter 4.4 Saving Environmental Sensor Data to a File</b>	<b>145</b>
4.4.1 Export to CSV file on Raspberry Pi	145
<b>Chapter 4.5 Real-Time Synchronization of Data</b>	<b>150</b>
4.5.1 Export to InfluxDB Cloud	151
<b>Chapter 4.6 Data Visualization and Alert Transmission</b>	<b>162</b>
4.6.1 Visualization and Alerting with InfluxDB Cloud and Grafana Cloud	163
<b>Chapter 4.7 Anomaly Detection Using Sensors</b>	<b>180</b>
4.7.1 Importance of Anomaly Detection in Kaizen	180
4.7.2 Creating a Motor Anomaly Detection System	180
4.7.3 Driving a DC Motor by PWM	181
4.7.4 Connecting the motor, current sensor INA219, and the Raspberry Pi	182
4.7.5 Anomaly Detection Strategy	183
4.7.6 Python Programming of the Anomalies Detection System	187

<b>SECTION 5 HOW TO PROCEED WITH A PROJECT</b>	<b>190</b>
<b>Chapter 5.1 How to Proceed with a Project Suitable for Digital Kaizen</b>	<b>190</b>
<b>Chapter 5.2 How to Proceed with Agile Project Management</b>	<b>193</b>
5.2.1 Origins of Scrum	193
5.2.2 Characteristics of Scrum	193
5.2.3 Overview of the Scrum Framework	194
5.2.4 Project Promotion Structure in Scrum and an Image of How It Is Applied to Digital Kaizen	196
5.2.5 How to Proceed with a Project in Scrum and an Image of How it is Applied to Digital Kaizen	200
<b>Chapter 5.3 Deliverables at Project Completion</b>	<b>208</b>
5.3.1 Purpose of Systemization	208
5.3.2 System Configuration Diagram	209
5.3.3 List of Devices Used	209
<b>Chapter 5.4 How to proceed when using an IT vendor</b>	<b>211</b>
5.4.1 How to Select a Vendor	211
5.4.2 Important Points on How to Conclude a Contract	212
<b>REFERENCES</b>	<b>213</b>
Section 1-4	213
Section 5	217
<b>APPENDIX</b>	<b>222</b>
1. Glossary	222
2. Frequently Asked Questions	229
3. Hardware, software, and cloud-based services used in Section 4	231
<b>LIST OF FIGURES</b>	<b>232</b>
<b>LIST OF CONTRIBUTORS</b>	<b>236</b>

# FOREWORD

In the ever-evolving landscape of digital technologies, the pursuit of continuous improvement should not be taken for granted. Kaizen, the famous Japanese philosophy which emphasizes continuous improvement, must stay as the fundamental approach of any organization who embarks on digital transformation. Hence, the combination of digital and kaizen offers a structured approach to enhance processes, systems, and outcomes in the digital realm particularly for small and medium-sized enterprises (SMEs) in manufacturing sector.

With the support of a special cash grant from the Government of the Republic of China (ROC), the Asian Productivity Organization (APO) collaborated with China Productivity Center (CPC) and Japan Productivity Center (JPC) in developing a new training manual known as “Digital Kaizen Guidebook.” It aims to enhance the capability of productivity and kaizen experts by adding knowledge on digital tools and applications. This guidebook serves as a comprehensive guide for individuals and organizations embarking on the journey of digital transformation. It is designed to equip readers with the knowledge, tools, and techniques necessary to foster a culture of perpetual enhancement in their digital practices.

Through practical insights, case studies from the ROC and Japan, and actionable strategies, this guidebook explains the principles of Digital Kaizen and empowers readers to implement them effectively within their own contexts. From cultivating a mindset of continuous improvement to leveraging a simple but effective IoT tools and methodologies, each chapter offers invaluable guidance for navigating the application of digital technologies and continuous improvement.

I commend the group of experts from the CPC and the JPC for their dedication in developing this guidebook. It is my sincere hope that this guidebook serves as a catalyst for transformative change, inspiring individuals and organizations alike to embrace the spirit of Digital Kaizen and embark on a journey of inclusiveness, innovation and productivity growth.

Dr. Indra Pradana Singawinata  
Secretary-General



# SECTION 1 INTRODUCTION

## Chapter 1.1 Foreword

Covid-19 has accelerated digitalization in various industries, and the manufacturing industry is no exception. While robots and other new technologies have been promoted, the introduction of IoT will make it possible to visualize manufacturing processes, remotely detect abnormalities in equipment, and manage inventory in an appropriate environment. In addition, by converting work that used to rely on workers' intuition into data and analyzing it, more accurate business based on the data will become possible. This leads to improved quality and more efficient machine operation. In this way, digitization can make a significant contribution to improving productivity in the manufacturing industry.

However, many SMEs that make up 98% of businesses in the Asia-Pacific region and support the economies of APO member countries are struggling to take the first step towards digitalization. The JPC has provided support and conducted workshops related to digitalization of SMEs in the manufacturing sector and recognized the challenges these companies face. The reality is that many SMEs have limited financial and human resources for digitalization, and even if they have introduced digital equipment, it is difficult for them to continue to use it.

There is a risk of not being able to fully utilize the implemented digital equipment if the focus becomes "digitalization" itself rather than addressing the company's challenges. To achieve digitalization in SMEs, it is essential to diagnose the current situation, identify challenges, and have the capability to introduce appropriate digital equipment for addressing those challenges. In other words, it is important to introduce digital equipment for "kaizen" and further connect it to digital transformation (DX), as explained in Chapter 1.1.

Some may think that there is no need for an in-house team if they outsource and implement systems through system integrators. However, without properly assessing their own operations and introducing a system that matches their company, the system may unnecessarily become complex or turn into a black box. There may be a loss of the ability to customize the system to specific requirements. Additionally, many SMEs may face difficulties in terms of funding for implementing such systems. To achieve appropriate digitalization that meets the needs of the actual operations with limited investment, it is essential for the introducing company to have knowledge about digital technologies. In this guidebook, we will introduce relatively affordable IoT tools and focus on methods for data acquisition and visualization. By implementing IoT systems themselves, understanding deepens, and they can achieve autonomous and operation-specific digitalization.

This guidebook is intended for company representatives and consultants involved in enhancing productivity in the manufacturing industry. Specifically, it aims to enable kaizen consultants to gain knowledge of digital technologies, utilize them in kaizen, further deepen their understanding through individual learning, and create the foundation for achieving DX. Ultimately, it is expected to assist numerous SMEs in APO member economies who are striving to achieve digitalization and DX.

This guidebook was collaboratively developed by the CPC and the JPC. Profound gratitude is extended to Yamanashi Industrial Technology Center and Mr. Yasuki Nagata, Professional Engineer (Electrical & Electronics Engineering,) Yamanashi Industrial Technology Junior College, Japan for their invaluable contributions and cooperation.

## Chapter 1.2 Structure of this Guidebook

This guidebook consists of four parts. In Section 2, you will learn what you need to know about devices and networks as the foundation of IoT. In Section 3, you will learn about case studies of companies in Japan and the ROC that have adopted digital technology and implemented kaizen. In Section 4, you will learn how to actually introduce digital devices based on the digital technologies used in the case studies in Section 3. Section 5 explains how to proceed with system development when conducting kaizen activities incorporating digital technology, using the framework of the agile project management method “Scrum.”

## Chapter 1.3 Digital Kaizen

### 1.3.1 What is Digital Kaizen?

This guidebook is based on the new concept of “Digital Kaizen [1, 2].” We define “Digital Kaizen” as follows.

“Digital Kaizen actively integrates rapidly evolving digital technologies into kaizen activities and fully exploits its capabilities to achieve digital transformation and digital optimization.”

Kaizen that leads to successful DX cannot be handled within the scope of traditional analog kaizen. In addition, it requires a deep understanding of digital technology and the ability to apply it. Therefore, this guidebook proposes the “Digital Kaizen” concept and aims to train “Digital Kaizen Consultants” who embody the concept.

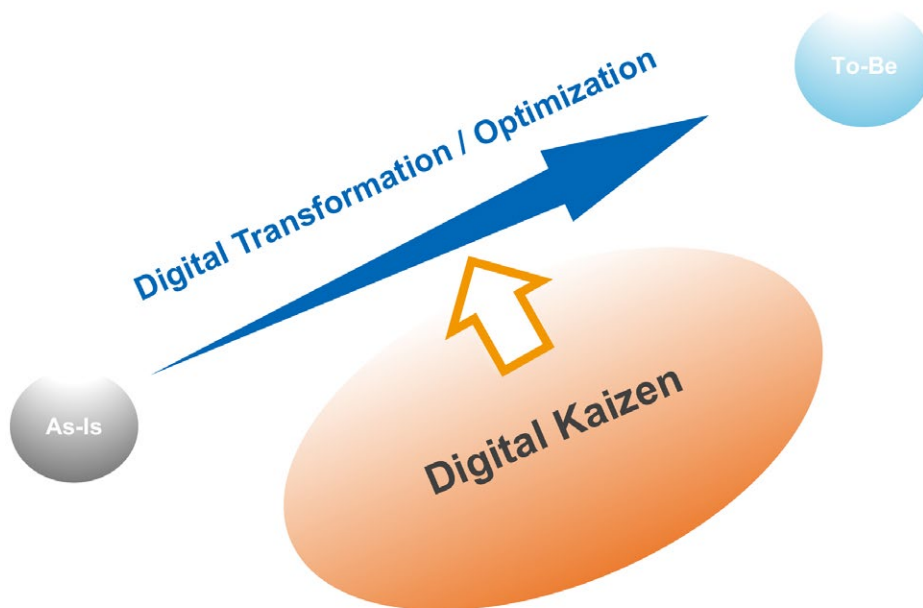



### 1.3.2 DX and Kaizen

Let's look at the relationship between digital transformation / digital optimization and kaizen mentioned above.

First, while there are several definitions of DX (digital transformation), the following definition by the Japanese government will be used for these guidelines. [3]

“DX is the process by which a company, responding to the rapid changes in its business environment, based on the needs of customers and society, transforms its products, services, and business models, as well as its operations, organization, business processes, corporate culture, and tradition, using data and digital technology, thereby eventually establishes a competitive advantage.”

There is also a similar concept called digital optimization. Digital optimization refers to streamlining business processes and improving productivity, even if it does not lead to business model transformation and is considered a preliminary step to DX. In some cases, continuous digital optimization leads to achieving DX. In other cases, digital optimization is required to achieve DX. In the following, DX is described as including the concept of digital optimization.

Kaizen, on the other hand, is the continuous, step-by-step improvement of business processes. The essence of this is to cultivate a kaizen mindset in everyone from management to front-line personnel, which seeks to discover problems, propose solutions, implement improvements, and increase efficiency, quality, and productivity.

Despite different concepts, DX and kaizen are deeply interrelated in achieving improvement and innovation. The relationship between the two is explained in detail below.

- Kaizen will facilitate the adoption of advanced technologies.  
Advanced technologies and data-driven approaches are often used in performing DX. In this case, a certain amount of investment is involved, and the organization must decide whether the investment is worth the expected benefits. Kaizen makes it easier for organizations to invest by clearly showing them where to apply them, what real-time data to collect, and what analysis to use to make steady improvements.
- Kaizen maximizes return on investment.  
In the DX process, kaizen enables the organization to implement continuous, step-by-step improvements, maximizing the benefits of investments in advanced technology.
- Changing corporate culture and climate and continuous learning  
In the process of implementing DX, there is often a need to innovate the corporate culture and climate and continuously learn new technologies and methods. This is consistent with the kaizen mindset of constant improvement, acceptance of change, and learning in our daily work.
- Achieving stable sustainability over the long term  
DX involves major changes in business models, processes, cultures, and organizational structures. Kaizen is essential to ensure that this is not a one-time event but a continuous process of continual improvement.

- Achieving stable sustainability over the long term  
Successful DX is achieved when employees at all levels actively participate in DX and overcome resistance to change. Kaizen provides a framework that enables employees to discover DX opportunities, devise innovative methods, and overcome challenges.

In other words, “there is no DX success without kaizen.”

### 1.3.3 Digital Innovation Trends in the Manufacturing Industry

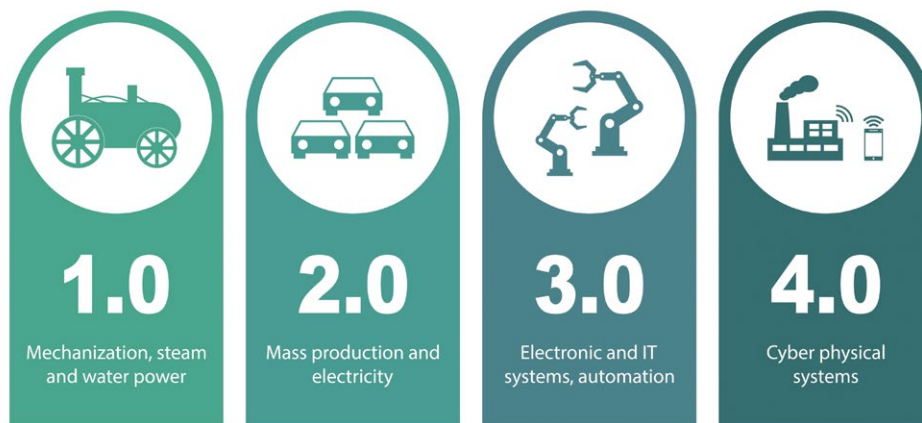

Four industrial revolutions are said to have occurred in the past.

- First Industrial Revolution (18th to early 19th century): The invention of the steam engine and the spinning and weaving machine led to a shift from manual to mechanical work.
- Second Industrial Revolution (late 19th to early 20th century): rapid industrialization and urbanization occurred with the development of the internal combustion engine, electricity, telephones, telegraph, and steel.
- Third Industrial Revolution (20th century): The advent of digital technologies such as computers, robots, and the Internet led to major advances in automation in the manufacturing industry. Information services emerged, and the importance of “knowledge” in manufacturing increased.
- Fourth Industrial Revolution (21st century and beyond): AI, IoT, big data, quantum computing, and advanced wireless communications characterize this revolution. In manufacturing, interconnectivity, automation, machine learning, and real-time data enable smart factories. This phase has been specifically dubbed “Industry 4.0,” and countries worldwide are working to make it a reality.

What is clear from these four industrial revolutions is that those who adapt to and take advantage of disruptive new technologies will prosper, and those who do not will decline.

Rapid digitalization, especially since the Third Industrial Revolution, has significantly impacted the manufacturing industry’s survival and development. We have seen concrete facts that companies or countries that lag in digitalization lose competitiveness while companies that have spearheaded digitalization develop by leaps and bounds. This is why DX has been advocated in recent years,

and the need for business transformation through digital technology has been focused on, regardless of the company's size.

In particular, the development of generative AI, which has become a hot topic since around 2022, is expected to spur this trend more and more.

Therefore, SMEs are at an overwhelming disadvantage compared to large enterprises with much financial and human resources. However, if SMEs do not engage in DX, they will continue to decline.

However, as shown in Figure 1, the smaller the size of a company, the less likely it is to engage in DX.

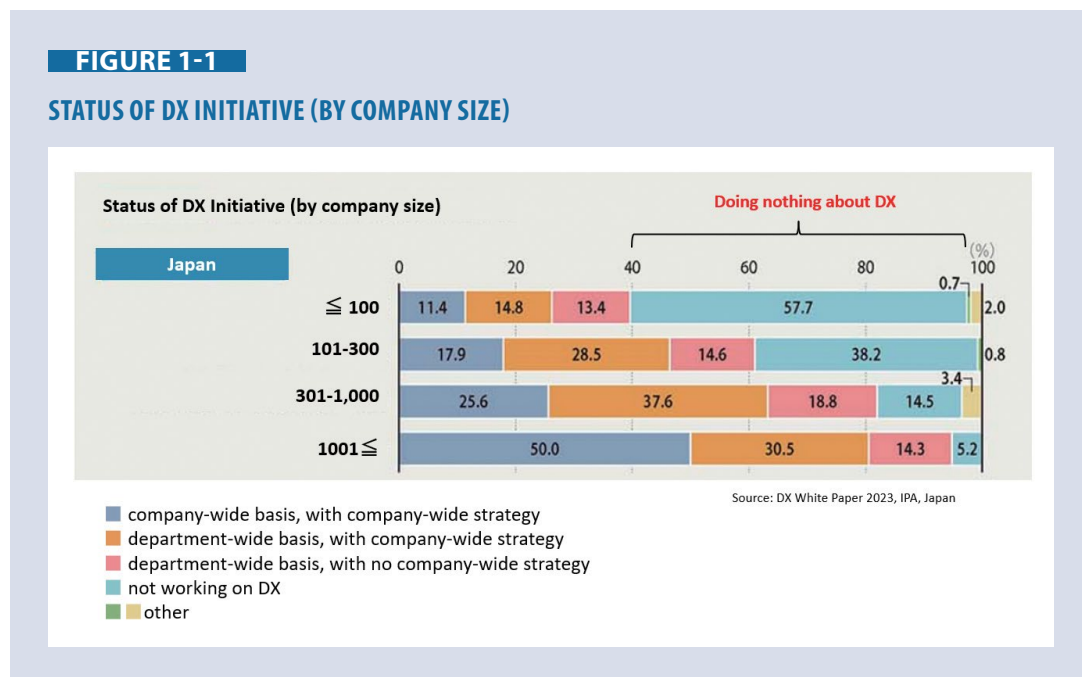

Traditionally, kaizen has significantly contributed to improving productivity in small SMEs. This is because one aspect of kaizen is to increase productivity through human ingenuity while reducing investment. As the importance of digital technology is increasingly recognized alongside the advancement of AI, human ingenuity or the kaizen mindset is becoming more and more important, not less. In other words, the Digital Kaizen concept is essential for SMEs that need to curb their investments.

## Chapter 1.4 Ability to Conceptualize Digitalization

### 1.4.1 What is the Ability to Conceptualize Digitalization?

So, what capabilities are needed to implement Digital Kaizen? In this guideline, the comprehensive capability to implement Digital Kaizen is called the “ability to conceptualize digitalization” and is defined as follows.

This ability is:

“To understand the corporate philosophy, the environment surrounding the company, and the company itself, by organically combining digital technology and kaizen, to build a company-wide or factory-wide digitalization roadmap, and to support and execute projects to realize the roadmap.” (Figure 2)

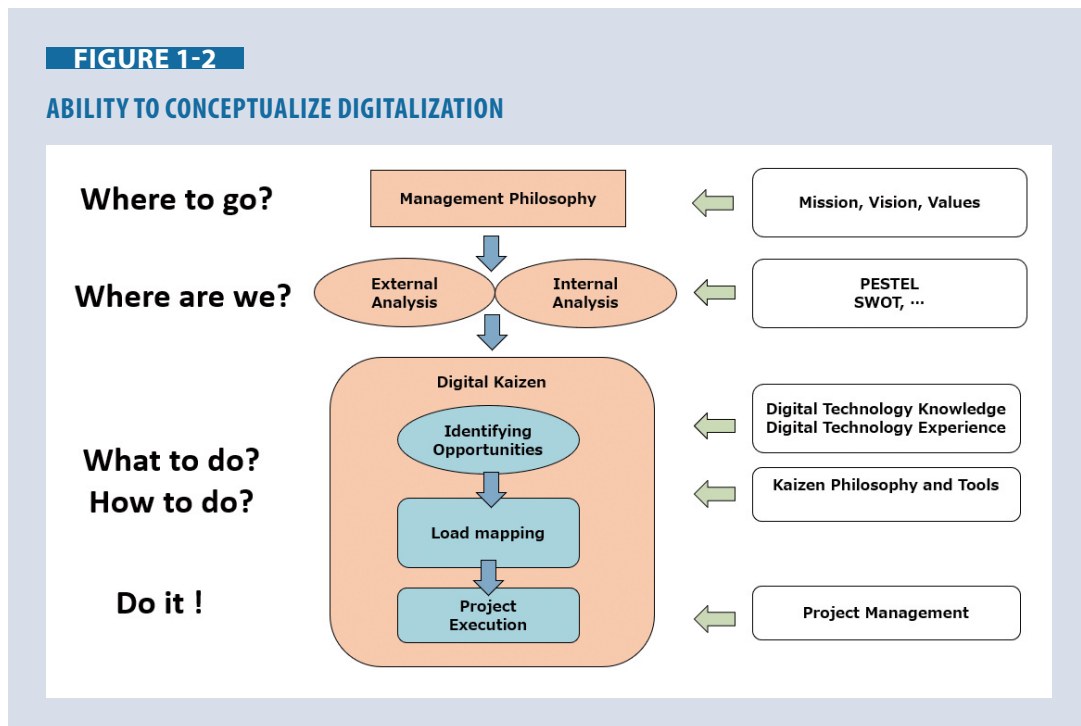

In other words, digitalization conceptual capability is a concept that combines digital knowledge and kaizen to create a great synergy.

The ability to conceptualize digitalization is a skill that should be possessed regardless of one’s position in the business (management, consultant, field leader, or person in charge). However, it contains extensive and in-depth content, which makes it quite laborious to study exhaustively. Therefore, instead of trying to master everything, changing the place of emphasis depending on each position is better. One approach is for management to focus on basic digital knowledge and kaizen philosophy, for field personnel to focus on practical digital skills and kaizen methods and know-how, and for consultants and field leaders to focus on project management.

### 1.4.2 Knowledge of Digitalization

The capabilities required for Digital Kaizen include “basic digital knowledge,” “practical digital skills,” and “project management.” (Figure 2)

- First, the **basic digital knowledge** includes the following items.
  - Fundamentals of computer software/hardware
  - Basic knowledge of sensors and devices
  - Basic knowledge of communication technology
  - Basic knowledge of big data and AI

It should be noted that, unlike mere IT, it includes extensive knowledge of hardware, communications, sensors, and production equipment.

- Next, **practical digital skills** refer to more specific competencies and experiences that can practice/support the application of basic digital knowledge to the field. For example, the following items could be raised.
  - Ability to determine what to measure and how to measure it, and to select sensors and other devices according to the manufacturing process.
  - Ability to select an appropriate microcontroller and plan data collection strategies.
  - Ability to design and write programs using computer languages.
  - Ability to build an IoT system using appropriate cloud services.

- The third is **project management**.

The ability to conceptualize digitalization also includes the knowledge, ability, and experience to plan and execute kaizen projects. Unlike traditional kaizen, Digital Kaizen involves many elements of IT system development and requires project management accordingly. For example, the following items can be raised.

- Agile project management
- Outsourcing management
- Budget and contract management

This guideline proposes the adoption of Scrum as an agile project management method suitable to Digital Kaizen.

### 1.4.3 The Philosophy of Kaizen

Another key factor in the ability to conceptualize digitalization is kaizen.

This guideline is intended for those who already have some knowledge of kaizen, but let's look back now on the philosophy of kaizen.

- **Participation by all:**  
Everyone in an organization, from top management to front-line employees, has unique perspectives and experiences. Kaizen emphasizes everyone's participation in the improvement process to draw on these perspectives and get the best ideas.
- **Continuous, incremental improvement:**  
Kaizen emphasizes the power of small, incremental changes. Over time, these small changes accumulate and lead to major improvements. Such continuous activity is also the driving force behind fundamental reform.

- **Use of data:**  
Decisions about what to improve must be based on data and evidence, not assumptions and feelings. This will ensure that improvements are realistic and measurable.
- **People-centered:**  
Kaizen emphasizes that the success of a project is deeply connected to the well-being, growth, and active participation of the people involved. Rather than machines and processes innovating and improving on their own, it is people who drive change, and people are the most valuable assets in any kaizen effort.
- **Small group activities:**  
Kaizen emphasizes small group activities. Employees gather spontaneously in small groups to address problems or suggest improvements in their immediate work environment. The idea behind these groups is that those closest to the work often have the deepest insight into the issues and potential solutions.
- **Empowerment:**  
Employees are empowered to identify problems and propose solutions. When employees feel a sense of their roles and responsibilities, they are more motivated to contribute positively and seek ways to improve.
- **Standardization:**  
Once a new method is determined to be effective, standardize it. This will ensure that improvements are maintained and serve as the basis for further improvements.
- **Use of visual tools:**  
Data visualization plays a pivotal role in kaizen. This is because kaizen emphasizes evidence-based decision-making, and visual tools can simplify and make complex data sets easier to understand, leading to insights.
- **Challenge the status quo:**  
Even when things seem to be working well, kaizen challenges existing processes and looks for ways to improve them further. Even if a process seems “good enough now,” there is always a better way.

Looking at the philosophy of kaizen in this way, we can see that it is very compatible with digital concepts. IT keywords such as data-driven, data-sharing, and visualization have already appeared in this philosophy, and cutting-edge technologies such as IoT, big data, and AI are expected to make kaizen even more effective.

### Chapter 1.5 Reskilling

Reskilling is extremely important in the context of Digital Kaizen. While the essence of Kaizen does not change with time, digital technology is changing rapidly. In other words, without learning new technologies through reskilling, the ability to conceptualize digitalization will be outdated.

The importance of reskilling can be summarized as follows.

- (1) **Responding to technological advances:** The manufacturing sector is experiencing a significant shift toward digital technologies such as IoT, big data, AI, robotics, and advanced analytics. These technologies are increasingly transforming traditional manufacturing. Employees and consultants implementing Digital Kaizen need to constantly reskill to operate, maintain, and optimize these digital tools effectively.
- (2) **Enhancing competitive advantage:** Statistics show that companies that invest in retraining their employees are more agile and better able to adapt to changes in the marketplace. This adaptability enables companies to increase productivity, reduce costs, and innovate, thereby increasing their competitiveness.
- (3) **Job retention and creation:** While some jobs will be eliminated by digitization, many new jobs will be created. Reskilling will allow existing employees to transition into these new roles, thereby preserving jobs and reducing the need for outside employment.
- (4) **Improving employee morale and retention:** Investing in employee development shows that the company cares about its employees. This will have the effect of increasing job satisfaction and morale and decreasing turnover. This is a critical point for small and medium-sized companies suffering from a shortage of human resources.

**Driving Innovation:** Employees familiar with the latest technology are more likely to contribute to discovering novel kaizen points and propose innovative solutions that lead to new products, services, and more efficient processes.

In conclusion, the importance of reskilling cannot be underestimated in Digital Kaizen. Kaizen consultants must constantly reskill as a form of self-improvement, and companies must win in the digital world by investing in employee reskilling and fostering a culture of continuous learning and adaptability. These guidelines were written in light of the importance of reskilling.

# SECTION 2 IOT BASICS

## The goals for this section are:

- To understand the basic concepts and terminology of IoT technology required for subsequent sessions.
- To understand the basics of IoT system development required for subsequent sessions.

## Chapter 2.1 What is IoT?

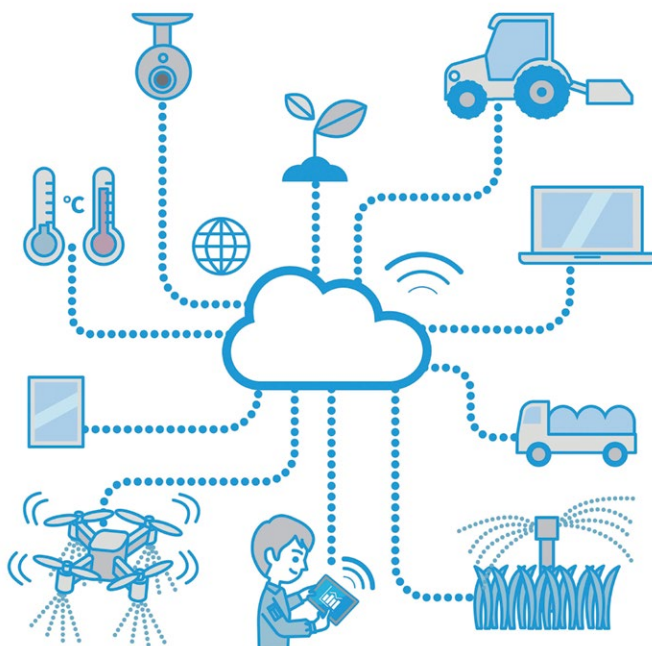

IoT refers to a system in which various things are connected via the Internet using sensors, software, networks, and other technologies to exchange information and cooperate with each other.

IoT has a wide range of applications, including smart homes, wearable devices, healthcare, smart cities, and agriculture. However, this guideline focuses on industrial IoT (IIoT), or IoT in manufacturing [5, 6, 7, 8, 9, 10, 11].

Figure 1 shows how a typical IoT system works. The blue area at the bottom represents the interior of a factory. Various devices that make up the IoT are placed there.

Intelligent devices and non-intelligent devices are placed in the orange area at the bottom. Non-intelligent devices cannot send data externally, like a regular room thermometer. These non-intelligent devices can send data when combined with a microprocessor, meaning they become “intelligent.” Henceforth, we will refer to devices with this kind of data transmission capability as “IoT devices.”



These IoT devices send data to a server called a gateway via an IoT area network. An IoT area network is a relatively short-range network for connecting IoT devices in a factory using Wi-Fi, BLE (Bluetooth Low Energy), etc.

The gateway stores and processes data from IoT devices and sends the data to an IoT server as needed. In the figure, the gateway sends the data to an IoT server on the Internet through a wide area network. Depending on the form of implementation, the IoT device may send data directly to the IoT server without going through the gateway.

The IoT server analyzes the data sent to it and, in some cases, uses advanced technologies such as AI to control the entire IoT system.

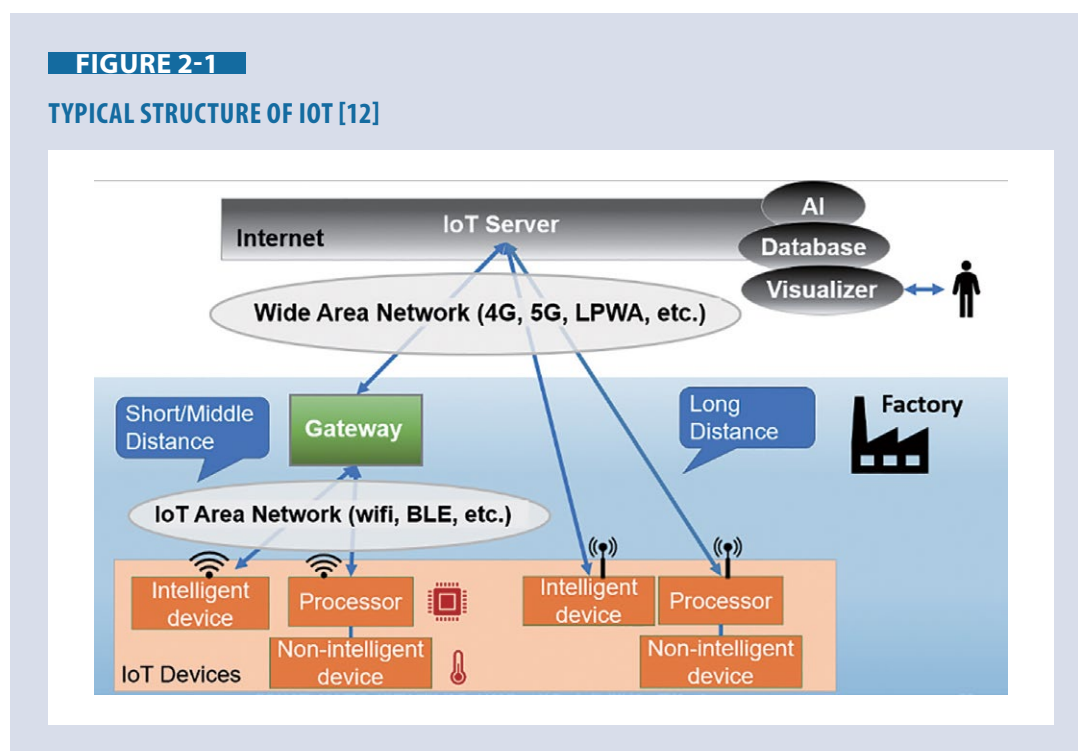

## Chapter 2.2 Bridging the Real World and Cyberspace

Now, let's look at IoT in terms of the real world and cyberspace

The left side of Figure 2 shows the real world, which consists of physical entities (objects). The real world is an analog world. The attributes of physical entities are not discrete digital but continuous analog, and we live in an analog world. To measure the analog attributes of physical entities, we need physical sensors. For example, measuring the temperature of air, a physical entity, with a resistance thermometer yields analog data in the form of resistance.

Converting this analog data to digital and transmitting it externally requires the help of a microprocessor. The converted digital data enters cyberspace on the right side of the diagram, which is an entirely digital world. In cyberspace, the gateways and IoT servers perform complex processing based on the obtained digital data.

The results processed in cyberspace are fed back to the real world, which moves actuators such as motors and cylinders to give some action to a physical entity, for example, a product on a production line.

In other words, IoT devices can perform mutual conversion between the analog real world and the digital cyberspace. Typically, a small portion of the information in the real world is reflected in cyberspace. Still, if this mutual conversion becomes more precise and real-time, a “digital twin” world will be realized, where the state of the real world is reproduced almost perfectly in cyberspace.

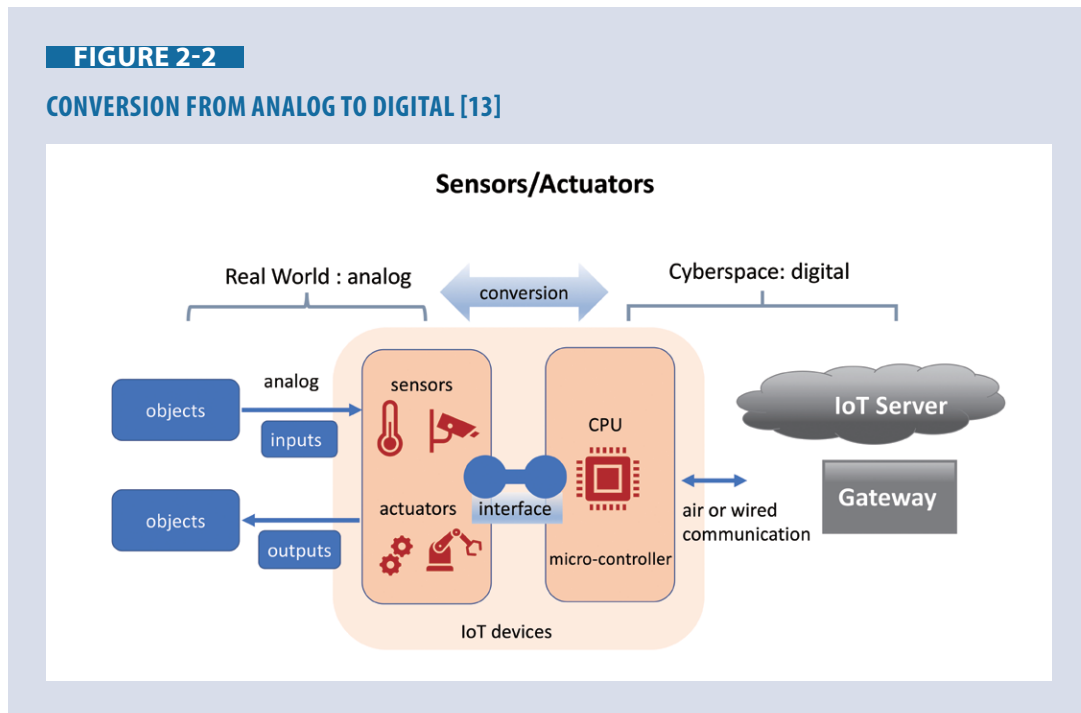

One issue here is interfacing an analog sensor with a microprocessor. Handling analog sensors requires knowledge of the physical characteristics of the sensors and electrical circuits, which is not easy to begin with. In recent years, however, sensors suitable for digitization and microcontrollers such as the Raspberry Pi with convenient interfaces have become available, making it possible to configure IoT devices easily and inexpensively. One of the reasons that the recent “do-it-yourself” trend known as the maker movement has become prevalent is that IoT devices have become easier to develop.

When we think of a digital twin, we tend to think of large-scale systems. Nonetheless, another major aspect of IoT is that you can start small digitization first with your own hands. That can be a great weapon for Digital Kaizen for small and medium-sized businesses.

### Chapter 2.3 Various Sensors Used in Factories

Various sensors are used in factories for different applications (Figure 3).

First, a sensor is needed to measure the condition of the production equipment.

An accelerometer detects acceleration to monitor a machine’s reciprocating motion. For example, by attaching an accelerometer to the moving parts of a press machine, it is possible to count the

machine's motion. Vibration sensors detect vibration and can be connected to motors to detect abnormal vibrations. The electric current sensor can be used for non-contact checking of excessive current flow in a circuit.

Temperature, humidity, and CO<sub>2</sub> sensors are used to monitor the condition of the work environment. CO<sub>2</sub> sensors, in particular, have recently come into common use to determine the need for ventilation. Other sensors, such as atmospheric pressure, illumination, noise, and dust, are also used depending on the characteristics of the work environment.

Monitoring conditions such as the increase or decrease of materials to improve productivity is also important. For this purpose, weight sensors, flow sensors that measure gas or liquid flow through the piping, etc., are used.

Infrared, laser, proximity, and distance sensors are also used to detect the position, passage, and presence of parts and the operator's position.

**FIGURE 2-3**

**VARIOUS SENSORS**

Use	Sensor
Monitoring Operation Status	Accelerometer Vibration Sensor Electric Current Sensor
Monitoring Work Environment	Temperature Sensor Humidity Sensor CO <sub>2</sub> Sensor Pressure Sensor Illumination sensor Noise Sensor Dust Sensor Magnetic Sensor
Measuring Materials or Parts	Weight Sensor Flow Sensor
Detecting Humans or Things	Infrared Sensor Laser Sensor Proximity Sensor Distance Sensor

Choosing the right sensor is very important. This is because sensors are the origin of all data. In addition, sensors are analog technology. To use them correctly, it is necessary to understand their operating principles and characteristics.

Below are some points to check when selecting a sensor.

**(1) Accuracy**

It is necessary to consider whether the sensor can measure with the accuracy required for the application. For example, the accuracy required for temperature control of chemicals differs from that required for measuring whether a room is hot.

**(2) Environment of use**

It is necessary to consider whether the sensor will be used in a normal indoor or outdoor environment or whether it may be used in a harsh environment.

**(3) Durability**

Usually, sensor accuracy deteriorates over time. It is necessary to know in advance how much degradation is acceptable and how long the sensor's life will be and to estimate the timing of replacement in advance.

**(4) Cost**

Normally, a single sensor is not very expensive. However, the cost may be higher if a high-speed, high-precision sensor or one with special specifications is required. Cost should also be considered when large quantities are likely to be used.

**(5) Power consumption**

IoT devices are often powered by batteries, making power consumption an issue. In many cases, a central processing unit (CPU) consumes much of the power. Still, the power consumption of sensors must also be calculated in advance.

**(6) Interface**

You need to consider how you will connect to the CPU. Consider whether it will be easy to connect or whether you will need to create a complex circuit on your own.

## Chapter 2.4 Microcontrollers Used in IoT

A computer is needed to acquire data from physical sensors, process it, and transmit it externally. A computer that combines a microprocessor and peripheral circuits in a compact package is called a microcontroller and is suitable for use embedded in other devices.

Many microcontrollers with high functionality, low cost, compactness, and low power consumption have recently become available. This has made the development of IoT devices much easier. Typical microcontrollers are shown in Figure 4.

The microcontroller called Raspberry Pi is particularly popular nowadays; you will learn more about Raspberry Pi in Chapter 4.1.

On the other hand, however, embedded applications often require something even smaller, less expensive, and less power-consuming, in which case a microcontroller that omits the operating system (OS) and has reduced hardware specifications is used.

Examples of such microcontrollers include the Arduino and Espressif's ESP32, which is compatible with the Arduino. Such controllers are designed so that when the CPU is in standby mode, it enters a mode called Sleep Mode, which consumes very little power.

On the other hand, if you want to integrate advanced AI functions and image processing into an IoT device or gateway, there are options such as NVIDIA's Jetson, although they are considerably more expensive.

**FIGURE 2-4****MICROCONTROLLERS USED IN IOT**

	Price	Language	Power Consumption	Manufacturer	OS
Raspberry Pi	\$80 (5 model b 8G)	Python	570mA, 22mA (sleep)	Raspberry Pi Foundation	Linux
Arduino	\$30 (Uno REV3)	C++	50mA, 0.57mA (deep sleep)	Arduino Holding	-
ESP32	\$10	C++	30mA, 5 $\mu$ A (deep sleep)	Espressif Systems	-



Raspberry Pi



Arduino



ESP32

**Chapter 2.5 IoT Wireless Area Network**

A relatively short-range wireless network that connects IoT devices within a factory is called an IoT wireless area network. Figure 5 shows typical examples.

**FIGURE 2-5****IOT WIRELESS AREA NETWORK**

	Typical Use	Distance (m)	Speed (bps)	Consumption Power
Wifi (IEEE802.11b)	Computer Network	100	11M	6W
Wifi (IEEE802.11ah)	Sensor Network	1000	4M	300mW
BLE (class 2)	Beacon	10	1M	10mW~500mW
ZigBee	Home Automation	30~100	20k~250k	~60mW
Wi-SUN	Smart Meter	1000~2000	50k~300k	1mW
Z-Wave	Home Automation	30	100k	23mA
Private LTE/Local 5G	Image Transmission	1000~10000	40M~10G	big

Wi-Fi is a communication method that everyone is familiar with, used even in homes. IEEE802.11b is used in most homes and factories among the various Wi-Fi standards. With a range of 100 meters and a transmission speed of 11 Mbps, IEEE802.11b is sufficient for videoconferencing and watching YouTube.

IEEE802.11ah makes configuring an IoT area network easy. Still, a new standard called IEEE802.11ah has been introduced for the IoT that extends the communication distance and reduces power

consumption. However, since sensor data is usually not very large, data transmission speeds are kept low at around 4 Mbps. Although not many products are compatible with this standard yet, it is expected to be widely used in the near future.

Bluetooth is used to interface with smartphones and PC peripherals, and the BLE standard, a low-power consumption version of Bluetooth, is suitable for the IoT. BLE also has a beacon function, which can detect the location of products and people in a factory.

Standards such as ZigBee, Wi-SUN, and Z-Wave are designed to intermittently transmit small amounts of data, thus saving even less power and reducing speed. They are used for applications such as smart metering and home automation. However, the transmission speed is slow, and large amounts of data, such as video, cannot be transmitted.

On the other hand, mobile technologies such as LTE/5G may be used when long-distance, high-capacity transmission is required. Examples of those applications include remote control of power shovels in ore mines. Because of its cost, its use by small businesses may be limited.

### Chapter 2.6 LPWA (Low-Power Wide-Area)

One communication method for connecting to a base station more than a few kilometers away from an IoT device is to use mobile networks such as LTE or 5G. However, mobile networks generally consume a large amount of power, and the communication speed is too fast to transmit sensor data, resulting in an over-specification problem. In contrast, a communication method, LPWA, more suitable for IoT, has been developed.

LPWA has the following four major features

- (1) Long battery life due to low power consumption
- (2) Communication speed is slow
- (3) Long transmission distance
- (4) Low cost

Figure 6 shows five well-known LPWA communication schemes.

**FIGURE 2-6**  
**LPWA POPULAR STANDARDS**

	Distance	Speed
SigFox	30~50km	100bsp
LoRaWAN	15km	300~100kbps
ELTRES	100km	80bps
NB-IoT	20km	62kbps
Zeta	2~10km	600bps

The details of each communication method are omitted, but note that the communication distance is indicated in kilometers and the communication speed in bits per second or kilobits per second.

Figure 7 plots the networks described so far, with the axes of communication distance and communication speed.

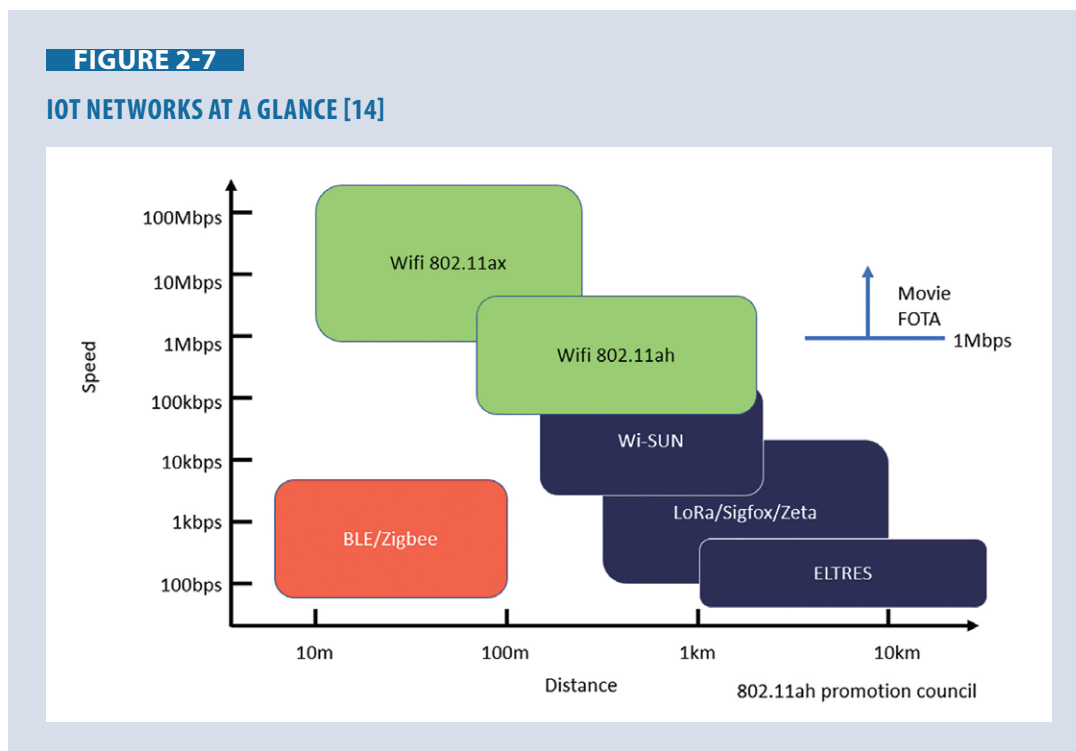

As a rough guideline for network selection, Wi-Fi would be a candidate if high-speed transmission (video or FOTA) or medium-range networking is required, LPWA if long distance but low speed is acceptable, and BLE if very short distance communication (e.g., home networking) is adequate.

## Chapter 2.7 Cloud Computing and IoT Platforms

Now, let us consider the role of the IoT platform.

There are many functions that an IoT platform provides. These functions are often too complex or advanced for the average engineer to develop on their own. Therefore, utilizing IoT platforms available as cloud services is generally effective.

Let's look at these functions next.

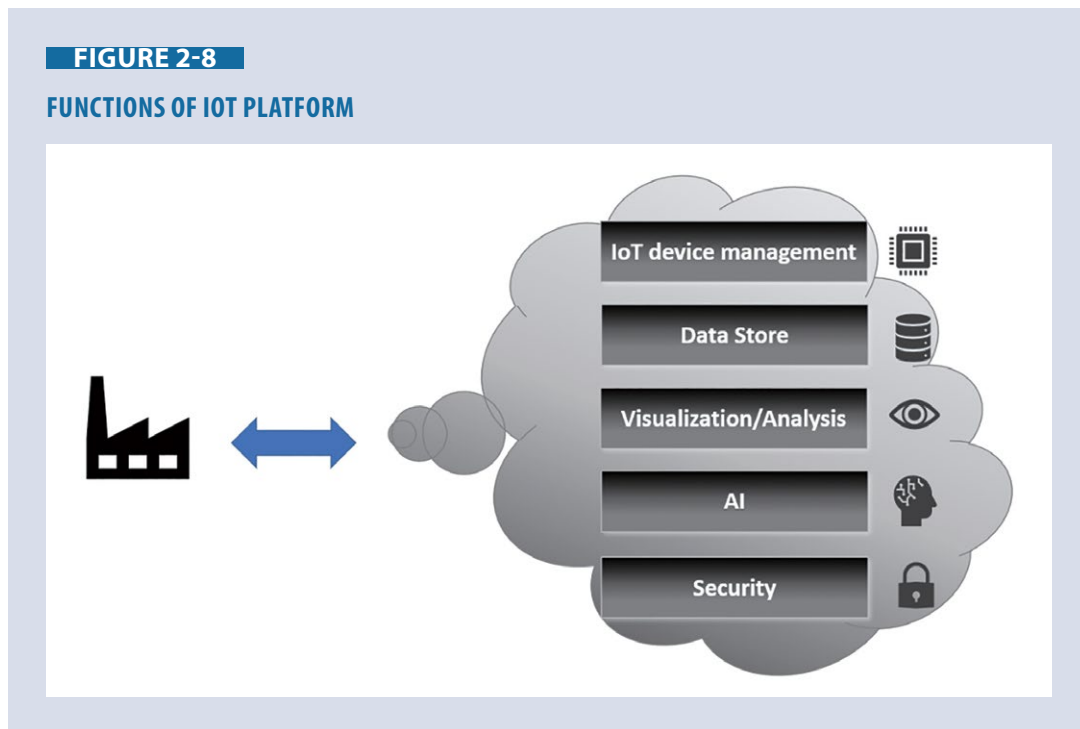

First, IoT platforms provide management services for many IoT devices.

As the number of IoT devices increases, the management effort increases and gradually becomes unmanageable. In such cases, the management services provided by IoT platforms can make management more efficient. Specifically, IoT platforms provide functions such as assigning device IDs, creating keys, enabling/disabling devices, remembering device locations, and updating device firmware.

Second, IoT platforms offer various types of data stores, allowing users to choose the best one for their needs. Most IoT platforms offer SQL databases, new types of databases called NoSQL, and databases suitable for storing time series.

Third, it provides a convenient means of visualizing data. Data can be represented in a variety of graphs, and multiple graphs can be combined into a dashboard. When data can be easily visualized and shared, everyone involved can easily understand what is happening in the system.

Fourth is the provision of AI capabilities. AI is developing rapidly and has become a powerful tool for improving productivity. However, creating data processing structures such as neural networks is not easy and impractical. By leveraging the AI capabilities of an IoT platform, you can more easily develop your own AI system.

Finally, ensuring the system's security is a very important and difficult issue.

If you try to do it by yourself, you may end up creating security holes, which is dangerous. Using the security features the IoT platform provides and following its best practices will be a practical solution.



## Chapter 2.8 AWS, Azure, Google Cloud Platform

There are three major cloud platforms in the cloud computing market. They are Amazon Web Services, Microsoft Azure, and Google Cloud Platform.

These cloud platforms offer a wide range of services, including not only manufacturing but also business analysis, marketing, advertising, and monitoring. First, we will look at these three platforms offering these services, not just IoT-specific features.

Figure 9 shows the global market share of these cloud platforms and how it has changed over time.

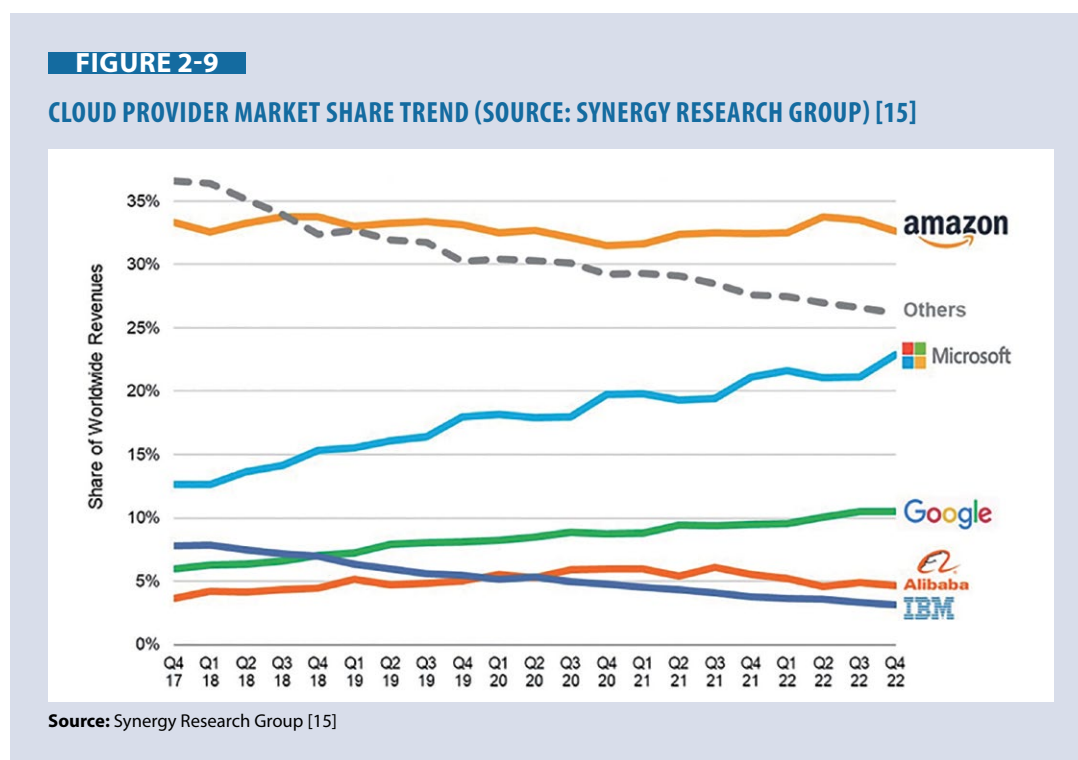

Amazon AWS maintains the top market share despite ups and downs. In contrast, Microsoft Azure is steadily increasing its market share. Google, on the other hand, seems to be struggling to gain market share, although it is growing.

Other providers appear to remain sluggish or lose their edge in this highly competitive market. Therefore, the following sections will focus on these top three providers.

Now, comparing these three companies is not an easy task. Generally speaking, AWS has the longest history and widest range of services. AWS seems to be a safe choice unless you have some particular preference.

Azure, with its growing market share, is another promising option. There are several reasons for this. First, it has a wide range of services that rival AWS. The functionality needed to build an IoT system can be found in both AWS and Azure. Also worth mentioning is that Azure is integrated with OpenAI, which allows you to use advanced AI. While Google has traditionally been considered superior regarding AI support, Azure is also gaining in reputation at this time (as of 2023).

Google Cloud Platform (GCP) seems to be a bit behind the other two in terms of breadth of services. Nevertheless, it has traditionally been considered strong in AI and image processing and may have strengths in specific applications.

In addition, Google has always had an outstanding strength in web advertising systems, and one of its strengths is that GCP can be linked to excellent services such as Google Analytics, a website access analysis service.

Next, we will look at these three platforms from an IoT perspective.

**FIGURE 2-10**  
**COMPARISON OF IOT PLATFORMS**



	AWS 	Azure 	GCP 
<b>IoT Device Management</b>	AWS IoT Core/AWS IoT Device Manager	Azure IoT Hub	Cloud IoT Core
<b>Data Store</b>	Amazon DynamoDB	Azure Cosmos DB	Firebase Realtime Database
<b>Visualization /Analysis</b>	Kibana	Power BI	Looker Studio
<b>AI</b>	Amazon SageMaker /Amazon Recognition	Azure Machine Learning/Computer Vision	Vertex AI/Vision AI
<b>Security</b>	AWS IoT Device Defender	Defender for IoT	(Cloud IoT Core)

Figure 10 extracts functions related to IoT system construction from the many features of the three platforms.

When it comes to IoT device management, all three of these have their capabilities. With these capabilities, you can efficiently perform tedious management tasks such as registering, provisioning, connecting, monitoring, and updating devices.

Firmware-over-the-air (FOTA) technology, which remotely updates IoT device programs, is also available through these cloud platforms.

In terms of data stores, all three platforms have traditional relational databases. In addition, they also have a type of database that can be classified as a key-value database. Since key-value databases are suitable for storing time-series data from IoT devices, they are more efficient than relational databases.

Visualization is another major theme of IoT systems. How quickly you can create attractive dashboards is a significant point. All three platforms have useful visualization services. We will discuss that later.

The AI field is one of the most competitive and rapidly changing. New AI-related services are appearing one after another. Especially since the emergence of generative AI, such as ChatGPT and Midjourney, all these platforms have been trying to incorporate new AI features. If a particular AI service is effective for your company's Digital Kaizen, it will be a major factor in choosing a cloud platform. AI in manufacturing will be discussed further later in Chapter 2.13.

On the security side, AWS and Azure offer a feature called Device Defender, which closely monitors and analyzes the behavior of each device and automatically detects security threats. Google does not currently have an equivalent feature. Still, the security features included in Google Cloud IoT Core are likely to be sufficient in many cases.

Which of these platforms to choose when building an IoT system is a difficult question. It is possible to combine multiple services to suit your needs. Most services are pay-as-you-go, so trying different services and proceeding gradually is important.

## Chapter 2.9 How to Store Data

Many IoT devices incessantly send time-series data to IoT servers. Even though it is a collection of short text data such as JSON, the required space can quickly become gigabytes or terabytes. Where should such data be stored?

Figure 11 shows data storage candidates.

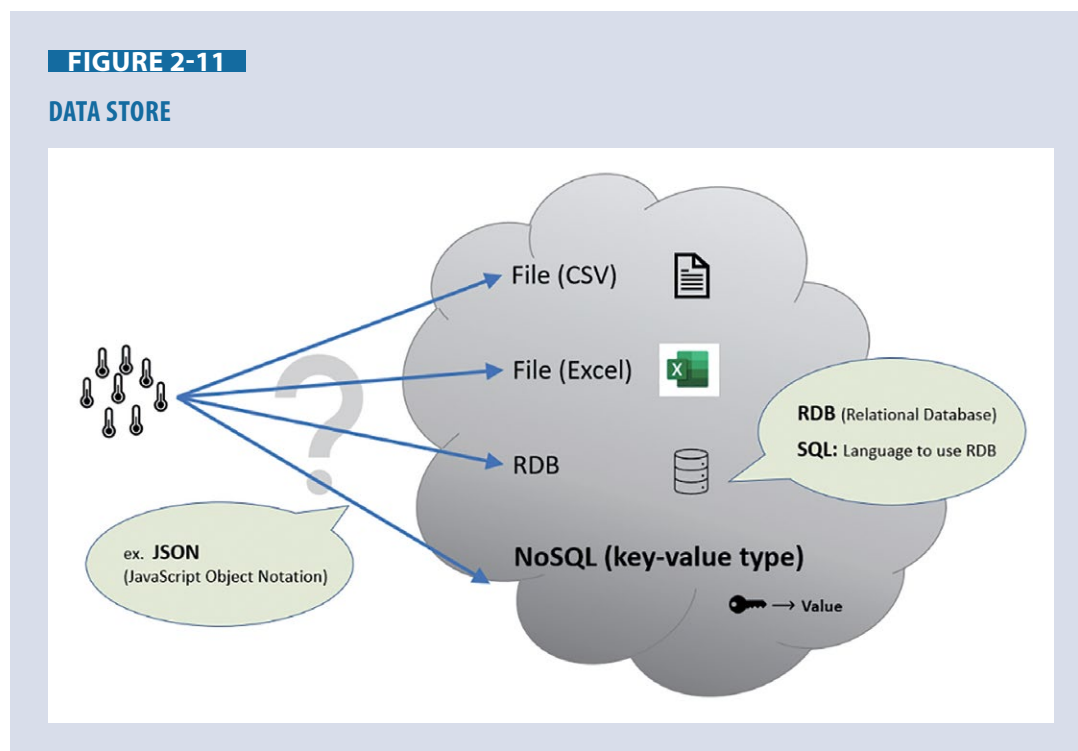

You might think of saving your data to a comma-separated-values (CSV), Excel, or Google spreadsheet for now. These methods are very convenient when the data is small. You can open an editor such as Notepad and easily view the file. However, the larger the data, the more difficult it becomes to handle. Adding, updating, selecting, and viewing large data files is very difficult.

One solution is to store the data in a relational database (RDB). RDBs have a long history and are already an established technology. For example, RDBs are indispensable for developing robust systems that require strictness and consistency, such as bank account management systems.

Then, there is a special language called SQL for manipulating RDBs. With SQL, data can be created, deleted, and updated efficiently.

However, there are still problems. Because of the strict and complex logical structure of RDBs, the larger the data, the slower the processing speed. In addition, the data are so closely interrelated that splitting them into multiple databases is almost impossible.

Now, let's consider the IoT data we are focusing on. Once data from sensors is stored, it is rarely updated. Also, the relationships between data are usually not as complex as in banking systems. Therefore, data should be more easily partitioned.

Key-value databases were invented to store and retrieve data with these characteristics. Databases that do not use conventional SQL, such as key-value databases, are called NoSQL (not only SQL).

The following briefly explains the differences between RDBs and key-value databases.

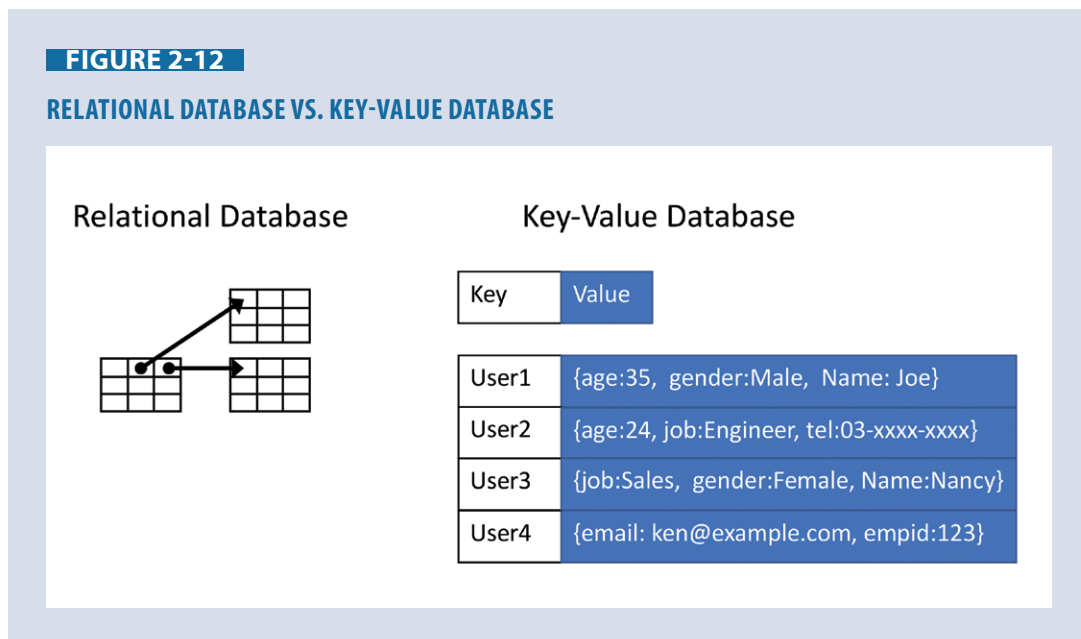

First, let's review the traditional database, RDB. Data in an RDB is represented by tables, also called entities. These tables are structured so that there is no redundancy in the data. In addition, the relationships between tables are strictly defined. Data is extracted, deleted, and updated using a special language called SQL.

The most well-known RDB management systems include Postgres SQL, My SQL, SQL Server, and Oracle. You can install these RDBs on your computer or use them as cloud services provided by platforms such as AWS or Azure.

Key-value databases, on the other hand, as the name suggests, consist of keys and values. As a result, data can be easily divided into multiple databases, making them highly scalable. In this example, values are represented in JSON format. The notation is simple, easy to understand, and intuitive in this format.

There are many key-value databases available. The best-known stand-alone systems include Mongo DB, Apache Cassandra, Redis, and InfluxDB. Most of them are open source and can be downloaded from the Internet and installed freely on your computer. They are also available as cloud services.

The three major cloud service providers also offer key-value databases. They are Amazon DynamoDB, Azure Cosmos DB, and Google Firebase Real-time Database. These databases are easy to use, fast, scalable, and economical. When building IoT systems, these databases can be used to increase development and operational efficiency.

## Chapter 2.10 Data Visualization

Next, consider data visualization and sharing.

Data visualization and sharing are very important. Three basic benefits of this are listed below.

(1) Grasping the whole picture

When humans look at data consisting only of numbers, they can only understand a small portion of it, and it will be difficult to determine what is happening there. The entire picture can be grasped only by visualizing the data using appropriate graphs.

(2) Human insight comes into play.

No matter how smart AI is, it cannot outperform humans in terms of insight to find hidden problems and intuitively derive solutions. This is because AI sees only data, while humans see the real world. Visualization and sharing of data bring out human insight.

(3) Promoting team spirit

By sharing the same data equally among team members anytime, anywhere, each member's sense of ownership is heightened, and team spirit is strengthened. This will further lead to increased creativity in the organization.

A dashboard is a single screen that represents data in a variety of graphs. Figure 13 shows an example of a dashboard.

**FIGURE 2-13**

**DASHBOARD**

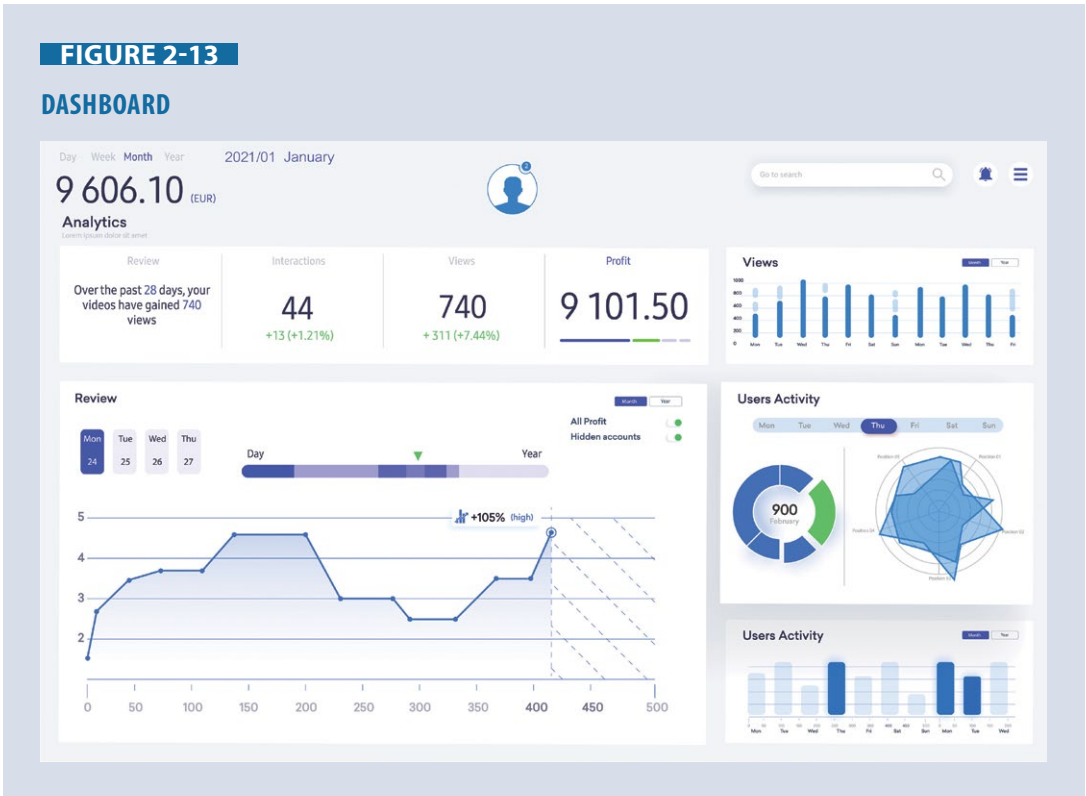

In this dashboard, the various types of graphs are organized and neatly laid out. The beautiful design is also a major factor in its human appeal.

The problem lies in creating such a beautiful dashboard quickly and inexpensively. We usually cannot afford to hire a graphic designer.

Fortunately, there is a solution. In recent years, many software and cloud services have been released to support data visualization. (Figure 14) By taking advantage of these, even non-designers can easily create attractive dashboards.

**FIGURE 2-14**

**VISUALIZATION TOOLS**

BI Tool	Characteristics
Grafana	Suitable for Time Series
Microsoft Power BI	Low Price, Mobile Support
Kibana	OSS*, Amazon Elasticsearch
Google Looker Studio	Various Data Sources, User Friendly
Tableau	High Spec, Expensive

\*OSS: Open-Source Software

Microsoft Power BI is probably the most popular of its kind. It is easily connectable to Microsoft Azure but can also accept a variety of data sources from other platforms, such as AWS and GCP.

Kibana is often used as a visualization system for AWS. Kibana is particularly compatible with Elasticsearch and can be easily connected.

Google also offers Looker Studio, a versatile visualization tool.

Tableau is well-known outside of these major platforms for its long history. It is high-spec but relatively expensive. Grafana specializes in time series visualization and is another popular IoT visualization tool.

Selecting the right visualization tools is one factor contributing to a successful IoT project.

## Chapter 2.11 Sending Alerts

The IoT server should periodically notify personnel of the current status of the line and immediately alert them of any abnormalities that may have occurred.

In such a case, the IoT server must immediately tell management what happened in the factory to prevent damage to equipment and personnel and loss of productivity.

Nowadays, everyone carries a smartphone and constantly uses communication tools such as e-mail and various social networking services. IoT servers can also use these communication tools to send messages.

For example, an IoT server can send notifications to a smartphone app, send an e-mail, post to Facebook, or send a message to Slack. Specifically, AWS Simple Notification Service, Azure Notification Hub, and Google Cloud Monitoring.

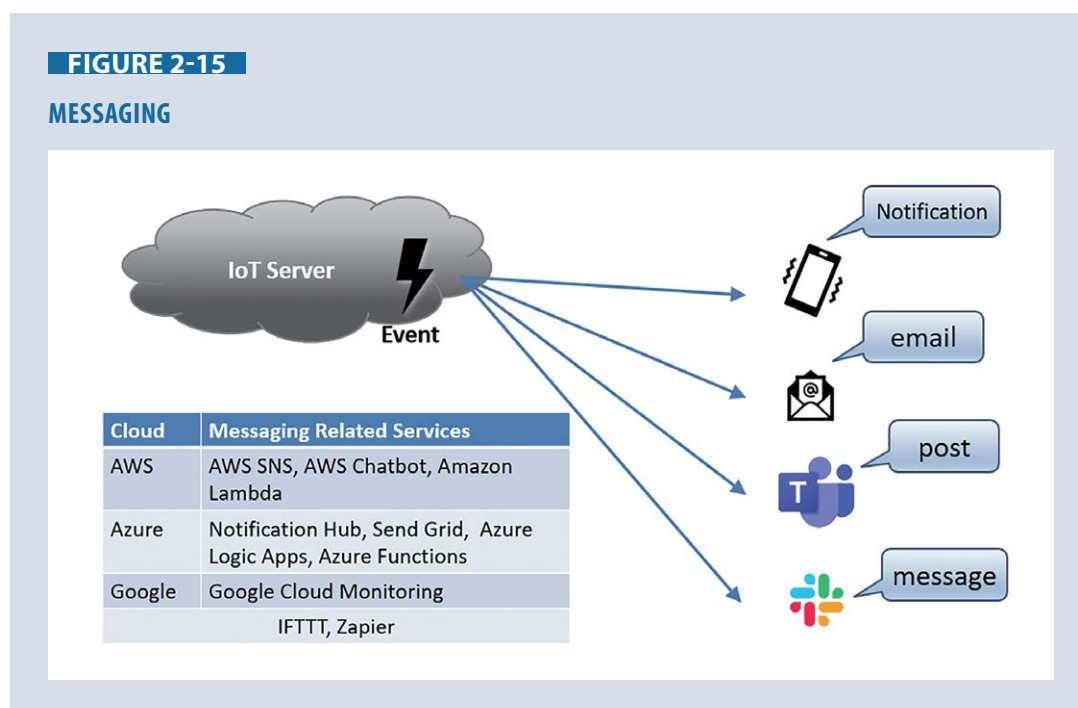

In addition to these cloud platforms, some other services called integration platform as a service (iPaaS) have emerged in recent years. IFTTT [16] and Zapier [17] are among them. These services can send messages to almost any cloud service that exposes its API with no code, simplifying the messaging process.

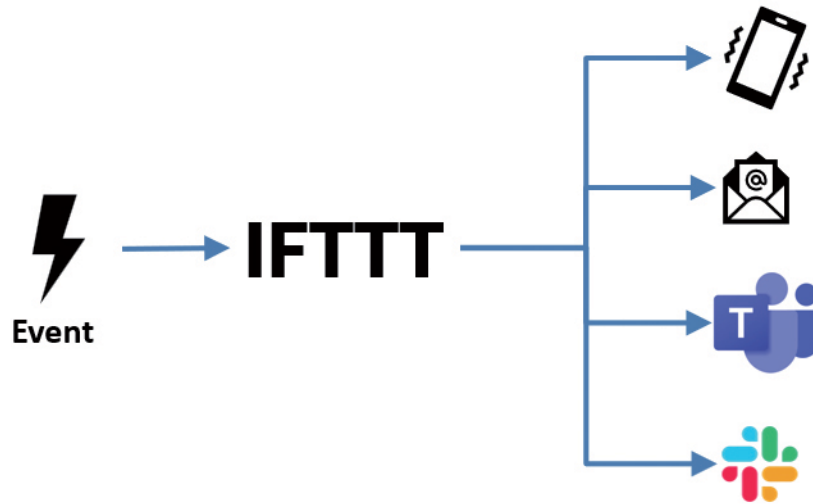

## Chapter 2.12 Programming

### 2.12.1 Programming of IoT devices

Programming is one major challenge when building an IoT system. IoT systems require programming in multiple places.

**FIGURE 2-16**  
PROGRAMMING FOR IOT SYSTEMS

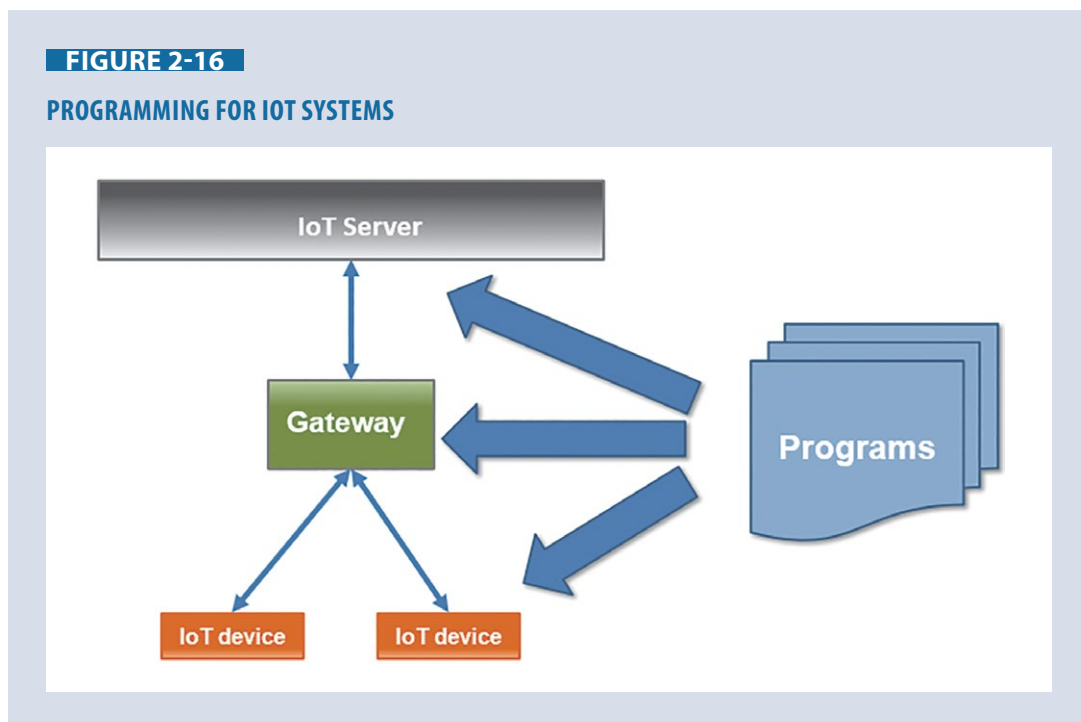



First, a microcontroller such as the Raspberry Pi or Arduino is used to measure sensor values, connect to the server, send data, and handle errors. Programming is required for this.

Second, the gateway needs a program that collects data, organizes it, sends it to a cloud service, and returns feedback to the IoT device.

Third, you need to create a program that runs on an IoT server to perform very complex tasks such as managing devices, storing data, analyzing data, and communicating with people.

The problem is that these are three completely different computer systems. Usually, you cannot write programs using the same language and the same environment.

For example, you might have to use C++ for an IoT device, Python for a gateway, and Java for an IoT server. And each language requires a language-specific programming environment that you need to learn separately.

### 2.12.2 Language Characteristics

Let's look at the characteristics of some programming languages used in the IoT. There are many programming languages used in IoT. These are C++, Python, Java, and JavaScript. Each of these languages has its own strengths and weaknesses.

The executable code is compact and fast, maximizing the performance of the hardware. However, it is said to be difficult to learn due to its difficult syntax.

Python is a new language released in the 1990s and is said to be easy to learn, even for beginners. It has many AI-related libraries and is currently very popular. However, because it is an interpreter, it is not very fast. Python is often used in the Raspberry Pi but is uncommon in Arduino and ESP32, which have lower hardware specifications. You will learn more about Python in 3.1.8.

Java has the feature of having a strict object-oriented syntax and running on any OS. It can be used on the Raspberry Pi with Linux but is not so common on Arduino or ESP32.

While JavaScript began to be used to program browser-based applications, it has recently been used for other purposes. For example, Google Application Script, which allows programming Google services, uses JavaScript as its language. It is also possible to program Arduino and ESP32 in JavaScript.

### 2.12.3 Integrated Development Environment (IDE)

However, it is not only the language that determines programming productivity. The choice of development tools is another major factor affecting productivity.

Program development involves not only writing source code but also editing, debugging, compiling, linking, loading, testing, version control, and many other tasks.

IDEs, or integrated development environments, provide an environment where these cumbersome functions can be used seamlessly in a single application. In other words, everything you need for programming is integrated into a single application.

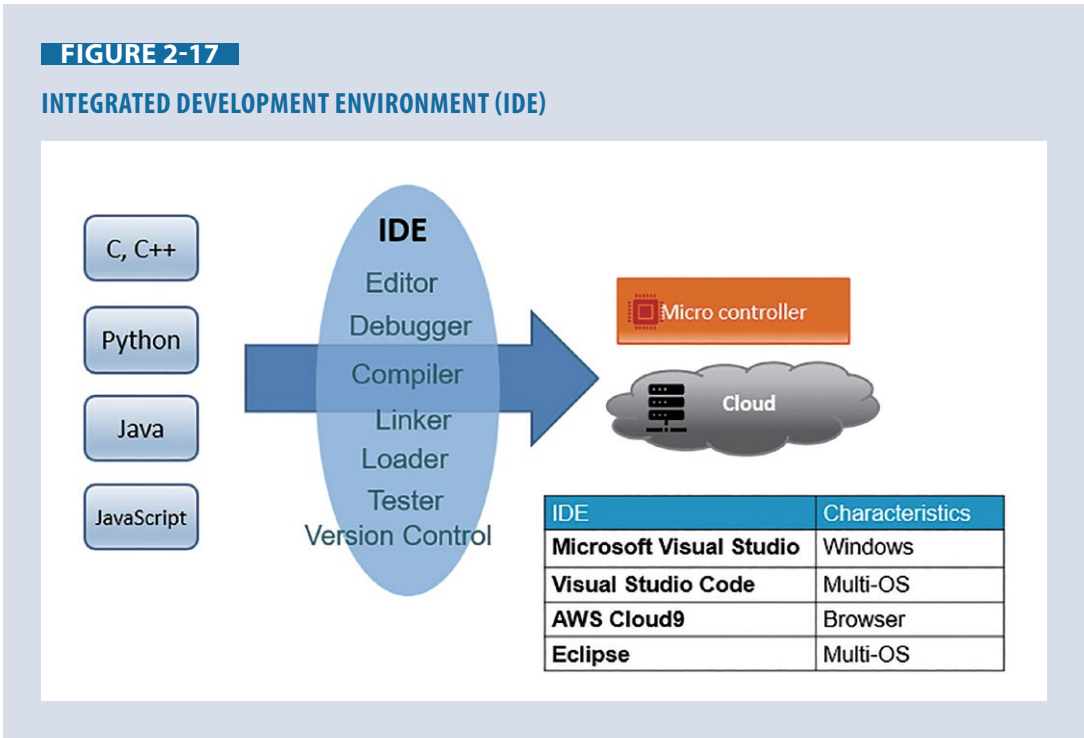

Some commonly used IDEs are shown in the lower right corner of Figure 17.

Microsoft Visual Studio has a long history and is the most highly regarded IDE on the market. It is the IDE of choice for developing applications, especially for Windows.

A new version of Microsoft Visual Studio, called Visual Studio Code, has recently been released. Compared to Visual Studio, the functionalities of Visual Studio Code are limited to editing and debugging. However, the biggest advantage is that it is cross-platform and runs on Linux on the Raspberry Pi.

They are both notable for their productivity. Microsoft Visual Studio and Visual Studio Code have a great autocomplete feature called IntelliSense. Furthermore, an AI feature called Copilot has become available, making them even more productive IDEs. In Section 4 of this guideline, we use Visual Studio Code.

Developed by Amazon, AWS Cloud9 is available in many languages, comparable to Visual Studio. Surprisingly, it runs in the browser and can be used with Chrome, Edge, Firefox, Safari, and other browsers regardless of operating system.

The most famous open-source IDE is Eclipse, which is used mainly by the Java community. By installing plug-ins, you can use Eclipse to develop various applications such as mobile apps, Python projects, Arduino projects, etc.

Some IDEs are specialized for specific hardware. For example, the Arduino IDE is an IDE specialized for Arduino. It can also be used with ESP32, which is compatible with Arduino. You can also build an Arduino environment with Eclipse. However, if your main focus is Arduino hardware, such specialized IDEs may be more suitable.

The choice of IDE affects productivity. If you do not have a specific preference, it is best to choose one that is as popular as possible and has the most information available on the Internet.

### 2.12.4 Using GitHub

Git and GitHub [18] have become indispensable for anyone involved in software development. There is a reason why they are so popular.

First of all, Git is one of the major version control systems. When you write a document, be it a computer program or a Word document, you create many versions. In doing so, you may be tempted to put version numbers or dates in the file names, but this will cause many more files to be created, and it will be difficult to know what you have fixed.

A version control system takes care of the complexity of such version control. It allows you to return to an older version whenever you want without losing consistency.

On the other hand, GitHub is a Git-based web service that allows you to register with GitHub and let it handle most of the work of managing your program files.

Version control systems are also very important when working in a team. If each member edits a single file as they like, chaos will happen. Using a version control system avoids this confusion, increases productivity, and leads to the project's success.

Another point worth mentioning is that GitHub allows programs to be shared among the software community. Programs can even be shared across company boundaries.

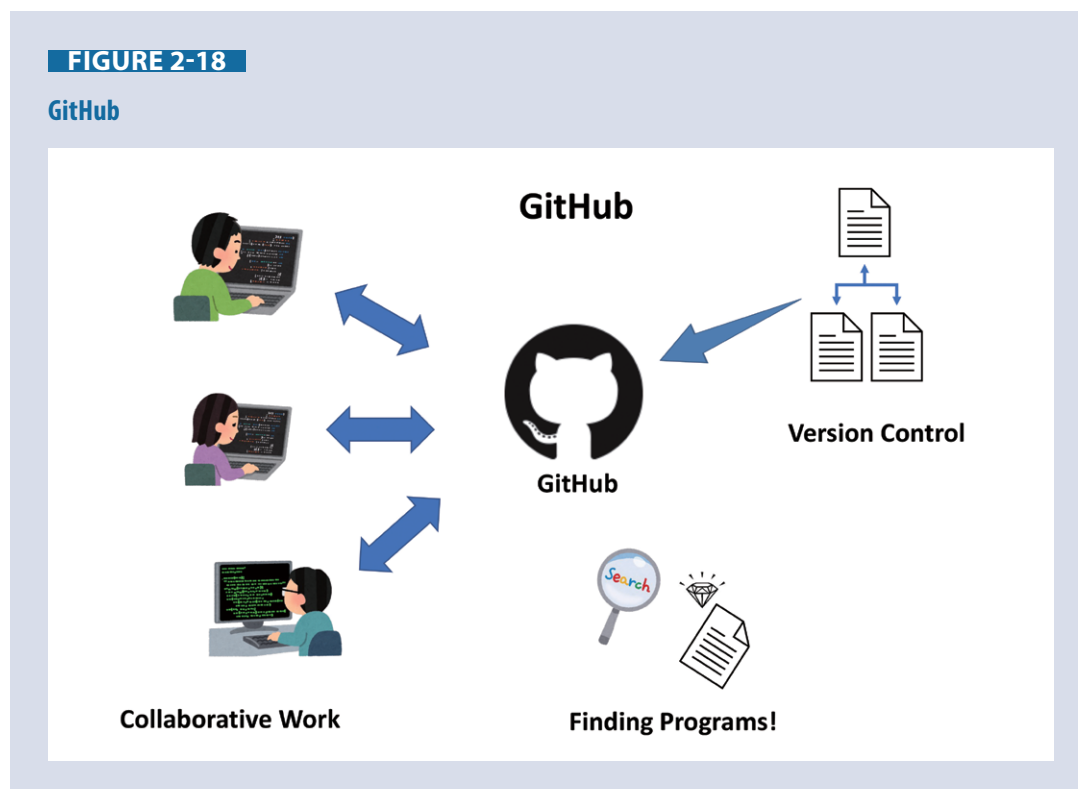

Search GitHub, and you may find open-source projects similar to your project or useful libraries. This can greatly increase your productivity using programs already tested without writing your own from scratch.

GitHub is so useful that many IDEs, such as Visual Studio and Eclipse described previously, seamlessly integrate GitHub into their programming environment. Therefore, if you use these IDEs, you will naturally be able to use GitHub.

#### 2.12.5 No Code/Low Code

Computer programming has been said to be difficult to learn and unproductive. Therefore, various techniques have been developed to increase productivity. One such technique is “low-code/no-code,” in which the amount of code is reduced, or nothing is written.

GUI development has often been done by dragging and dropping already-made components such as buttons and list boxes. However, few tools were available to create a programming flow.

In recent years, however, tools have been developed that allow users to write flows by placing and connecting visual components without writing text code.

One of the most famous is SCRATCH [19], which the MIT Media Lab developed for children. It is an excellent system, but since it is educational, a more practical Node-Red [20] can be used for IoT projects.

Figure 19 shows the Node-Red editing screen. You can create a flow by selecting components, called nodes, in the left frame and dropping them into the right frame. Then, wires connecting them are placed, and their order is defined. However, the specific processing must be written in JavaScript.

The advantage of Node-Red is that it provides many nodes for IoT development, including data collection, device control, server connectivity, database connectivity, data processing, and user interface. You can also create cool dashboards. In fact, many practical IoT projects using Node-Red are reportedly underway worldwide.

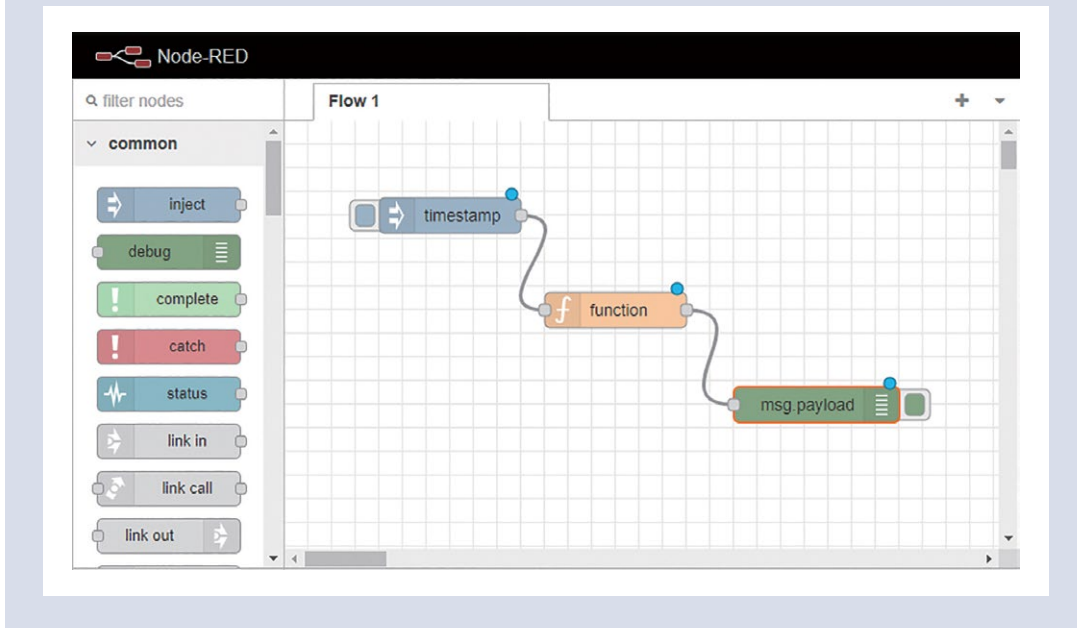
**FIGURE 2-19****NODE-RED**

However, you must be careful with the size and complexity of the project. The larger the system, the more the limitations of these tools will surface and may spiral out of control.

You should first try to conduct a small test project to see if that technology is right for your project. You should not jump into full-scale development quickly.

Below is a summary of the main advantages and disadvantages of no-code/low-code tools.

**Benefits:**

- No or less programming expertise  
Programming is done by combining visual elements or selecting items from a menu, so there is no need to study language syntax. Non-experts can use that technology.
- Quick development  
Because it combines elements, it can be programmed quickly and easily adapts to changing requirements.
- Less prone to errors and bugs  
Because it combines elements that have already been debugged, it is less prone to errors and bugs.

**Disadvantages:**

Not suitable for large-scale development

- Combining visual elements cannot handle the complexity as the project grows in size and complexity.

- Low degree of freedom and scalability  
Especially with no code, you can only use the prepared functions and may not be able to add the functions you need.
- Possible vendor lock-in  
Dependence on a specific vendor’s platform makes it difficult to migrate to other platforms in the future.

### Chapter 2.13 AI in Manufacturing

AI is undoubtedly one of the driving forces behind Digital Kaizen.

AI is advancing rapidly, and examples of its application in factories are increasing. Knowledge of AI technology is essential for Digital Kaizen. AI in the manufacturing industry is explained below.

There are many different types of data that can be utilized in a company. In day-to-day business transactions, these include sales, inventory, and order information. On the production line, there is real-time machine operating data. The quality control department has data on normal and abnormal products. In the delivery field, a wide variety of data such as where delivery trucks are running or waiting. The text documents written by employees on a daily basis are also important data, and these amount to an enormous amount of data.

All of these data can be subject to AI processing. So, what exactly can we expect?

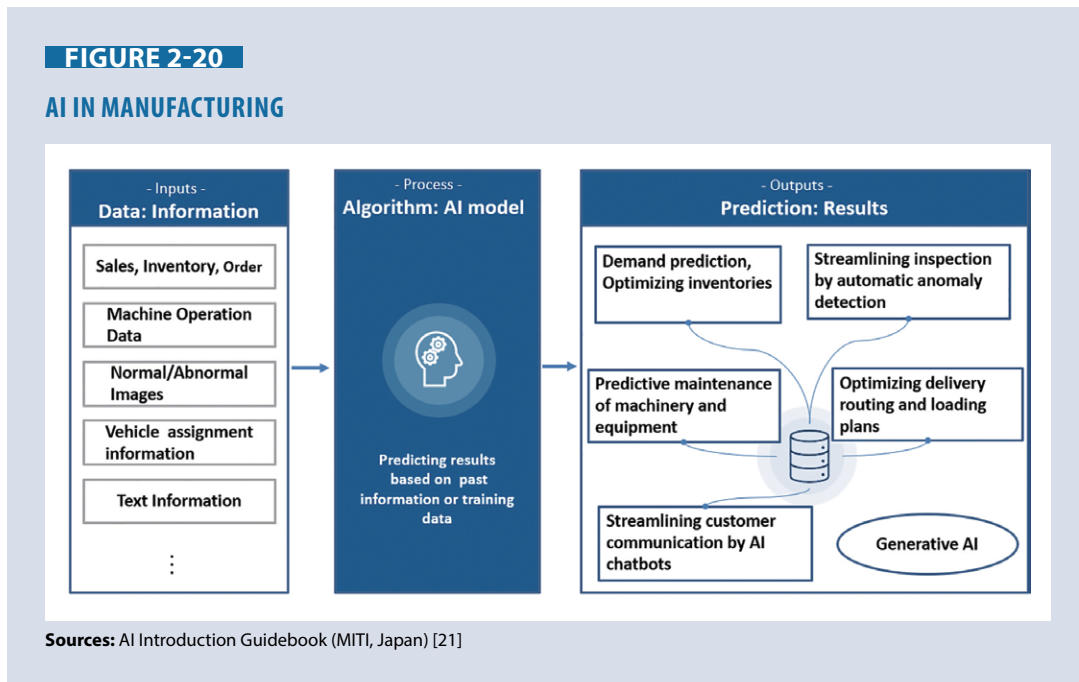

The following are five areas where AI can be expected to produce concrete results.

**(1) Demand forecasting and inventory optimization**

Since AI can process vast amounts of data, including not only past actual demand but also unstructured data such as social media chatter, news articles, and weather forecasts, it is

expected to be able to forecast demand more accurately. This also leads to inventory optimization.

**(2) Predictive maintenance of machinery and equipment**

By processing and learning a large amount of information from sensors attached to machinery and equipment, it is possible to predict failures and perform maintenance before they cause a shutdown. This enables more efficient and low-cost maintenance than either after-the-fact maintenance (to deal with breakdowns as they occur) or preventive maintenance (to perform maintenance on a regular basis).

**(3) Streamlining inspections through automatic defect detection**

By having AI learn data on good and defective products, AI will be able to identify good and defective products. This can streamline the inspection process. Unlike conventional pattern recognition, it also has the advantage of determining defects without defining characteristic values for non-defective products.

**(4) Optimizing delivery routes and cargo handling plans**

Collecting and learning data on road networks, delivery points, traffic conditions, and other relevant factors (weather, road closures, delivery time zones, etc.) can yield efficient delivery routes.

**(5) Streamlining customer communication with chatbots**

Customer communication is one of the biggest challenges in the manufacturing industry. Chatbots allow you to answer inquiries, help troubleshoot problems, make suggestions, and even book something.

Generative AI, a hot topic recently, is also expected to significantly benefit product design, manufacturing processes, and software development. AI is advancing very quickly, and it is important to stay interested and aware of trends to see how the manufacturing industry can take advantage of this.

## Chapter 2.14 Machine Vision

In this chapter, we would like to introduce machine vision as an advanced technology for readers who understand the basics of IoT.

Machine vision has emerged as a pivotal technology in enhancing production efficiency, quality, and manufacturing optimization. With the integration of artificial intelligence, it is gaining importance in smart manufacturing and Industry 4.0.

Combined with IoT sensors and real-time data analysis, machine vision can be a powerful tool for predictive maintenance, checking product appearance, and detecting defective parts. [22]

**The following pictures** (Figure 21) show some typical tasks machine vision can achieve. These object identifying abilities combined with other traditional techniques will lead to kaizen in manufacturing factories.

**FIGURE 2-21**  
**MAJOR TASKS OF MACHINE VISION**

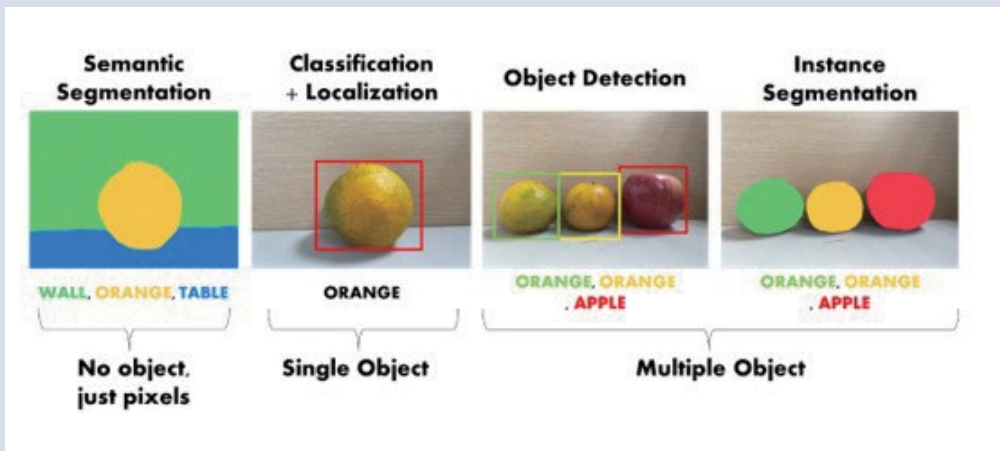

#### 2.14.1 Traditional Machine Vision and the Rise of AI

Before AI and machine learning, machines already had “vision” capabilities using algorithms developed in the early 1970s. This traditional machine vision technology can be used to detect parts and defects in a factory.

It works well for simple tasks like reading barcodes or recognizing standard shapes. Still, it struggles with complex things like reading handwriting or identifying wrinkled labels. Despite its limitations, this technology greatly improved manufacturing by doing jobs faster and more accurately than humans [23].

The rise of AI is fueled by big data, enhanced computing capabilities, and deep learning advancements, leading to increased commercial interest and research investment. AI’s application in computer vision, utilizing neural network models, allows for detecting minute discrepancies in images, improving the identification of defects in materials and electronic components.

Data scientists build specific neural network models for specific applications, known as supervised training. The computer reviews thousands of samples and finds meaningful patterns, including patterns that humans may be unable to detect. Some models can detect dead pixels and discolored pixels on displays, check for gaps in solder joints, and precisely locate loose threads in the fabric.

#### 2.14.2 Machine Vision Image Preprocessing

Modern machine vision is a discipline that employs computer science and artificial intelligence technologies to enable machines to simulate and comprehend the human visual system.

In machine vision, there are four primary processes: image preprocessing, image segmentation, image analysis, and pattern recognition. The following sections will briefly explain these four technical terms [24]:



- 1. Image preprocessing:** Image preprocessing, a foundational aspect of image processing, modifies each pixel's grayscale intensity through point operations. Essential for success in later tasks, poor preprocessing can hinder overall performance.
- 2. Image segmentation:** Image segmentation separates objects and backgrounds as a key step before object recognition. It falls under mid-level image processing to extract or capture attributes from the input image.
- 3. Image analysis:** Image analysis reduces high-dimensional input images by focusing on important regions, decreasing computational load, and improving results. It examines image areas to extract feature values of these regions or objects.
- 4. Pattern recognition:** Following image analysis, the necessary feature values within the image are obtained. These image feature values and measured values undergo the pattern recognition process, transforming them into recognizable symbols.

In machine vision, image preprocessing is a crucial step for subsequent feature extraction and pattern recognition. Image preprocessing includes multiple stages, optimizing and enhancing the original visual data to make it more suitable for subsequent processing. These preprocessing steps help improve the model's performance, enabling more accurate classification, detection, or identification. Common methods related to image preprocessing include:

- 1. Image denoising:** Image denoising is a technique to eliminate or reduce unnecessary noise in images, enhancing the accuracy of subsequent image processing. Common denoising methods include [25]:
  - **Median filtering:** Median filtering removes noise by replacing each pixel's value with the median value of its surrounding pixels. This effectively eliminates prominent brightness anomalies such as bright and dark pixels.
  - **Mean filtering:** Mean filtering is often used to smooth images and reduce high-frequency noise. This method replaces each pixel's original value with the average value of its surrounding area, helping to eliminate sudden brightness changes and resulting in a smoother image.
- 2. Image smoothing:** Image smoothing is a technique to reduce local image variations, also known as image blurring. This process aims to reduce high-frequency noise, smooth out details, and make the image more processable. Smoothing operations typically use a filter to perform weighted averaging. Common smoothing methods include [26]:
  - **Gaussian blur:** Gaussian blur uses a Gaussian function to calculate the filter weights, replacing each pixel's value with a weighted average of its surrounding pixels. Compared to mean filtering, Gaussian blur places more emphasis on the central pixel and reduces the degree of smoothing at the edges, often effectively preserving image details.
  - **Bilateral filtering:** Bilateral filtering considers both spatial and color differences between pixels to preserve edge details in images. While traditional average filters blur the details in images, particularly at the edges, bilateral filters give higher weight to pixels that are spatially close and have similar colors.

**FIGURE 2-22**  
**COMPARISON OF THE ORIGINAL IMAGE WITH DIFFERENT PREPROCESSING RESULTS**

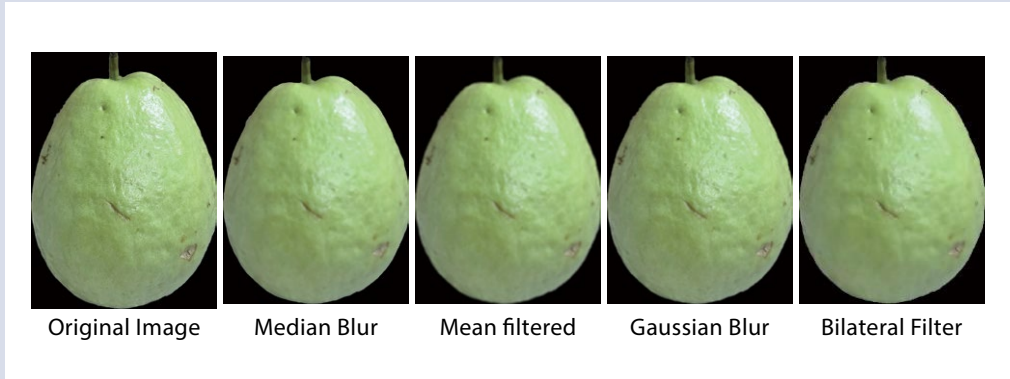

**3. Image sharpening:** Image sharpening enhances the edges and details in an image. Image sharpening typically accentuates the intensity changes between pixels, making the edges more distinct. This can improve the visual appeal of the image and object recognition. Common image sharpening methods include [27]:

- **Laplacian filter:** The Laplacian filter is a high-pass filter that enhances the changes in pixel values. Applying a Laplacian filter to an image can make the edges sharper [28].
- **Canny edge detection:** Canny edge detection is a classic and widely used image processing technique to detect image edges. Its primary goal is to identify changes in intensity in the image, which often represent the boundaries between objects.
- **Sobel operator:** The Sobel operator calculates image gradients primarily to identify areas of significant intensity change, i.e., edges. It is based on convolution operations, typically applied to grayscale images. This operator has horizontal and vertical components, using two convolution kernels to calculate the gradient.

**FIGURE 2-23**  
**SOBEL OPERATORS**

Horizontal Sobel Operator	Vertical Sobel Operator
$\begin{bmatrix} -1 & 0 & 1 \\ -2 & 0 & 2 \\ -1 & 0 & 1 \end{bmatrix}$	$\begin{bmatrix} -1 & -2 & -1 \\ 0 & 0 & 0 \\ 1 & 2 & 1 \end{bmatrix}$

For each pixel, the Sobel operator calculates the gradient in horizontal and vertical directions and then computes the gradient’s magnitude and direction.



Original Image



Laplacian Filter



Canny Edge Detection



Results of Horizontal and Vertical Gradients after Sobel Operation



Results of Gradient Magnitude and Gradient Direction after Sobel Operation

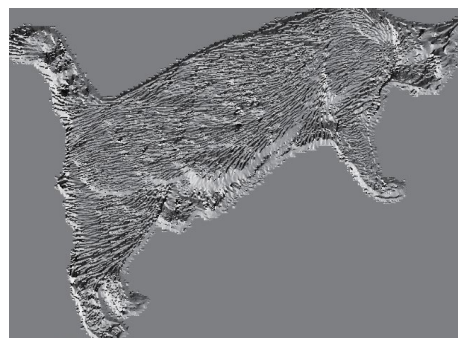

### 2.14.3 Neural Network

Neural networks are a data model inspired by the human brain's functioning, using interconnected nodes to process data similarly to neurons. They simulate how the brain responds to stimuli by transmitting signals through neural cells, enabling computers to learn and improve continuously through a mechanism called deep learning. This method allows for an adaptive system that learns from errors and enhances performance over time [29].

Neural networks are structured with an input layer for data entry, hidden layers for processing, and an output layer for results, being linked by weights. Data moves from the input across layers, with the network adjusting weights to improve predictions when errors occur. This learning process repeats until achieving sufficient accuracy, enhancing the network's predictive capabilities through continuous refinement.

Initially, all weights are randomly generated, and the results output from the network are likely meaningless. With known outcomes, information derived from this comparison is fed back into the network, gradually changing the weights. As training progresses, the network's transcription of known outcomes becomes increasingly accurate. Once training is complete, the network can be applied to future cases with unknown outcomes.

The architecture of a neural network can be envisioned as a multi-layered structure containing multiple nodes or neurons. Neurons are the neural network's basic processing units and the hidden layers' main components. Each neuron in the hidden layer connects input data with output data, and a single neuron can correspond to multiple inputs and outputs. However, neurons in the same hidden layer are not interconnected.

Consequently, neural networks acquire an ability to solve complex problems more accurately, such as summarizing documents or recognizing faces, mimicking the human brain's learning processes.

A simple neural network architecture is illustrated below, interconnected through three layers by artificial neurons:

**FIGURE 2-24**  
**NEURAL NETWORK ARCHITECTURE DIAGRAM**

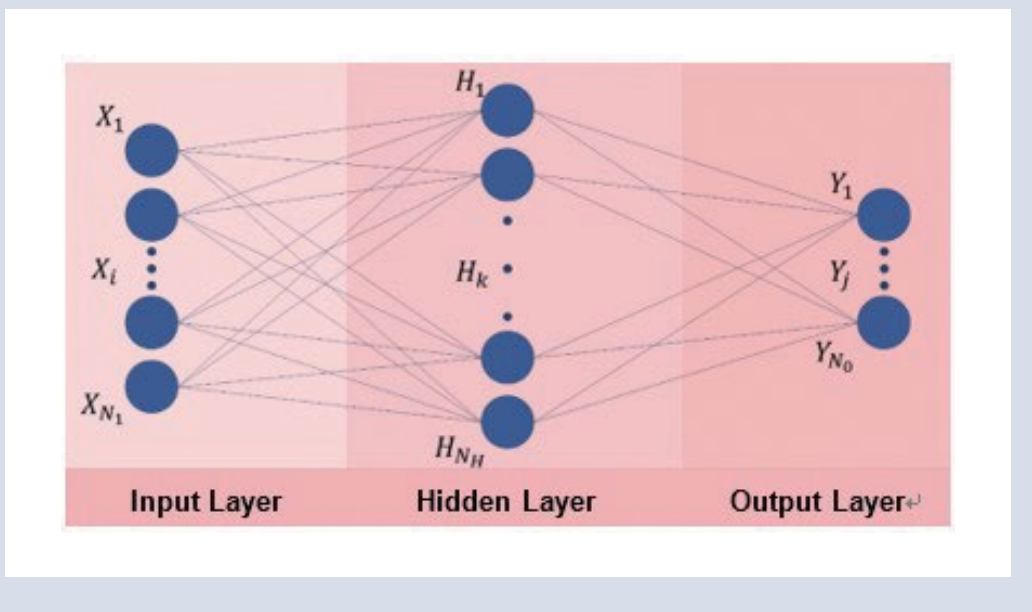

- 1. Input layer:** Information from the external world enters the neural network through the input layer. The input layer acts as the receiver of data and input messages in the network architecture, typically represented by a single layer.

The number of processing units in this layer, as shown in the diagram as  $X_1 \sim X_{(N_i)}$ , depends on the input content and is used to represent the network's input variables. The input nodes process the data and pass it on to the next layer.

- 2. Hidden layer:** The hidden layer receives inputs from the input layer or other hidden layers. Positioned between the input and output layers, it uses non-linear transformation functions.

The number of nodes in this layer, as shown in the diagram as  $H_1 \sim H_{(N_H)}$ , cannot be determined by a standard method and is usually decided through experimentation to determine the optimal number. It provides the capacity for interaction between neural network units and the ability to represent the intrinsic structure of the problem.

Neural networks can have numerous hidden layers, with each layer analyzing the previous layer's output, further processing it, and then passing it on to the next layer. However, too many hidden layers can lead to difficulties in convergence during the learning process. Generally, one to two layers are considered to have the best convergence properties.

- 3. Output layer:** The output layer presents the final results of all data processing done by the neural network. In the network architecture, it serves as the provider of data output, usually represented by a single layer. The number of processing units in this layer, as shown in the diagram as  $Y_1 \sim Y_{(N_0)}$ , depends on the content of the output and is used to represent the network's output variables.

### 2.14.4 Convolution Neural Network

Convolutional neural networks (CNNs) are a type of deep learning neural network that is particularly powerful in image recognition. CNNs can even surpass human recognition accuracy in image recognition. Many image recognition models are based on the architecture of CNNs, and their widespread use in computer vision has made them a mature technology [30].

**CNN architecture:** CNNs consist of three groups of layers: ‘convolutional layers,’ ‘pooling layers’ which reduce the dimensionality of the data by breaking it down into different parts or regions, and ‘fully connected layers’ that establish additional neural pathways between layers.

- 1. Convolutional layer:** This layer uses pre-set filter conditions to extract information from the input data. The convolutional layer consists of numerous kernels performing convolution operations on the input image, as illustrated below.

These kernels are small matrices that move across the input image and perform element-wise multiplication with the part of the image, summing up the results. This process creates a feature map that highlights specific features in the image, such as edges, textures, or specific shapes. The convolutional layer can have multiple kernels, each designed to detect different features, making it a powerful tool for initial image analysis in CNNs.

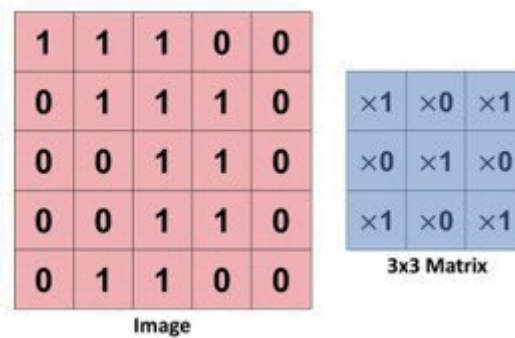

Indeed, a kernel in a CNN is also known as a filter, and the concept of a filter aligns closely with the function of the convolutional layer. In a fully connected neural network, the weights are continually updated through learning. For instance, a 3x3 filter in a CNN has nine weights. Therefore, the training process involves continually altering these filters to highlight features on the input image, performing feature extraction, as demonstrated in the figure below.

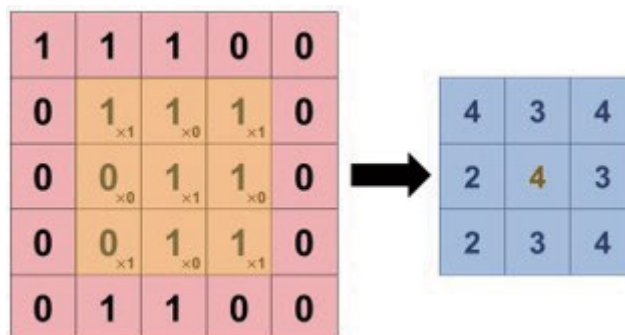



**2. Pooling layer:** Pooling, also known as subsampling, primarily serves to filter out less important features, reduce the number of model parameters, and prevent overfitting in the model. There are two common types of pooling: max pooling and mean pooling, each with its distinct characteristics and functions.

- **Max pooling:** This method involves taking the maximum value from each cluster of neurons at the prior layer. Max pooling helps reduce computational load, memory usage, and the number of parameters, minimizing the risk of overfitting. By focusing on the strongest features (the maximum values), max pooling retains the most critical aspects of the input data. (Figure 25)
- **Mean pooling:** This method calculates the average value of each cluster of neurons from the previous layer. While mean pooling also reduces the number of parameters and computational complexity, it tends to preserve the background information of the input data more than max pooling. (Figure 26)

Pooling layers are interspersed between successive convolutional layers in a CNN. Their role not only helps reduce the data size but also makes the detection of features invariant to scale and orientation changes. This invariance is crucial for robust image recognition and classification tasks.

**FIGURE 2-25**

**THE OPERATION OF MAX POOLING**

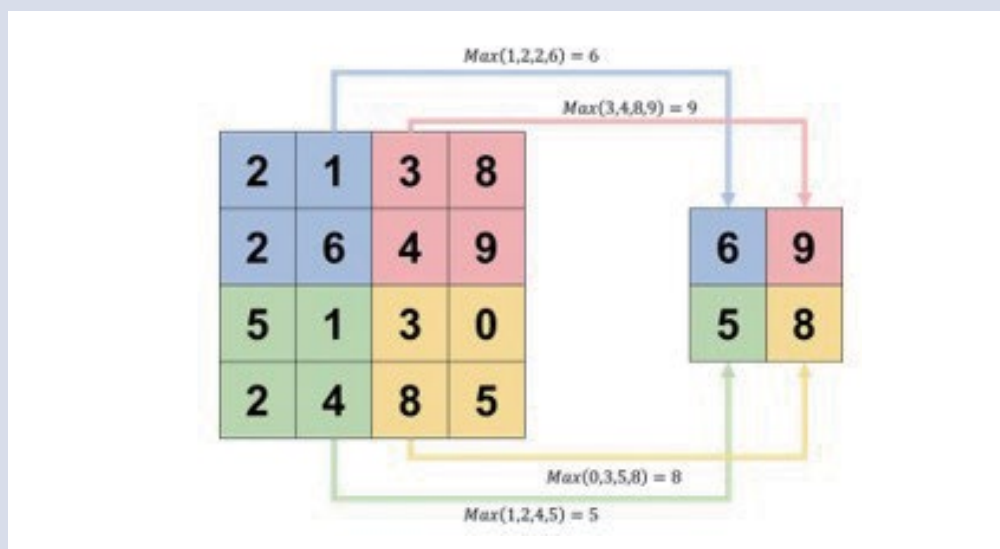

**FIGURE 2-26**  
**THE OPERATION OF MEAN POOLING**

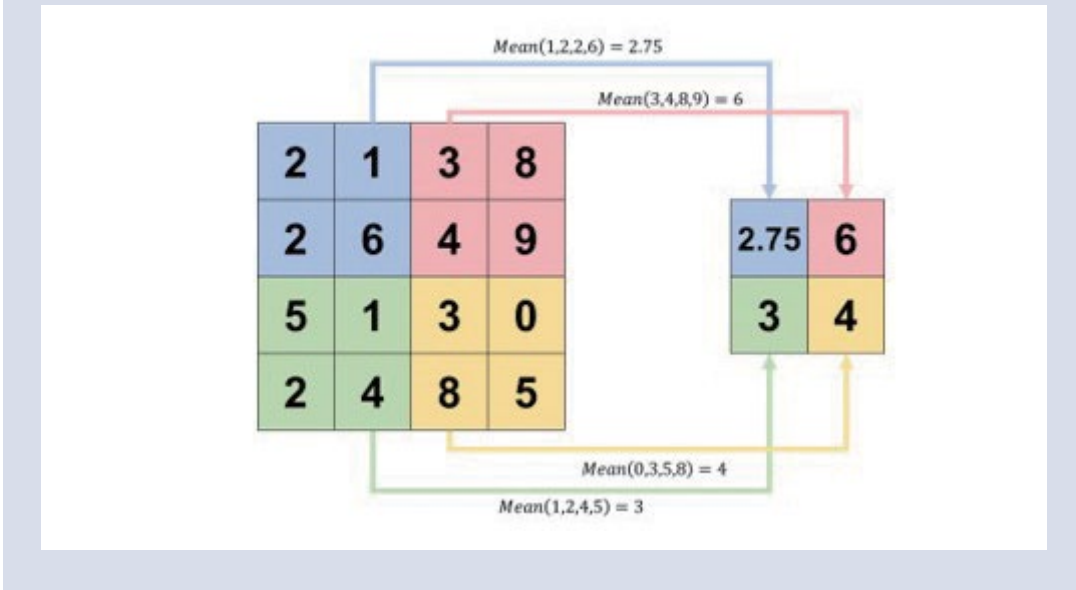

- 3. Fully connected layer:** This layer integrates the features extracted from the convolutional and pooling layers, enabling the model to perform final classification or prediction tasks. The fully connected structure allows the model to learn higher-level abstract features, thereby enhancing its understanding and judgment of images.

In the neural network architecture, when an image is input, all pixel values are treated as a one-dimensional list. Each value in this list contributes to determining the category of the image. The votes cast for different categories by all values are represented in the form of weights.

When the model evaluates a new image, it first passes through several lower layers before reaching the fully connected layer. After voting, the category with the most votes is assigned to the image.

The network can discern the intricate relationships between functions and execute predictions at a higher echelon. The CNN architecture is particularly adept for processing images and videos, as it can accommodate inputs of diverse dimensions and magnitudes.

#### 2.14.5 YOLO

The full name of YOLO is “You Only Look Once,” which signifies that a computer only needs to take a single glance at an image to perform object recognition and localization. This efficiency makes YOLO highly effective in object detection. [31]

It divides the image into numerous grid cells and then analyzes each cell to identify potential objects and their positions.



During its analysis, YOLO takes into account features such as the shape and color of objects and compares them with previously learned knowledge. Ultimately, it deduces the type and location of objects in the image.

The advantage of YOLO in object detection lies in its ability to rapidly recognize and locate objects in images, making it highly valuable in real-time applications such as autonomous driving and surveillance systems.

In addition to YOLO, there are several other deep-learning-based object detection methods, such as R-CNN, Fast R-CNN, Faster R-CNN, and Mask R-CNN, each with its own characteristics and advantages.

These models extend and optimize object detection on the foundation of CNNs. They are widely used in tasks such as object detection and recognition, contributing significantly to improvements in accuracy and efficiency.

# SECTION 3 DIGITAL KAIZEN CASE STUDIES

## The goals for this section are:

- To obtain an ability to propose and advise the client company on “what issues need to be addressed and what digital technologies should be utilized to improve current status.”
- To understand how to tie IoT technology to the business principles and challenges of the companies we support and how to envision their future.

## Chapter 3.1 Legacy Equipment Retrofit Case Study: Production Control and Abnormality Detection in an Auto Parts Company

### ✓ Summary of this Chapter

**3.1.1 Importance of Retrofit in Kaizen:** Retrofits can result in cost savings, production process optimization, improved compliance and safety, and increased flexibility to meet market needs.

**3.1.2 Current Status and Issues of Company A’s Automotive Parts Plant:** Company A, which manufactures automotive parts, has many legacy devices. Since these devices do not have a data transmission function, managing their operating status collectively is impossible, resulting in problems such as the difficulty of productivity improvement and delays in responding to abnormalities.

**3.1.3 Digital Kaizen Initiatives and Effectiveness:** Sensors extracted analog information from each facility. A system consisting of microcontrollers, gateways, LPWA communication, visualization services, and simple notification service (SNS) was constructed. The system enables the collective monitoring of the operating status of legacy facilities and prompt response to any abnormalities.

**3.1.4 Future Prospects: Next Kaizen:** The company is working on horizontal deployment to other facilities, more detailed information acquisition using optical character recognition (OCR), and kaizen in the workplace environment by installing environmental sensors.

**3.1.5 Digital Technologies Used:** LoRaWAN, webcam, OpenCV, sound sensor, digital pressure gauge, Raspberry Pi, ESP32 microcontroller, graphing tool Grafana

### 3.1.1 Importance of Retrofit in Kaizen

In companies with long histories, old equipment may have operated for many years. Retrofitting these facilities or reviving old equipment with new technologies can lead to significant kaizen. The benefits of retrofitting are described below.

- **Cost savings:** Replacing legacy equipment with new equipment usually involves a large investment. Avoiding a large investment and retrofitting legacy equipment can extend the life

of the equipment and improve productivity. The overall cost may be lower than replacing it with new equipment.

- **Production process optimization:** Legacy equipment may not perform at its maximum potential due to outdated technology or design limitations. Applying the latest technology can improve productivity, quality, and overall performance.
- **Compliance and safety:** Compliance and safety standards are changing with the times. Bringing legacy equipment into compliance with new standards through retrofits can improve worker safety and reduce risk to the company.
- **Increased flexibility in response to market needs:** Society's needs are constantly changing. Companies must continuously produce products that are suited to society's needs. Modernizing production systems through retrofitting and making them flexible to society's needs will help maintain and increase a company's competitiveness.

**Sustainability and environmental impact:** Retrofits are also in line with the SDGs. In many cases, it is more advantageous to continue to use legacy equipment in a retrofit than to install new equipment in terms of reduced waste, more efficient use of resources, and lower environmental impact.

### 3.1.2 Current Status and Issues of Company A's Automotive Parts Plant

This case study describes the efforts of a well-established company with many legacy pieces of equipment that implemented digital technology to retrofit them and achieve Digital Kaizen in production control and anomaly detection.

#### • Overview of Company A

<b>Business</b>	Development, design, manufacture and sales of automotive parts	
<b>Number of employees</b>	Approx. 100 people	
<b>Establishment</b>	Around 1960	

#### • Issues of the Parts Plant: not knowing the operation status of these old machines

Company A is a long-established company that has been in business for 60 years. As a result, many of the production facilities were old, and retrieving and collectively managing operating information was impossible, causing various problems. In particular, the company faced the challenge of improving four pieces of equipment: an assembly machine, a flow soldering machine, an aging furnace, and an air compressor.

#### ✓ Four issues:

- (1) Abnormalities of assembling machines are displayed only on the signal tower.
- (2) The operation status of the flow soldering machine is displayed only on the counter, and the maintenance time is unknown.
- (3) Errors of the aging furnace are notified only by buzzer; only a person nearby can realize
- (4) Air compressor pressure abnormality is not detected.

The following are descriptions of these four issues.

**(1) Abnormalities of assembling machines are displayed only on the signal tower.**

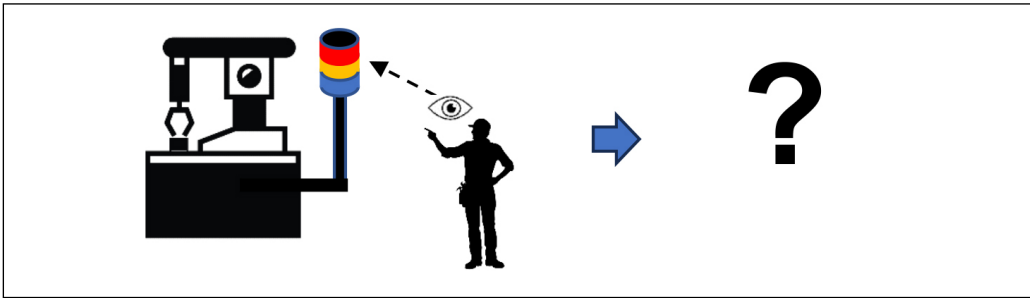

Company A uses machines to perform some of the assembly of automotive parts. When a machine stopped due to an abnormality, it would only be indicated by a signal tower, and the worker would have to find it visually. This made it difficult to respond quickly to abnormalities, and it was also difficult to know the frequency of such stoppages.

**(2) The operation status of the flow soldering machine is displayed only on the counter, and the maintenance time is unknown.**



In the flow soldering machine, as the machine runs, the solder oxidizes, and unwanted oxides, called dross, accumulate and float on the surface of the solder bath, requiring cleaning and removal as necessary. However, the machine’s operating status was displayed only on a counter installed in the equipment, and workers had to determine when it was time to clean the equipment visually. This caused a delay in deciding when maintenance should be performed, which affected the solder’s quality.

**(3) Errors of the aging furnace are notified only by buzzer; only a person nearby can realize.**

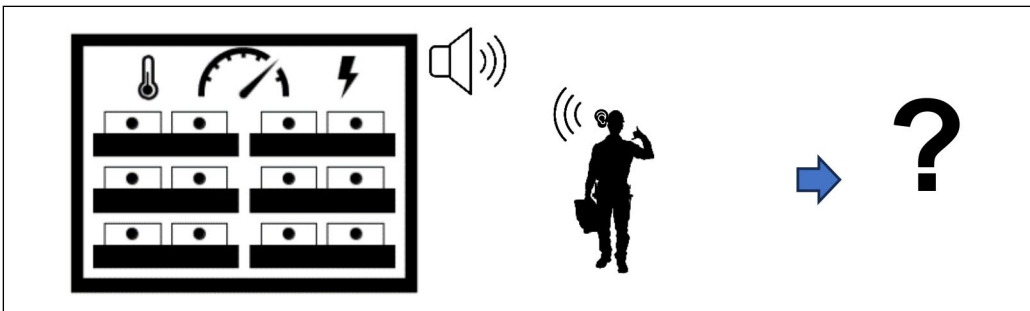

Aging tests evaluate heat resistance and durability by operating products under appropriate temperatures for extended periods of time. Before this kaizen improvement, a buzzer went off

to notify the user when an abnormality such as a temperature abnormality occurred. This system caused a problem in that only people who happened to be passing by could discover the abnormality, thus delaying its detection.

**(4) Air compressor pressure abnormality is not detected.**

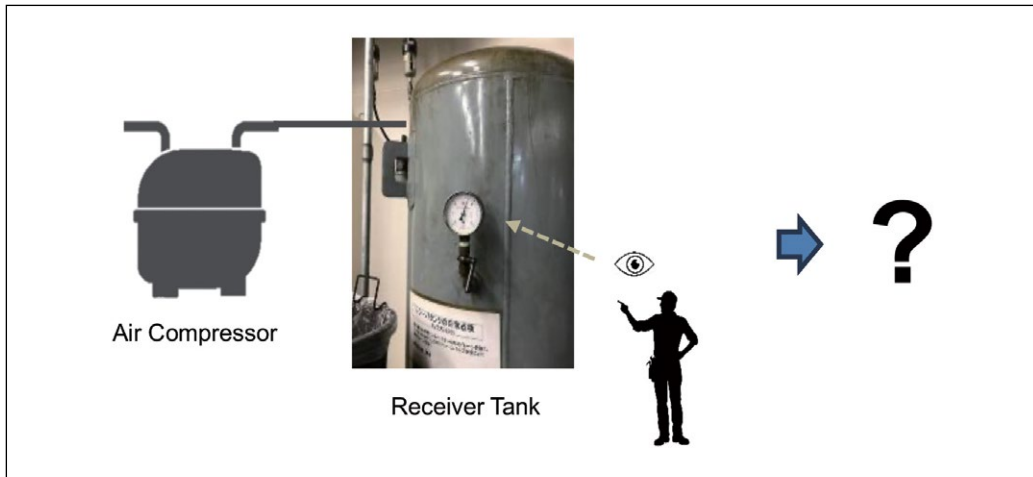

In factories, high-pressure air is used for various purposes, such as opening and closing lathes' chucks and powering transfer equipment's air cylinders. Therefore, air compressors that produce high-pressure air are indispensable equipment in factories. However, if an abnormality occurs in an air compressor, the only way to detect it is for the operator to read the pressure gauge on the receiver tank connected to the air compressor. If the air pressure drops, the operator must immediately perform an emergency stop of the line. If the emergency stop is delayed, not only will the product be defective, but the lathe or other equipment itself may be damaged.

### 3.1.3 Digital Kaizen Initiatives and Effectiveness

- **Configuration diagram of the introduced system**

Figure 1 shows a schematic diagram of the system introduced in this study.

First, a mechanism to digitize analog data from each device was constructed using sensors and microcontrollers (Raspberry Pi or ESP32).

Once the data is digitized, the data can be handled using a common mechanism. Since there were no Wi-Fi facilities in the factory, we used the LoRaWAN wireless system, a type of LPWA, to transmit data to the gateway (Raspberry Pi), sending the data to a visualization service on the Internet.

While it was necessary to write appropriate programs for acquiring information from the sensors, the communication part was common to all of them, so we could use almost the same program and proceed with the development efficiently.

**FIGURE 3-1**  
**SYSTEM DIAGRAM**

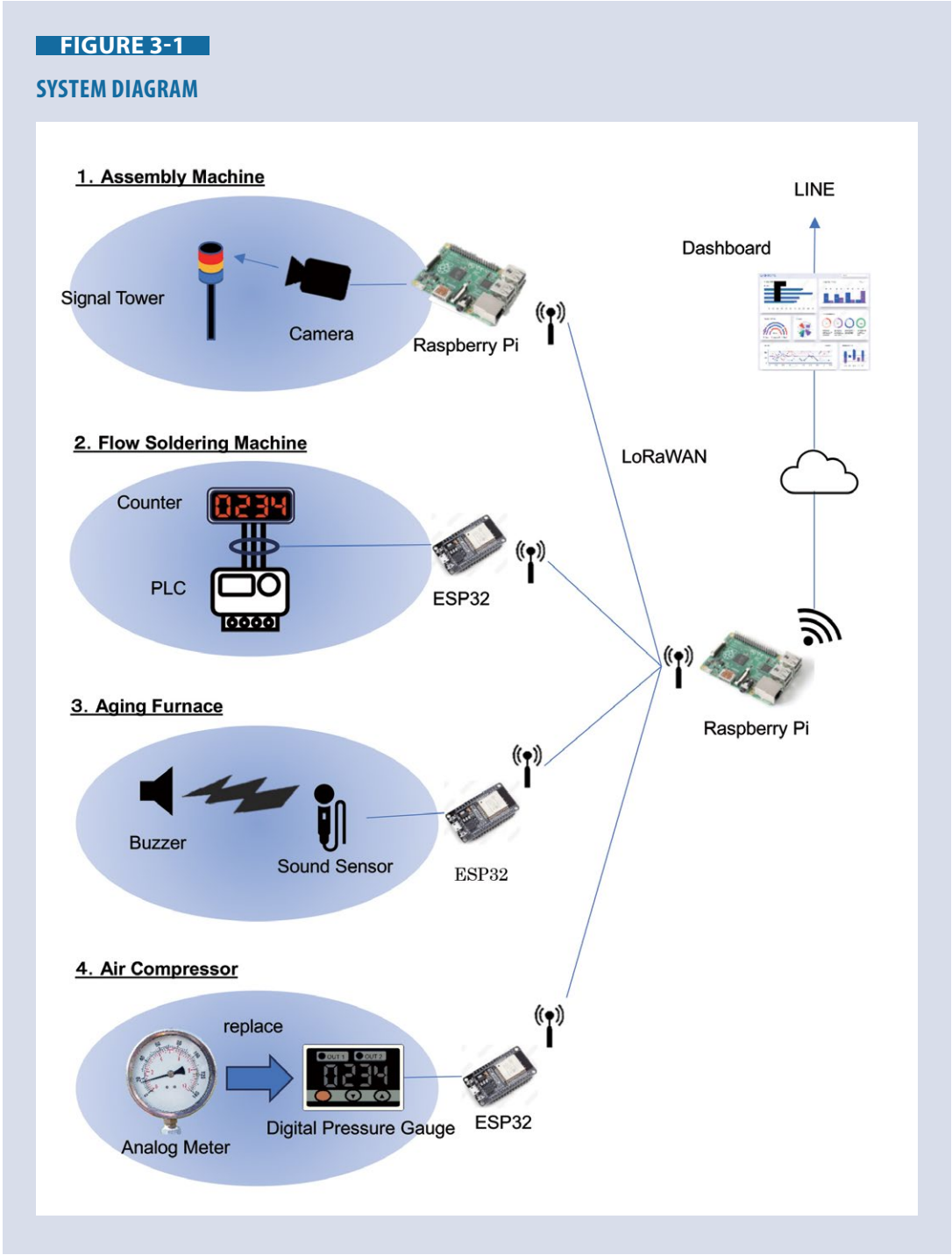

Furthermore, this system uses the notification function of the visualization service to notify LINE, a social networking service, when an abnormality occurs in the equipment (Figure 2).

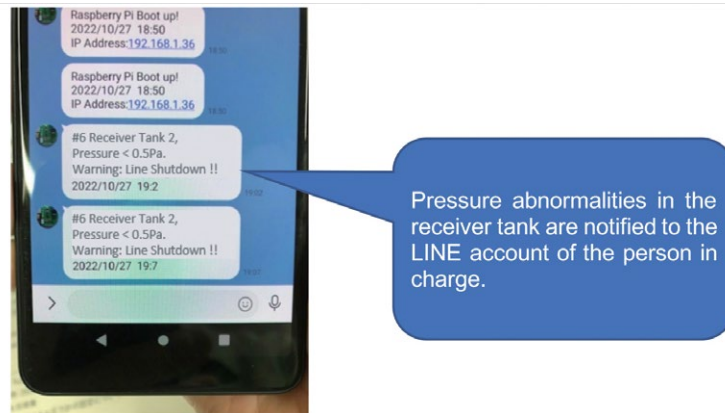
**FIGURE 3-2****ABNORMALITY NOTIFICATION ON LINE**

- **Retrieving data from each machine**

How the analog data from each machine was digitized is described below.

### 1. Assembly machine

It was difficult to extract warning signals from the control unit of the assembly machine, so we decided to use a camera to capture images of the signal tower and process them on the Raspberry Pi. The processing program was written in C++ using the OpenCV library. It analyzed the color information to detect the presence or absence of anomalies. Because image processing requires relatively high processing power, we used a Raspberry Pi instead of an ESP32.

### 2. Flow soldering machine

The signals to the counter, the status of the conveyor, the jaw cleaning pump, and the solder bath are retrieved from inside the PLC. These signals are sent to the ESP32.

**FIGURE 3-3**

**RETRIEVING SIGNALS FROM THE FLOW SOLDERING MACHINE**



**3. Aging furnace**

The aging furnace had a buzzer to alert the user to abnormalities. It was very old, and its electrical structure was unknown, making extracting a signal from the buzzer difficult. Then, we installed a sound sensor and configured it to be processed by ESP32.

**FIGURE 3-4**

**BUZZER AND SOUND SENSOR FOR AGING FURNACE**

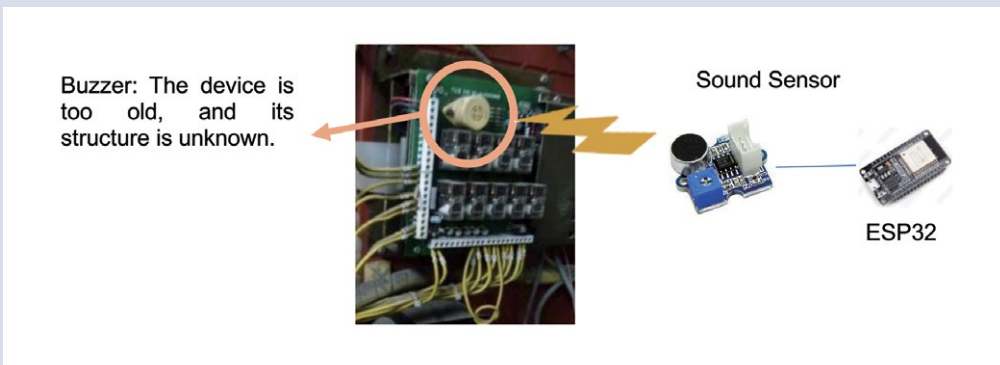



#### 4. Air compressor

High-pressure air compressed by an air compressor accumulates in a receiver tank. This is to ensure a stable supply of air to the equipment. If something goes wrong with the air compressor, the pressure in the receiver tank drops.

The analog pressure gauge installed in the receiver tank used to be read visually by the operator. A digital pressure gauge with an output function has replaced this analog pressure gauge, and ESP32 processes this data.



- **Effectiveness realized**

Until now, the operating status of these four legacy facilities could not be monitored without the operator's presence. However, with these Digital Kaizen improvements, the operating status and abnormalities of the facilities can now be checked from a PC in the office. This Digital Kaizen has made it possible to reduce the workers' workload, grasp the operating status, determine the appropriate time for maintenance, promptly address problems, and analyze the causes of problems.

Figure 6 shows the pressure fluctuations in the receiver tank on Grafana's dashboard and the audible alarm detected by the aging equipment.

**FIGURE 3-6**  
**RECEIVER TANK PRESSURE AND AGING FURNACE ALARM**

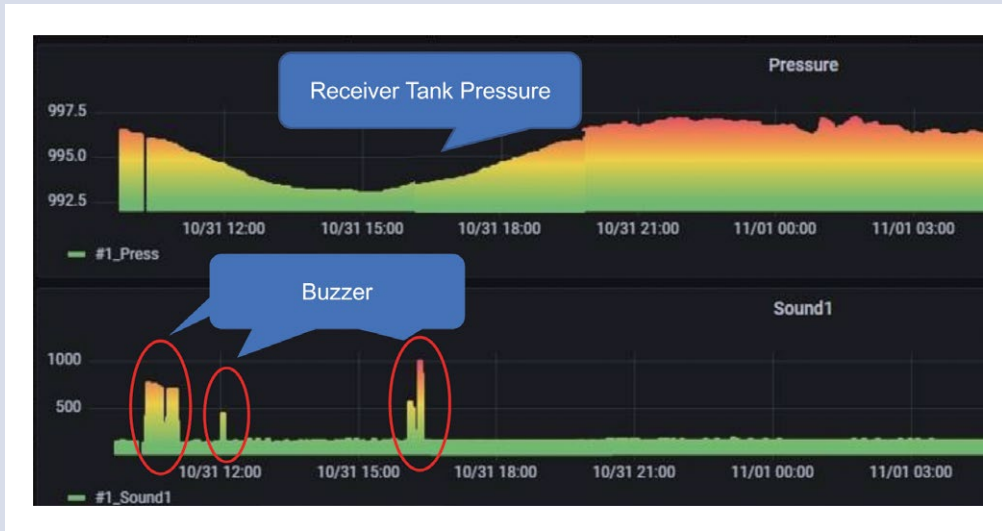

Also shown in Figure 7 is a dashboard displaying the operating status of the flow soldering equipment. You can see that not only the number of products counted, but also the status of other processes is being monitored.

**FIGURE 3-7**  
**FLOW SOLDERING MACHINE IN OPERATION**



These dashboards also make it easier for employees to work from home since they can check the operational status via the Internet.

In addition, LINE notifications have made it possible for the staff in charge to quickly identify any serious abnormalities, reducing the risk of major damage.

#### 3.1.4 Future Prospects: Next Kaizen

Company A is considering expanding the technology used in this project to equipment other than the four facilities (e.g., computer numerical control (CNC) lathes). The goal is to eventually be able to monitor all equipment in the plant.

They are also examining the possibility of using OCR to extract character information from old control panel screens to obtain even more detailed data. In addition, they have begun examining the possibility of discovering a link to defects through detailed analysis of operating information.

In addition, they have begun to improve the work environment in factories and offices by measuring temperature, humidity, and air pressure by deploying IoT equipment in various locations.

#### 3.1.5 Digital Technologies Used

- **LoRaWAN** [32]

LoRaWAN is one of the low-power, long-distance communication methods and is classified as LPWA. It is slower than Wi-Fi, with a maximum transmission speed of 250 kbps and a maximum transmission distance of about 50 km. It can be used over longer distances. In this case, LoRaWAN was used because the factory was large and had no Wi-Fi equipment. Because of the low speed, care must be taken with the amount of data to be transmitted. Normally, there is no problem in transmitting sensor data, but data transmission that requires high bandwidth, such as streaming, is not possible.

- **Web camera**

A video camera device that can be connected to a PC or other device and transmit video in real time. It is often used for videoconferencing and is generally inexpensive. In this case study, a low-cost web camera is used because it is sufficient to recognize the color of the signal tower, and durability and image capture speed are not required. An industrial camera should be considered if durability and high speed are required.

- **OpenCV** [33]

OpenCV is an open-source library for image and video processing. Intel developed it, and it is free for anyone to use. OpenCV is available for various operating systems, including Windows and Linux. In this case, OpenCV was run on a Raspberry Pi to process images of a signal tower. It can be used with languages such as C++, Java, and Python, and Python was used for programming in this case.

- **Sound sensor**

This sensor measures the sound pressure of the environment. A small microphone or piezoelectric element converts ambient sound into a voltage. Since different products have different sensitivities, checking the availability on-site is necessary. In this case, the Grove Loudness Sensor was used to detect the sound of a buzzer.

- **Digital pressure gauge**

This is a measuring instrument that can display pressure values as digital values. The instrument used in this example has an analog output, which is converted to digital by ESP32.

- **The Raspberry Pi [34]**

In this case study, Raspberry Pi is used in two locations. One location is where the signal tower's images are processed. The other is used as a gateway to transmit the data sent from each facility to the cloud via LoRaWAN. Since both applications required high-speed operation, the Raspberry Pi was used instead of an ESP32.

Raspberry Pi is a sophisticated microcontroller with Linux OS, which will be studied in detail in Chapter 4.1. The Raspberry Pi offers the same convenience and performance as a regular desktop computer but at a higher cost.

- **ESP32 [35]**

In this case study, Espressif's ESP32 is used as a microcontroller to process analog data from legacy equipment into digital data and send it to cloud services through a gateway.

The ESP32 is a small, low-cost, and highly functional microcontroller with standard Wi-Fi and Bluetooth communication functions. In this case, however, the ESP32 is combined with a LoRaWAN communication module to perform LoRaWAN communication.

ESP32 has no OS and cannot be used for independent program development like Raspberry Pi. It should also be noted that the language used is C++.

## Chapter 3.2 Production Management Kaizen Case Study: Visualization and Utilization of Production Data in a Confectionery Factory

### ✓ Summary of this Chapter

**3.2.1 Importance of production control in Kaizen:** Real-time monitoring and control of production status leads to kaizen in terms of adherence to standards, elimination of waste, real-time key performance indicator (KPI) identification, smooth production, improved maintainability, and increased motivation.

**3.2.2 Company B's Confectionery Factory: Current Status and Issues:** Company B, which manufactures and sells confectioneries, has a complex product packaging process and was faced with the challenge of improving productivity in this process. The company had been involved in quality control (QC) activities for some time, but these activities were labor-intensive, and the paper-based information sharing system made it difficult to monitor production status in real time.

**3.2.3 Digital Kaizen Initiatives and Effectiveness:** Company B installed distance sensors and microcontrollers to control them at seven locations per line in the packaging process, and constructed a real-time monitoring system that combines a database on the cloud and visualization tools to share production information in real time, detect bottlenecks, improve target and performance management, improve personnel allocation, and go paperless.

**3.2.4 Future Prospects: Next Kaizen:** Based on the know-how gained, the company is taking on the challenge of deploying IoT technology in other factories, integrating all factories using advanced cloud technology, and even implementing predictive maintenance through the introduction of AI.

**3.2.5 Digital Technologies Used:** Time of flight (ToF) distance sensor, ESP32 microcontroller, wireless LAN, AWS cloud service, Grafana graphing tool

### 3.2.1 Importance of production control in Kaizen

In order to effectively implement kaizen and obtain results, it is very important to monitor and control production status in real-time. Below we explain why.

- **Adherence to standards:** A stable production environment is necessary to sustain efficient production. To this end, it is important to create and follow written procedures for each operation. By accurately monitoring production, it is possible to verify that these procedures are being followed correctly. If the procedures are not being followed, finding out what the causes are and whether the procedures themselves need to be changed can provide important hints for the next kaizen.
- **Elimination of waste:** Various types of waste can occur in the production process. Those include overproduction, defective products, waiting time, excess inventory, and wasteful movements and transfers. By accurately monitoring and controlling the production status, these wastes can be identified, and their causes can be tracked down to clarify the next kaizen points. Steady implementation of these kaizen points will lead to elimination of waste, optimization of workflow, streamlining of processes, and further productivity improvement.

- **Real-time KPI monitoring:** By monitoring production status in real time, various KPIs can be quickly obtained, problems can be identified in real time, and immediate countermeasures can be taken if problems are found, and hints for further kaizen can be obtained. KPIs include cycle time, throughput, defect rate, etc.
- **Smooth production:** Kaizen emphasizes “just-in-time” production. This means that manufacturing processes must be smooth and seamless, with no delays or bottlenecks. This includes the process of receiving and shipping raw materials. Accurate monitoring and control of production status will help prevent production interruptions, balance workloads, and optimize work procedures, leading to higher productivity and shorter lead times.
- **Improved maintainability:** Real-time monitoring of production status enables preventive maintenance, in which equipment and devices are replaced at the appropriate end of their useful life, and predictive maintenance, in which signs of failure are detected and maintenance is performed before failure occurs. This improves maintenance productivity and prevents unexpected interruptions in production.

**Motivation:** In kaizen, it is important that all employees, regardless of their position, are engaged in kaizen activities. When production status is shared with all relevant employees and discussed freely, many kaizen tips can be found, allowing each level of personnel, including those on the shop floor, to bring their expertise to bear and motivating everyone to participate.

3.2.2 Company B’s Confectionery Factory: Current Status and Issues

• **Overview of Company B**

Company B, introduced here, is a company operating in Japan with a focus on cookies and other baked goods. The company’s strength lies in its high quality and product development capabilities, and it also actively promotes daily kaizen activities.

<b>Business</b>	Manufacture and sale of confectionery and food products, etc.
<b>Number of employees</b>	Approx. 100 people (total group: approx. 1,000 people)
<b>Capital stock</b>	50 million yen
<b>Establishment</b>	Around 1940



Company B has a well-located logistics base and, as shown in Figure 8, packages numerous confectionery products from various manufacturing plants into cans, boxes, and bags for shipping. The company handles 200 different kinds of products, amounting to more than 30,000 boxes per day. The packaging process is a complex operation that involves a mixture of automation and manual labor. How to improve this process is one of the major challenges in manufacturing. This case study introduces Company B’s digital kaizen efforts in the packaging process.

FIGURE 3-8

## POSITIONING OF THE PACKAGING PLANT

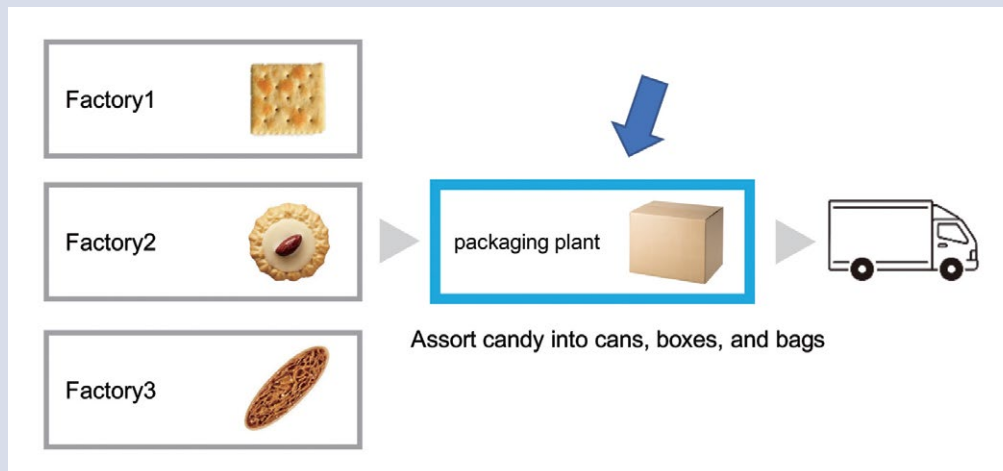

- **Packaging process**

As shown in Figure 9, Company B's packaging process consists of four processes.

FIGURE 3-9

## PACKAGING PROCESS

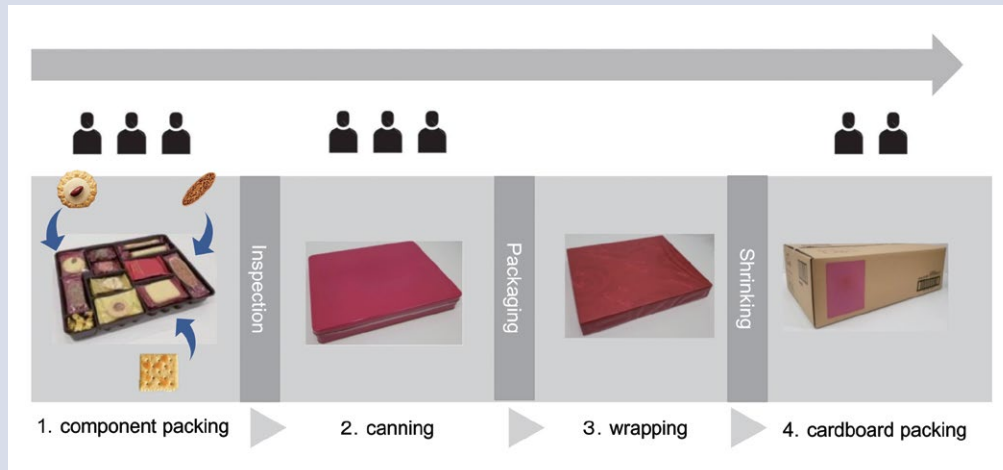

1. **Component packing process:** Workers fill trays with confectionaries, machine checks to see if they are packed correctly. (Company B refers to “confectionaries” as “components.”)
2. **Canning process:** Workers place trays into cans or boxes.
3. **Wrapping process:** Cans and boxes are wrapped in wrapping paper by a wrapping machine, and then the wrapping is tightly sealed (shrink-wrapped) by a machine.
4. **Cardboard packing process:** Workers pack goods into cardboard boxes.

Figure 10 shows how these four processes are arranged on the conveyor. Trays flow along the conveyor and are processed in sequence by workers and machines located along the conveyor. Work standards and work results are reported and shared on paper.

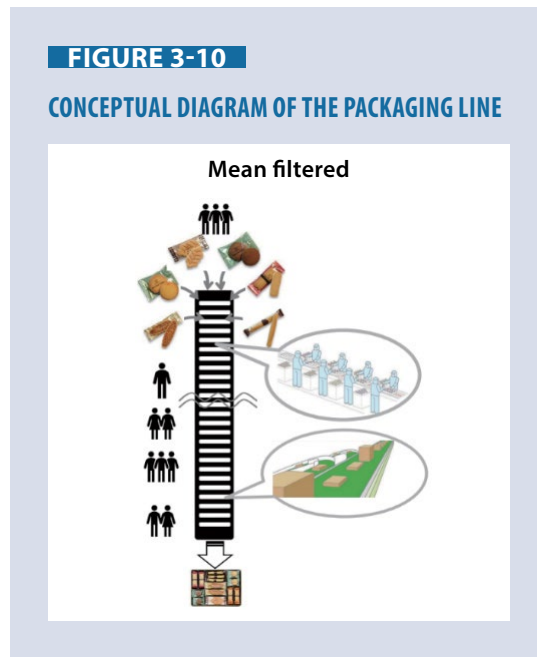

Company B has been implementing the following “analog kaizen” activities to improve productivity.

- Analyzing and addressing reasons for stoppages using QC activities and the Seven QC Tools.
- Measuring work time with a stopwatch

- **Issues**

While the “analog kaizen” activities have achieved a certain level of success, the following issues have also been identified.

- **Data analysis of QC activities is time consuming.**
- **Measuring work time with a stopwatch is labor-intensive and causes measurement errors.**
- **Difficulty in understanding the overall condition of the production line**
- **Lack of real-time information and delays in dealing with problems.**

To solve these issues, Company B’s Information System Department members first attended an IoT training course at a public institution to learn basic knowledge about the IoT. Then, the members who had taken the course conducted in-house training to educate those who had not yet taken the course.

Next, they launched a “Productivity Improvement Project” in collaboration with on-site members of the packaging line to examine how IoT technology could be utilized for kaizen on this line. The following is a description of the system that was realized as a result of these activities.



### 3.2.3 Digital Kaizen Initiatives and Effectiveness

- **System introduced:** To solve these problems, the “Productivity Improvement Project” planned and introduced the following digital system. (Figure 11) Company B now calls this system a “treasure.”

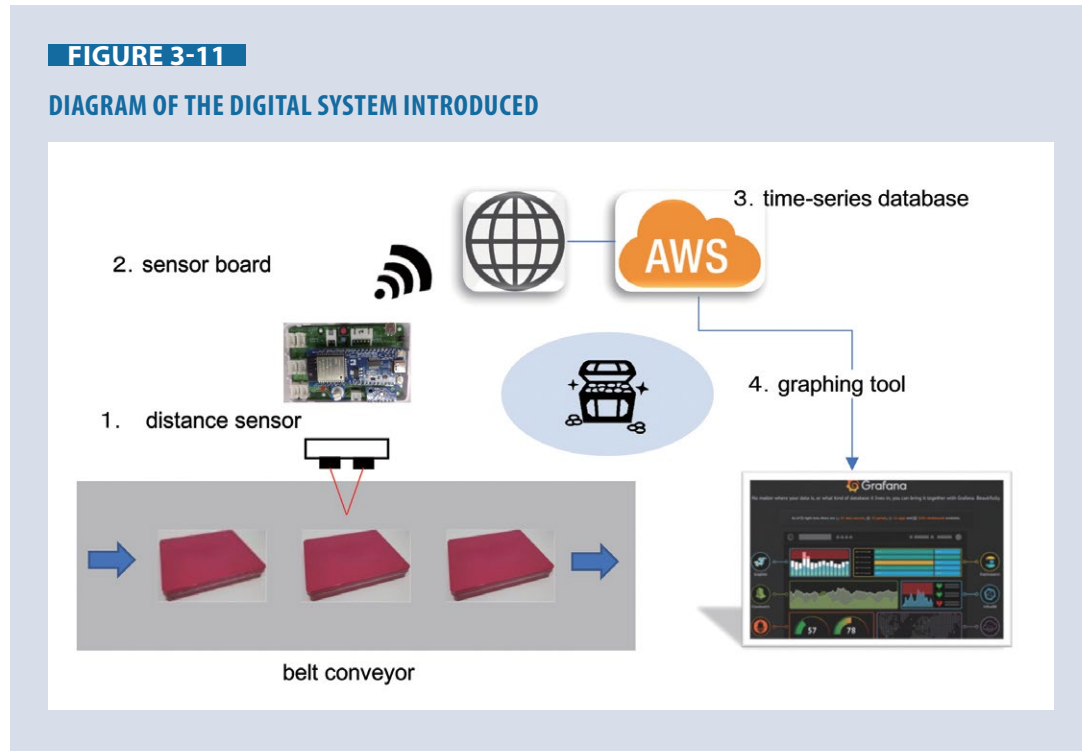

1. **Distance sensors:** The sensors are placed at seven locations on the conveyor to detect the presence of trays.
2. **Sensor board:** The board processes signals from sensors and counts products. The data is then sent to a cloud service (AWS) on the Internet via Wi-Fi.
3. **Time-series database:** Data are stored in a time-series database (Elasticsearch) on AWS.
4. **Graphing tool:** A graphing tool (Grafana) will convert the data into human-readable graphs that will be shared by relevant employees.

Below are some actual photos.

- **Distance Sensor and Sensor Board:** Figure 12 shows the actual sensor and sensor board installed on the conveyor belt of the packaging line. On the sensor board you can see a small, low-cost microcontroller (ESP32). This microcontroller is equipped with Wi-Fi and sends data to a service on the Internet through the factory network.

**FIGURE 3-12**  
**SENSORS AND SENSOR BOARDS**

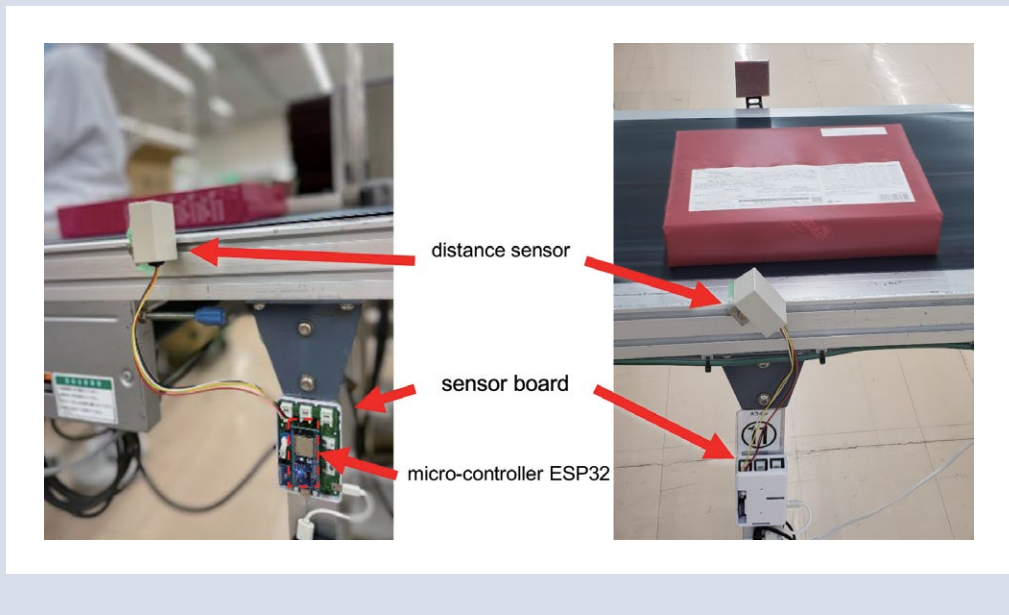

- **Sharing production data:** In Figure 13, graphs created by an Internet-based graphing service (Grafana) are displayed on monitors at the production site. These graphs can be viewed at any time by relevant employees and management, both internally and externally, with the appropriate authorization. The paper reports that used to be used have also been eliminated.

**FIGURE 3-13**  
**PRODUCTION MONITORS PLACED ON SITE**



- **Obtained Effect 1 (Detection of bottlenecks)**

Figure 14 plots the product count data obtained from each sensor. The legend on the left side shows the work process from the top to the bottom. The line from the first process, “component packing” to “canning,” is a right ascending line, indicating that the work is progressing smoothly, but the line for the “wrapping” process has dropped, indicating that production has been halted at points A, B, and C due to the failure of the packaging equipment. This reveals that the wrapping process is the bottleneck.

**FIGURE 3-14**  
TIME SERIES DATA OF PRODUCTION QUANTITY

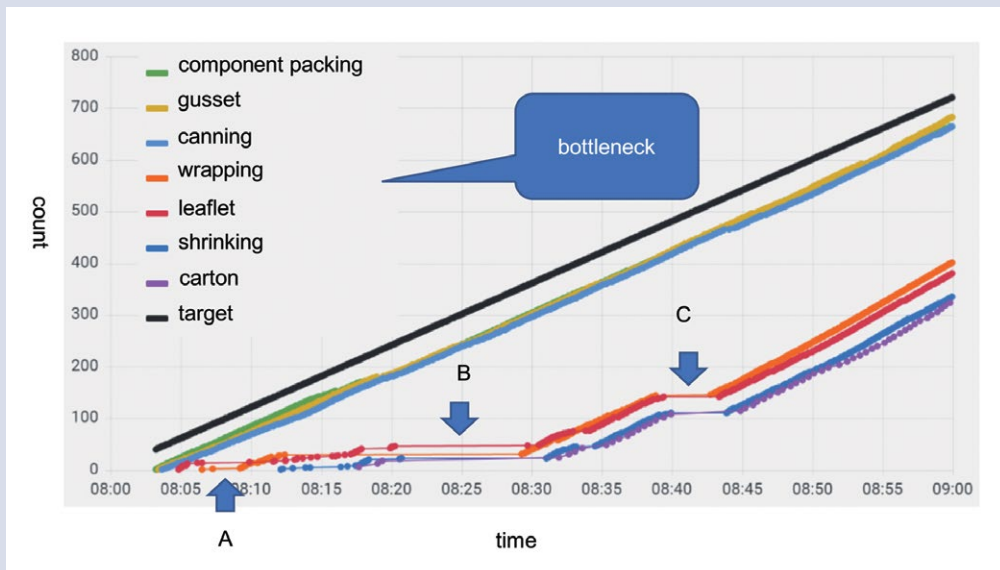

- **Obtained Effect 2 (Kaizen of target and performance management)**

Figure 15 illustrates the improved PDCA (plan, do, check, and act) cycle between target and actual values.

1. The black line indicates the production target. This graph allows you to see at a glance whether the current production is meeting the target.
2. Production results are recorded in the daily manufacturing report in real time.
3. Daily production reports are stored in the cost management system and evaluated to determine whether daily production is profitable.
4. From the cost management system, profitable targets are calculated, and these targets are periodically reviewed to further improve productivity.
5. The black dashed line shows the revised target values.

In this way, target and actual performance management, which was previously done on paper, can now be done more accurately, quickly, and effectively through the use of IoT technology. Furthermore, Company B is currently researching whether this data can be linked to predictive maintenance (i.e., predicting failures and performing maintenance).

**FIGURE 3-15**  
**MANAGEMENT OF TARGET AND ACTUAL PERFORMANCE**

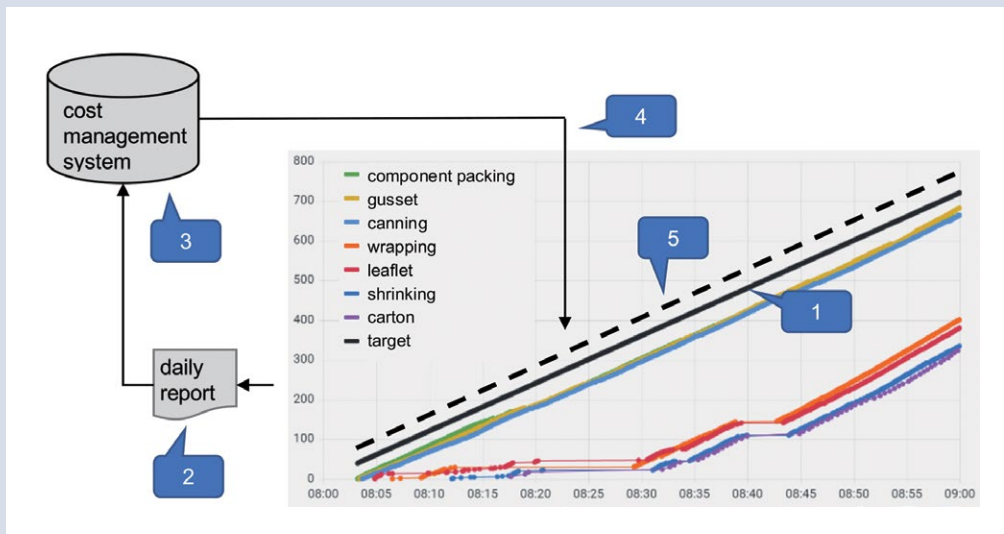

- **Obtained Effect 3 (Kaizen of staffing)**

We will now discuss staffing optimization based on Figure 16.

**FIGURE 3-16**  
**REALLOCATION OF PERSONNEL BASED ON DATA**



1. This graph shows production on target.
2. This graph shows that the production output is below the target. Since there are delays in the processes after the “component packing process,” which is the first process, it is determined that proper personnel allocation has not been made in the “component packing process” and that this process has become a bottleneck.
3. Simulation of the case of increasing the number of workers in the “component-packing process” showed that increasing the number of workers in this process and raising the current target by a certain amount would improve the total profitability of the process, so we are proceeding with process Kaizen in this direction.

### 3.2.4 Future Prospects: Next Kaizen

Company B is planning to deploy the technology and know-how gained from this project to other factories, as the kaizen project for the packaging process through IoT has been very effective. In addition, the company has begun considering a more advanced cloud system that can monitor and manage the confectionery and packaging factories in an integrated manner. They are also looking to use AI to analyze this data for predictive maintenance, demand forecasting, and delivery optimization.

### 3.2.5 Digital Technologies Used

- **Time-of-Flight (ToF) Distance Sensor**

In this case, a ToF sensor is used to detect the passage of goods. ToF sensors literally measure the distance to an object by measuring the time it takes for light to hit the object and return. While ToF sensors have advantages such as high speed, low cost, and high accuracy, they also have disadvantages such as being affected by the surface of the object and having a relatively short measurement distance.

In addition to ToF sensors, there are other sensors that count the number of parts. There are proximity sensors that determine whether a metal object is approaching, laser measurement devices that use the triangular distance measuring method, and infrared interception sensors that use light interception.

We will learn more about each sensor and how to install proximity sensors in Chapter 4.

- **Microcontroller ESP32 [35]**

In this case study, ESP32 from Espressif is used as a microcontroller that converts sensor signals into measured values and processes them to send them to cloud services.

(See also 3.1.5)

- **Wireless LAN (Wi-Fi)**

In this case, Wi-Fi was used for communication because the factory had Wi-Fi facilities in advance. However, since Wi-Fi consumes a lot of power, it may not be suitable if the power supply to the sensor is only battery-powered. In such cases, communication methods such as BLE [36] or LPWA (low-power wide-area) [37] should be considered.

- **Cloud Databases**

In this example, the data is not stored in a local database, but is sent to Amazon’s cloud service (AWS [38]) data store Elasticsearch [39]. Using the cloud service directly simplifies data management and also enhances security.

Other such cloud services include Google Cloud Platform [40] and Microsoft Azure [41], which could also be options.

- **Visualization Tools**

In this case study, Grafana [42] is used as the visualization tool, which is more suitable for graphing time-series data than other BI tools. Other options include Kibana, Microsoft Power BI [43], and Google Looker Studio [44], but the choice should be based on usage, functionality, and cost.

## Chapter 3.3 Environmental Improvement Case Study: Visualization of Environmental Parameters at a Cosmetics Company

### ✓ Summary of this Chapter

**3.3.1 Importance of Measuring Environmental Parameters in Kaizen:** Measuring environmental parameters can optimize production processes, control quality, improve energy efficiency, and ensure health and safety.

**3.3.2 Company C's Cosmetics Factory: Current Status and Issues:** Company C has successfully improved communication between sites through digital technology. However, the company thought that further application of digital technology could improve the working environment, quality control, productivity, and the quality and productivity of the company's own farms for raw material supply.

**3.3.3 Digital Kaizen Initiatives and Effectiveness:** IoT devices capable of measuring carbon dioxide (CO<sub>2</sub>) concentration, illumination, temperature, humidity, and air pressure were developed, and 30 of them were deployed indoors and outdoors. These devices were deployed indoors and outdoors, communicating via Wi-Fi indoors and LoRaWAN outdoors and recording the measured data in a database on the cloud. The data is displayed on a dashboard created by a visualization tool and can be shared within the company. They are currently acquiring and analyzing the data, and we have already discovered some data that can lead to kaizen.

**3.3.4 Future Prospects: Next Kaizen:** IoT devices will be further increased, and their size will be reduced. In addition, data analysis will be developed and linked to specific kaizen activities. Furthermore, machine learning will be performed based on the accumulated data to predict productivity fluctuations and abnormalities.

**3.3.5 Digital Technologies Used:** CO<sub>2</sub> sensor, temperature/humidity sensor, illumination sensor, pressure sensor, wireless LAN, LoRaWAN, Raspberry Pi, ESP32, AWS IoT Core, DynamoDB, Amazon SNS, Kibana, Power BI

### 3.3.1 Importance of Measuring Environmental Parameters in Kaizen

Measuring environmental parameters is important in kaizen activities. The reasons for this are explained below.

- **Production process optimization:** Environmental parameters such as temperature and humidity are closely related to efficiency and quality in many production processes. By measuring these parameters, we can find the optimal conditions for production. For example,



some production systems require specific temperature and humidity levels to ensure material handling, quality, and equipment performance. It is possible to fine-tune these processes by measuring environmental parameters, leading to Kaizen in the overall production process.

- **Quality control:** Environmental parameters can have a direct impact on product quality. Fluctuations in temperature and humidity can affect product stability, yield, and efficiency of material and component utilization. Measuring environmental parameters can help ensure that products meet required specifications, detect changes that lead to defects, and take immediate action.
- **Energy efficiency improvement:** Environmental parameters are directly linked to energy consumption. By measuring environmental parameters, areas of inefficiency can be detected. For example, excessively high or low room temperatures are some of those cases. By analyzing the relationship between environmental parameters and energy consumption, effective energy conservation measures can be implemented, leading to cost reductions.
- **Health and safety:** Some production systems must follow standards to ensure employee safety. For example, certain chemicals must be strictly controlled to avoid posing a hazard to employees. Measuring environmental parameters can help ensure that the work environment complies with regulations. Even if not established as regulations, measuring environmental parameters to ensure a comfortable work environment will improve employee health and motivation, ultimately, leading to securing human resources.

### 3.3.2 Company C's Cosmetics Factory: Current Status and Issues

- **Overview of Company C**

<b>Business</b>	Production and sales of cosmetics and health foods
<b>Number of employees</b>	Approx. 300 people
<b>Capital stock</b>	100 million yen
<b>Establishment</b>	Around 1970



Company C produces and sells high-quality, high-value-added cosmetics and health foods. In particular, the company's mission is to provide products and propose lifestyles that help people lead healthy and vibrant lives, emphasizing harmony between humans and nature. Under this mission, the company is constantly learning and growing with regard to its production system, based on the concept of a "learning factory." In this case study, we will introduce their internal environmental kaizen efforts using digital technology.

As shown in Figure 17, Company C consists of four locations, each performing a unique function: the headquarters, the research center, the factory, and the farm. The headquarters is responsible for company-wide administrative and sales functions, while the research center develops new products. The factory is in charge of product manufacturing and also owns a farm where organic vegetables are grown for use in the company's products. These sites work together to develop E Corp.'s business.

**FIGURE 3-17**  
**MAJOR LOCATIONS OF COMPANY C**

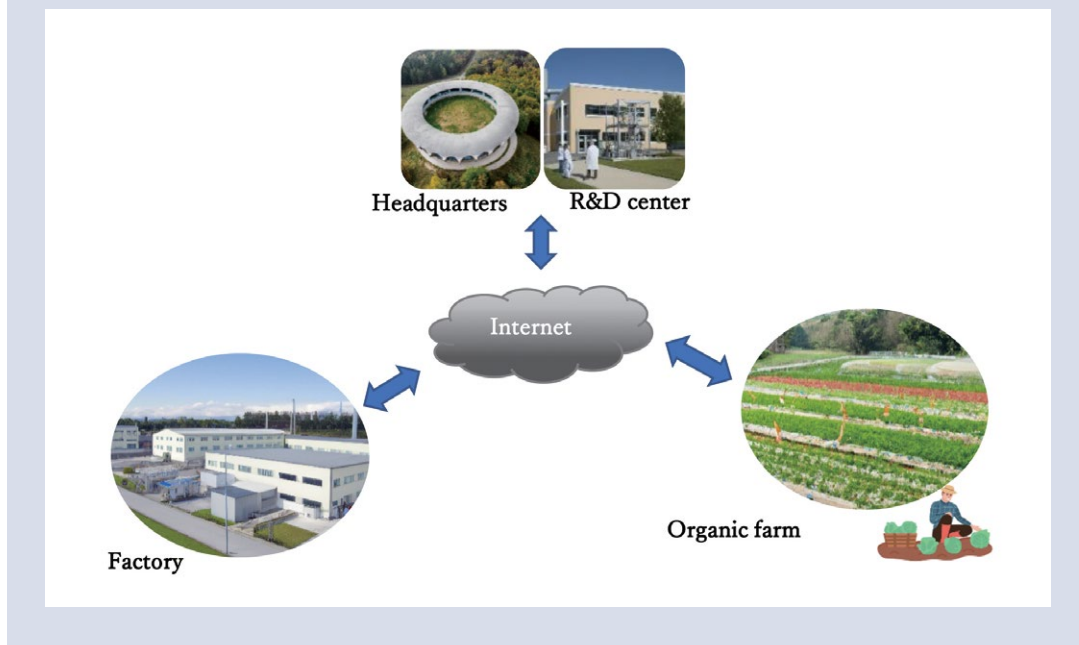

- **Issues**

Company C believes smooth information exchange between these bases is necessary and has been making various efforts. For example, cameras have been installed in the factory's offices, meeting rooms, and the research center to share images at all times. The operating status of each piece of manufacturing equipment at the factory is measured in detail using Raspberry Pis and shared within the company. Through these efforts, Company C has realized that "visualization through digital technology" significantly enhances a sense of unity and motivation among the employees.

Company C thought it could improve the situation further by monitoring, sharing, and analyzing the various conditions at these locations in more detail. Then, they started working on new kaizen initiatives. Specifically, the following issues were discussed.

- If the distribution of detailed environmental parameters (temperature, humidity, air pressure, CO<sub>2</sub>, illumination, etc.) in factory floors and offices could be determined, it would improve comfort in the work environment and more efficient air conditioning management.
- By measuring the environmental parameters of warehouses, storage rooms, refrigerators, etc., in more detail, improving quality control and productivity levels may be possible.
- Measuring soil temperatures on farms could improve crop yields and quality.

Company C began developing a visualization system for environmental parameters in the hope that it would solve the above issues.



### 3.3.3 Digital Kaizen Initiatives and Effectiveness

- **Overall configuration diagram of the developed system**

Figure 18 shows a diagram of the entire system introduced this time.

#### 1. Indoors

The orange area in Figure 18 shows the developed system in the factory. IoT devices are installed in 30 locations in the factory, and sensors on the IoT devices measure five parameters: temperature, humidity, illumination, air pressure, and CO<sub>2</sub> concentration.

These IoT devices also have Wi-Fi communication capabilities and transmit data to cloud services on the Internet through Wi-Fi access points.

In addition, a gateway has been installed. This is for communication with outdoor IoT devices. Since the communication between the gateway and the outdoor IoT devices is over a long distance and the outdoor IoT devices operate on batteries, a communication method called LoRaWAN, which is capable of long-distance communication and saves power, is used.

The gateway (described later) sends information obtained from outdoor IoT devices via Wi-Fi to a cloud service on the Internet.

#### 2. Outdoors

The green area at the bottom of Figure 18 shows the outdoor system. The outdoor IoT devices measure environmental parameters around the company and the farm's soil parameters and transmit them to the gateway. Low power consumption of the IoT devices is important, as they cannot be powered outdoors and must be powered by batteries.

#### 3. The Cloud

The blue area at the top of Figure 18 shows the system in the cloud.

In this case, AWS IoT Core is used as the management system for the IoT devices to facilitate management due to the large number of IoT devices.

Data from IoT devices are stored in a NoSQL database called DynamoDB in AWS. The stored data is displayed on a dashboard created by an open-source visualization software called Kibana. This dashboard can be viewed from a PC or smartphone via the Internet.

They also use a messaging service called Amazon SNS to send messages such as anomalies to the e-mail of the person in charge. In addition, Microsoft Power BI, which has excellent analytical and AI functions, is used to analyze data.

**FIGURE 3-18**  
**OVERALL CONFIGURATION OF THE SYSTEM**

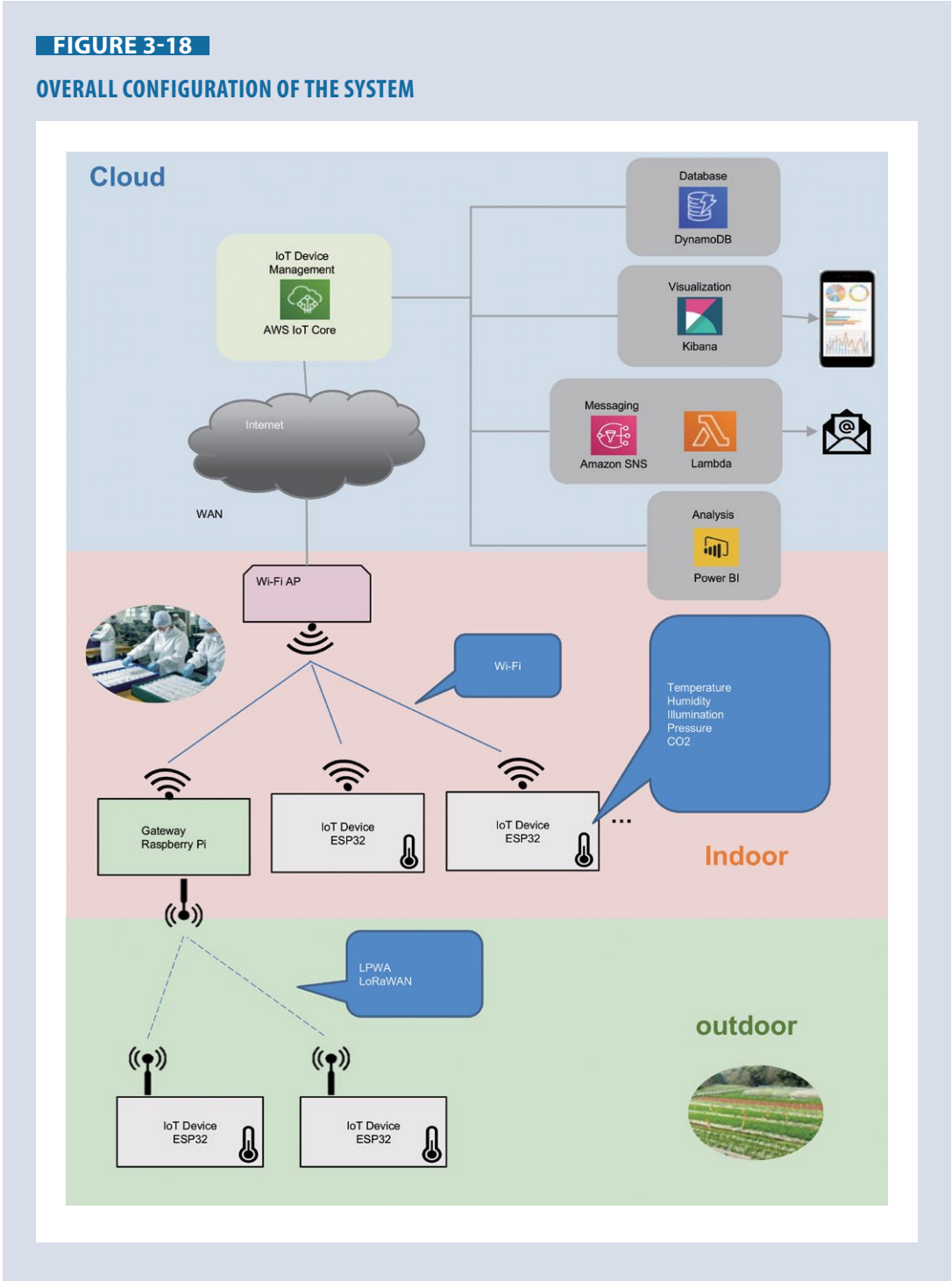

• **IoT Device Configuration**

Figure 19 shows the configuration of the gateway and the IoT device (outdoor) developed in this study. The main difference between the indoor IoT device and the outdoor IoT device is that the former uses Wi-Fi communication, and the latter uses LoRaWAN communication.

### 1. Gateway

The gateway here is a computer that relays data from other IoT devices and sends it to cloud services. We used a Raspberry Pi as the microcontroller because it requires relatively high performance and can use the factory's power supply for indoor installation, so there is no need to worry about power consumption.

The Raspberry Pi has built-in Wi-Fi communication capabilities, so it can access the Internet through an indoor Wi-Fi router. For the LoRaWAN interface for outdoor communication, they used a LoRaWAN module called ES920LR connected to the Raspberry Pi via UART.

### 2. IoT device (outdoor)

For the microcontroller of the IoT device for outdoor use, we use the ESP32, which has excellent power consumption and cost performance. For communication, we use the LoRaWAN module ES920LR in the same way as the gateway.

Other sensors and displays are also equipped on board.

- CO<sub>2</sub> sensor CCS811
- Illuminance sensor BH1750
- Temperature/humidity sensor SHT31
- Pressure sensor LPS25HD
- LCD KEEYEES OLED

The liquid-crystal display (LCD) shows the current values of environmental parameters and warnings in case of anomalies, such as room temperature exceeding threshold values.

**FIGURE 3-19**  
**IOT DEVICE CONFIGURATION DIAGRAM**

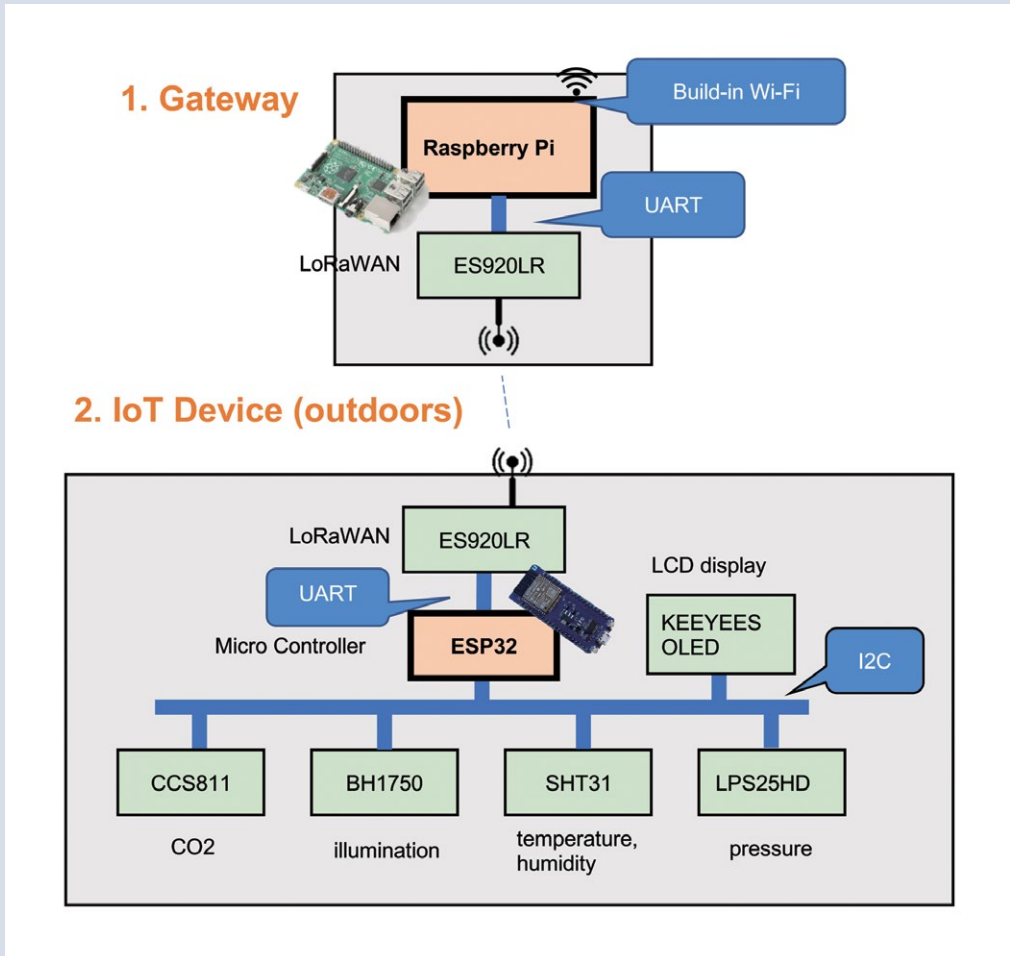

- **IoT device developed**

Figure 20 shows a photo of the developed gateway. The Raspberry Pi is placed under the case and is almost hidden in the photo. The expansion board called HAT is used to extend the functionality of the Raspberry Pi. In this case, it is used to connect a LoRaWAN module.

**FIGURE 3-20****GATEWAY****Gateway (Raspberry Pi)**

Figure 21 shows a photo of the IoT device we developed. You can see that the ESP32, LoRaWAN module, and other sensors are placed on a board developed in-house.

**FIGURE 3-21****IOT DEVICE****IoT Device (ESP32)**

Figure 22 shows a photograph of an IoT device installed on a wall inside a factory. The case is made of a transparent acrylic panel so that the inside of the device can be seen intentionally.

**FIGURE 3-22**  
**DEVICE INSTALLED ON THE WALL**

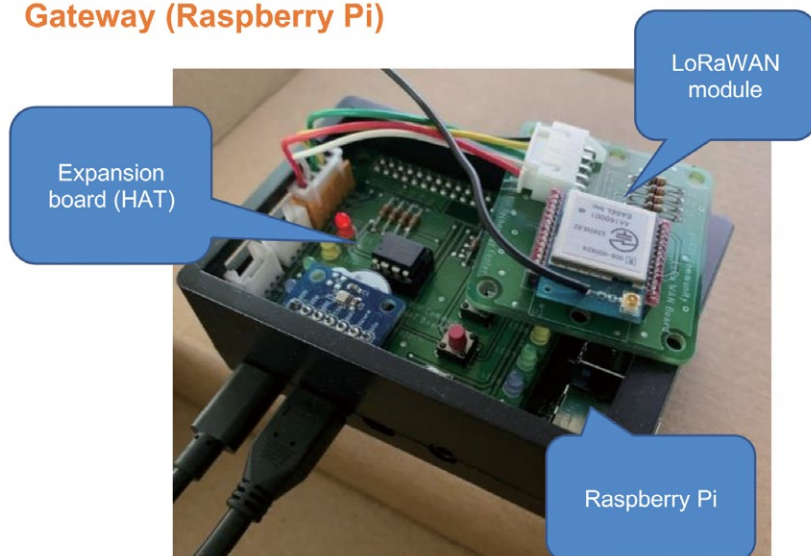

- **Dashboard**

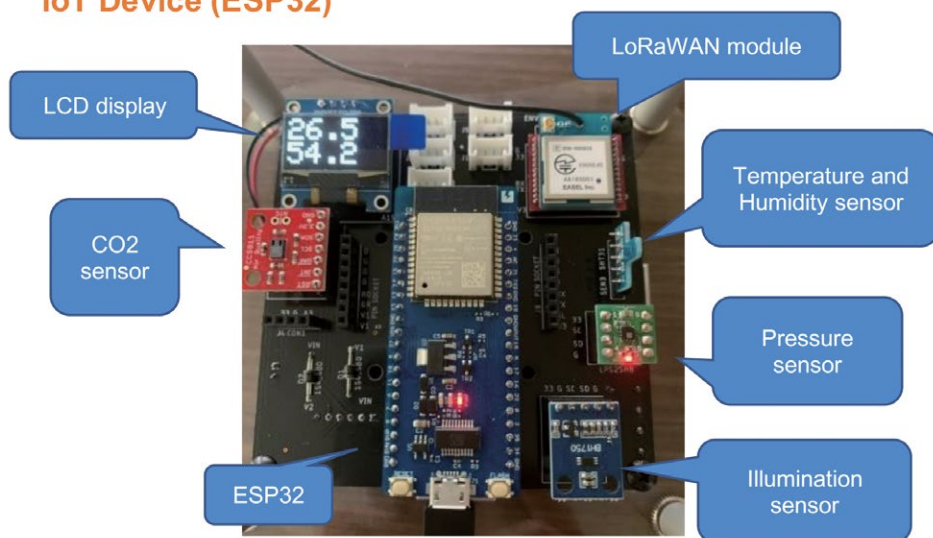
Figure 23 shows one of the dashboards created using Kibana. This dashboard displays data from a single IoT device placed at a specific location. The location name of the measurement point, date, current values of each environmental parameter, and time series data are displayed at a glance.

**FIGURE 3-23**  
**DASHBOARD (DETAIL)**



Figure 24 lists the location name, measurement time, and each measurement for all measurement points.

**FIGURE 3-24**

**DASHBOARD (LIST)**

Location	Power	Time	Temp °C	Humid %	eCO2 ppm	TVOC ppb	hPa	Lux
Production Room 1	Power	17:20:11	25.4	59	2,030	803	935	212
Production Room 2	Power	17:20:15	25.7	56	2,031	803	2935	7
Production Room 3	Power	17:20:15	25.9	53	1,921	617	936	58
Production Room 4	Power	17:20:14	25.8	58	735	51	934	5
Production Room 5	Power	17:20:14	26.3	56	813	62	935	4
Production Room 6	Power	17:20:15	27.2	45	492	13	933	3
Production Room 7	Power	17:20:15	26.6	45	486	13	934	32

In developing these dashboards, one thing is worth mentioning. That is, Kibana's visual programming capabilities mean that they did not use any JavaScript programming. Kibana can use JavaScript, but by intentionally avoiding programming, they have facilitated handover and made the system easier to maintain.

- **Obtained effects**

The first goal of this project is to develop a system that can capture environmental parameters in detail. Currently, 30 IoT devices are in pilot operation. Therefore, at this point, data acquisition and analysis are still insufficient. They have not yet reached a concrete solution to the issues discussed in “3.3.2 Company C's Cosmetics Factory: Current Status and Issues.”

However, several events demonstrated this system's effectiveness even in the process leading up to the pilot operation.

- **Quantitative identification of employee complaints:** During the test operation of this system, they received a complaint that a particular work area was hot. They then used this system to check the data from the past. They could determine at what point and to what degree the temperature rose during machine operation. Currently, they are using this data to improve the air conditioning system.
- **Detection of forgetting to turn off lights:** While observing the illuminance data, they noticed some high values even when the plant was not operating. Upon investigating the data, they found that the cause was simply forgetting to turn off the lights. Based on this finding, they have begun to consider the possibility of using the illuminance data to save electricity for the entire company.

They anticipate that many such “new insights” will emerge as they proceed with full-scale operation of the system in the future.



Although the full-scale operation of this system is yet to begin, the greatest achievement of this development is strengthening the “ability to conceptualize digitalization” of the company, technical staff, and on-site employees. We believe their ability to learn about technology, put it into practice on their own, and connect it to our management philosophy to open up the future has been greatly enhanced.

### 3.3.4 Future Prospects: Next Kaizen

Company C has identified the following items as its next steps.

1. To increase the number of IoT devices from the current 30 to 70 in the second phase and further increase the number in the third phase, aiming to expand not only to the factory but also to other locations for company-wide deployment.
2. To analyze the data and link it concretely to improving the internal environment and productivity.
3. To make IoT devices even smaller and easier to install.
4. To perform machine learning based on the accumulated data to predict the future and forecast anomalies.

### 3.3.5 Digital Technologies Used

- **CO<sub>2</sub> Sensor CCS811** [45]  
In this case study, the CO<sub>2</sub> concentration is measured as a means of air quality. In general, it is desirable to keep the CO<sub>2</sub> concentration generally below 1000ppm. The CCS811 used in this case measures total volatile organic compounds (TVOC) and is widely used as an indoor air quality monitor. However, it does not directly measure CO<sub>2</sub> concentration.
- **Temperature/Humidity Sensor SHT31** [46]  
The SHT31 is used because it is compact, power-saving, and has digital interfaces such as I2C and SPI.
- **Illuminance sensor BH1750** [47]  
The BH1750 is used to collect ambient illumination data. This sensor is widely used for adjusting the backlight of smartphones. It is small, power-saving, and has an I2C interface.
- **Pressure Sensor LPS25HD** [48]  
LPS25HD is a piezoresistive pressure sensor made with micro-electromechanical systems (MEMS) technology. It is used to measure ambient air pressure. It is small, power-saving, and has an I2C interface.
- **Wireless LAN**  
In this case, Wi-Fi was used for indoor communication because the factory had Wi-Fi facilities in advance. However, since Wi-Fi consumes a lot of power, it is unsuitable for outdoor communication. LoRaWAN, a type of LPWA, was used for outdoor communication instead.
- **LoRaWAN** [32]  
LoRaWAN was used for outdoor communication such as data transmission between the farm and the headquarters. (See also 2.1.5)
- **The Raspberry Pi** [34]  
In this case study, the Raspberry Pi is used as the gateway for receiving data from IoT devices and transferring them to a cloud server. Since these tasks require a high-speed operation, the Raspberry Pi was used instead of an ESP32. (See also 2.1.5)



- **ESP32** [35]  
One of the main reasons that ESP32 was used in this case study is its low costs. The number of IoT devices was expected to be hundreds in the future. Therefore, low-cost devices were required for this project. (See also 2.1.5)
- **AWS IoT Core** [49]  
AWS IoT Core is one of Amazon's cloud services that connects devices easily and securely interact with other cloud applications. It supports millions of devices and enables applications to keep track of and communicate with all their devices.
- **DynamoDB** [50]  
Amazon DynamoDB is a NoSQL database service provided by AWS that offers fast and predictable performance with seamless scalability. DynamoDB supports key-value and document data structures, making it a flexible option for various applications, from mobile apps to gaming to IoT.
- **Amazon SNS** [51]  
Amazon Simple Notification Service (SNS) is a cloud service provided by AWS. It supports the delivery of messages or notifications to subscribing endpoints or clients, such as e-mail addresses and mobile apps.
- **Kibana** [52]  
Kibana is an open-source data visualization tool mainly for time-series analytics. You can create and share dashboards that display charts, tables, maps, and more. Kibana is commonly used with Elasticsearch.
- **Power BI** [43]  
Power BI is a business analytics service by Microsoft. It provides interactive visualization capabilities with an interface simple enough for end users to create reports and dashboards. It allows users to connect to various data sources and create charts, graphs, and reports. It is available as a desktop application, a cloud-based service, and a mobile app.

## Chapter 3.4 Inventory Management Case Study: Introducing an RFID System in a Hand Tools Company

### ✓ Summary of this Chapter

**3.4.1 Importance of Inventory Management in Kaizen:** Inventory management plays a crucial role in Kaizen, which improves product flow, reduces waste, enhances responsiveness, etc.

**3.4.2 Current Status and Issues of Company D's Production Process:** Company D manufactures and processes hand tools. As the company primarily relies on manual labor and because of the small size of their products, there are information errors in managing production flow, leading to inefficient production management.

**3.4.3 Digital Kaizen Initiatives and Effectiveness:** The company introduced an RFID system to monitor the flow of materials and products in real-time. The system significantly contributed to operational efficiency, such as inventory control.

**3.4.4 Digital Technologies Used:** RFID (Radio Frequency Identification)

### 3.4.1 Importance of Inventory Management in Kaizen

Inventory management plays a crucial role in kaizen, which emphasizes continuous improvement in all aspects of an organization [53, 54]. In the context of kaizen, effective inventory management is important for several reasons:

- **Improves flow:** Proper inventory management ensures that materials and products move smoothly through the production process without delays and secures delivery of products. This supports the kaizen goal of streamlining operations and improving process efficiency.
- **Reduces waste:** Kaizen aims to minimize waste in all forms, including overproduction, waiting times, and excess inventory. Efficient inventory management helps identify and eliminate unnecessary stock, reducing storage costs and minimizing waste.
- **Enhances responsiveness:** By maintaining optimal inventory levels, organizations can respond more quickly to changes in customer demand, improving service levels and customer satisfaction.
- **Supports just-in-time (JIT) production:** Kaizen often incorporates JIT principles, which involve producing and delivering products just as they are needed, reducing excess inventory. Effective inventory management is essential for JIT to function properly, as it ensures that materials are available when needed without overstocking.

### 3.4.2 Current Status and Issues of Company D's Production Process

- **Overview of Company D**

Company D is a traditional processing plant that engages in the manufacturing and processing of hand tools.

<b>Business</b>	Manufacturing and processing of hand tools	
<b>Number of employees</b>	Approx. 30 people	
<b>Capital stock</b>	Around 1,000,000 USD	
<b>Establishment</b>	Around 1997	

- **Material flow process**

The company purchases finished and semi-finished products. After being purchased by the company, the materials are stored in the warehouse. The semi-finished products are then transferred to the heat treatment area to finish processing and sent for quality control inspection. The qualified products are assembled and sent to the packaging area. (Figure 25)

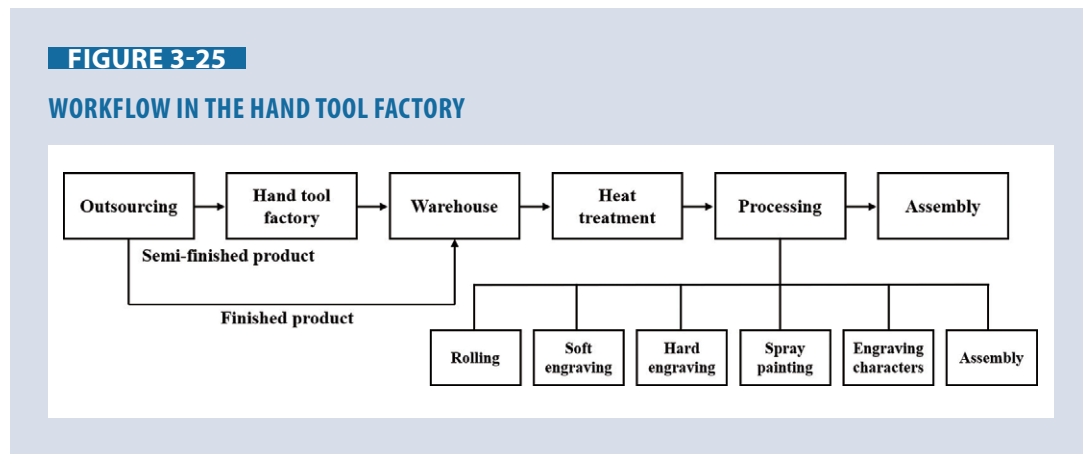

- **Current process structure**

The company's current process structure is as follows:

#### 1. Filling out the material list

When the materials arrive at the factory, the operators verify the purchase order and check if the materials match the list. Figure 26 shows the boxes of materials upon arrival at the factory, which are unloaded from the truck using a forklift. Figure 27 shows the on-site operators verifying the list and checking the materials for accuracy.

**FIGURE 3-26**  
**ARRIVAL OF MATERIALS AT THE FACTORY**



**FIGURE 3-27**  
**OPERATORS COUNTING MATERIALS**



## 2. Weighing and quantity verification

At the entrance of the warehouse is the weighing area. The operators immediately place each box of materials on the weighing scale.

They take a sample piece of the material and place it on another small weighing scale to measure the weight and dimensions, including the diameter and width.

The total weight of the entire box of materials is calculated and cross-verified with the quantity on the list (Figure 28).

**FIGURE 3-28**  
**OPERATORS ESTIMATING QUANTITY BY MEASURING MATERIALS**



### 3. Transfer to storage area

Stack the boxes that have completed the weighing procedure on a pallet and await the operators to push each box into the storage area for storage (Figure 29).

**FIGURE 3-29**

#### **PUSHING MATERIAL BOXES INTO STORAGE AREA**



### 4. Locating materials

Search for the materials based on the list outside the material boxes, verify the correctness, and send them to the processing facility or outsourcing (Figure 30).

**FIGURE 3-30**

#### **STORAGE AREA**



## 5. Record keeping

Record the quantities and specifications requested by the operators using a pen and paper (Figure 31).

**FIGURE 3-31**  
**RECORDING MATERIALS AND LOCATIONS**  
**IN THE STORAGE AREA**



- **Issues**

1. As the quantities need to be manually calculated, verified, and updated due to irregularities such as defective parts, errors by the operators can lead to discrepancies in the quantity.
2. The list affixed outside the boxes is only visible for the outermost box due to stacking in the storage area, making it difficult to view the lists on inner boxes without moving the outer ones.
3. When placing material boxes in the storage area, unclear or absent markings on the boxes make it time-consuming for operators to locate the materials.
4. Damage or deterioration of labels outside the boxes can hinder operators in identifying the materials.
5. Management personnel need to cross-verify and correct the quantity of materials while operators are extracting them, leading to a time-consuming process.

### 3.4.3 Digital Kaizen Initiatives and Effectiveness

- **Kaizen strategy**

As the company primarily relies on manual labor for hand tool production, there is a risk of errors during outbound and inbound processes due to the small size of the products.

The improvement objectives include:

1. Establishing an RFID-based material monitoring system in the hand tool manufacturing plant.
2. Linking scales to computers for automation of information [55, 56].
3. Utilizing RFID technology to achieve real-time material status and information transparency in processing plants and warehouses.
4. Reducing the generation and stagnation of excess materials after achieving information transparency.
5. Enabling real-time search capabilities to reduce manual searching and save time.

- **Hardware Architecture**

The hardware architecture consists of the Sentinel-Sense MPR-2010BR Reader, Class Generation 2 Tags, JWI-586 electronic scale, a server (host), and a TCP/IP network.

The reader used in this case is the Sentinel-Sense MPR-2010BN, a long-range wireless radiofrequency (RF) reader capable of reading most existing UHF passive tags. Its specifications and features are shown in Figure 32.

**FIGURE 3-32**

**HARDWARE SPECIFICATIONS (MPR-2010BN)**

Specifications/Model	MPR-2010BN
Product Image	
Reading Range	6m
Frequency Band	902MHz~928MHz
Data Transmission	TCP/IP
Antenna	Circularly Polarized Antenna
Number of Hopping Frequencies	50 (FCC)*
Channel Spacing	500kHz
Hopping Sequence	Pseudo Random
Communication Protocol	EPC C1G2, ISO 18000-6B/C

The handheld reader HB-1000, which can communicate via Bluetooth with personal digital assistant (PDAs) or smartphones, is capable of reading and writing RFID tags and transmitting data. Its greatest advantage lies in its mobility. The specifications are as Figure 33.

**FIGURE 3-33**  
**HARDWARE SPECIFICATIONS (HB-1000)**

Specifications/Model	HB-1000
Product Image	
Reading Range	3m
Frequency Band	902MHz~928MHz
Data Transmission	Bluetooth
Antenna	Circularly Polarized Antenna
Number of Hopping Frequencies	50 (FCC)*
Channel Spacing	500kHz
Hopping Sequence	Pseudo Random
Communication Protocol	EPC C1G2, ISO 18000-6B/C

- **System functionality**
- 1. Operational workflow in the hand tool factory**
- (1) Creation of RFID tag data**

When a new order is generated in the database, an order list is created, and a tag code is assigned (Figure 34). After editing the data, clicking “Add” automatically saves it to the database. Once the data is created, an information-filled tag is generated and handed over to the operators responsible for material entry and exit.



**FIGURE 3-34****CREATE AN ORDER**
**(2) Applying RFID tags**

When materials arrive at the factory, after inspecting the material box, RFID tags are applied based on the product specifications and quantity.

**FIGURE 3-35****RFID TAGS**

**(3) Data comparison**

Place the material box on the weighing scale, and the electronic scale and RFID reader data are transmitted to the computer for comparison. The tag is read first, confirming the data and quantity. After entering the weight of a single item and pressing “Detect,” the system checks if the weight matches the quantity (Figure 36).

**FIGURE 3-36**  
**DATA COMPARISON**

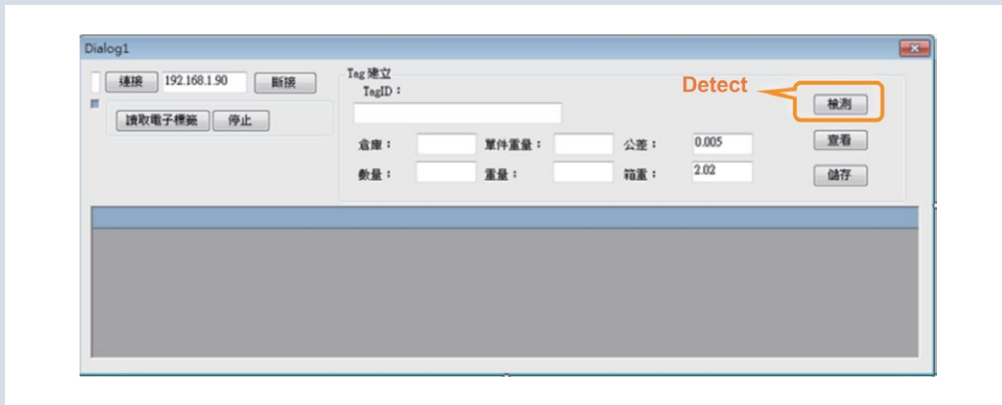

**(4) Entry into storage area**

After the comparison is completed, the material boxes are stacked on pallets and pushed into the storage area. RFID reader lanes are set up before the storage area. As the material boxes pass through, the RFID reader reads the tag on the material box and stores it in the database.

**2. In-factory record query**

A dropdown menu can be selected for the query method, and numerical values can be input for the query (Figure 37).

**FIGURE 3-37**  
**IN-FACTORY RECORD QUERY**



- **Effectiveness realized**

1. **Real-time usage inquiry**

After system implementation, backend managers can instantly check daily material usage without the need for long-term production orders.

2. **Improved operational efficiency and reduced downtime**

Managers can effectively oversee materials in real-time, reducing downtime and material delays for workers, ultimately enhancing operational efficiency. Using handheld readers, workers can quickly locate materials, saving an average of 20 hours per month.

3. **Enhanced search efficiency**

RFID technology in the material monitoring system significantly improves search efficiency, saving approximately 40% of the time workers spend searching for materials. Data entry time for managers is reduced by 50%.

4. **Effective increased production and inventory control**

The system assists in promptly identifying situations where production orders are too large, allowing managers to place orders for materials to increase shipment volume and improve production efficiency.

5. **Energy savings, carbon reduction, and cost reduction**

The system reduces the need for manual documentation and data entry, replacing it with information technology, lowering labor costs and reducing carbon footprints, ultimately reducing company costs.

#### 3.4.4 Digital Technologies Used

- **RFID** [55, 57, 58, 59, 60, 61, 62]

RFID is a technology that uses electromagnetic fields to automatically identify and track tags attached to objects. An RFID system has two main components: a tag and a reader.

1. **RFID tags:** These are small transponders that can be attached to or embedded within products, animals, or even humans. Tags contain electronically stored information, which can vary in complexity from a simple ID number to extensive data about the item to which they are attached. There are two main types of RFID tags:
  - **Passive RFID tags:** Do not have a power source. They are powered by the electromagnetic energy transmitted from an RFID reader.
  - **Active RFID tags:** Equipped with a battery that can transmit a signal to an RFID reader without needing to be powered by the reader's energy.
2. **RFID readers:** These devices send electromagnetic waves to detect and communicate with RFID tags. When a tag goes within range of a reader, it can read (and sometimes write) information on the tag. Depending on the system, the range from which a reader can communicate with a tag varies from a few centimeters to several meters.

RFID is used in various applications, including access control, inventory management, asset tracking, identification of individuals (such as in passports), and even in payment systems.

## Chapter 3.5 Equipment Monitoring Case Study: Quality Improvement by Introducing an Equipment Monitoring System to an Ultrasonic Gel Manufacturing Company

### ✓ Summary of this Chapter

**3.5.1 Importance of Equipment Monitoring in Kaizen:** Equipment monitoring is critical to kaizen, helping to enhance maintainability, efficiency, quality, safety, etc.

**3.5.2 Company E's Current Status and Issues:** Company E is a medical equipment company providing customers with high-quality standard ultrasonic bone densitometers through leasing. It is also a major supplier of medical-grade ultrasonic transmission gel for ultrasound diagnostic equipment. However, the mixing process was too complicated and required much attention from workers. They aimed to streamline this process using IoT technology.

**3.5.3 Digital Kaizen Initiatives and Effectiveness:** The company introduced a real-time motor condition monitoring and sharing system. The system significantly contributed to the three areas: quality control, management efficiency, and maintainability.

**3.5.4 Digital Technologies Used:** Variable Frequency Drive, Programmable Logic Controller

### 3.5.1 Importance of Equipment Monitoring in Kaizen

Equipment monitoring is a critical component of the continuous improvement process in kaizen, helping to enhance maintainability, efficiency, quality, and safety and ultimately contributing to an organization's overall effectiveness and competitiveness. The importance of equipment monitoring in a kaizen can be outlined as follows:

- **Preventive maintenance:** Regular monitoring helps identify potential issues before they lead to equipment failure. This proactive approach minimizes downtime and extends the life of the equipment, ensuring consistent productivity.
- **Efficiency optimization:** Monitoring equipment status allows for analyzing its operating efficiency. Insights gained can improve machine utilization, energy consumption, and overall process efficiency.
- **Quality assurance:** Equipment that is not functioning optimally can produce subpar products. By continuously monitoring the status of equipment, organizations can ensure that the quality of the output remains high.
- **Employee safety:** Regular equipment monitoring ensures that safety hazards are identified and rectified promptly, contributing to a safer workplace, a key aspect of the kaizen philosophy.

### 3.5.2 Company E's Current Status and Issues

- **Overview of Company E**

<b>Business</b>	Manufacturing Medical Equipment
<b>Number of employees</b>	Approx. 60 people
<b>Capital stock</b>	Around 660,000 USD
<b>Establishment</b>	Around 2003



Company E is a medical equipment company that provides high-quality standard ultrasonic bone densitometers to customers through leasing.

Its equipment has received FDA approval and utilizes ultrasound broadband attenuation technology to evaluate bone density and fracture risk. In its early years, the company primarily engaged in agency sales and medical equipment maintenance, focusing on leasing, agency sales, and maintenance of bone densitometers.

In 2005, Company E established its manufacturing facility for medical equipment and medical materials under its own brand. It also established a dedicated research and development department to design and develop medical equipment and materials and undertake custom contract manufacturing.

Company E is also a major supplier of medical-grade ultrasonic transmission gel required for ultrasound diagnostic equipment in various hospitals in the ROC.

- **Current Production Process**

Company E's current production process involves the coordination of multiple production operators throughout the entire production flow. Any interruptions due to employee movement can affect the overall production schedule. Sometimes, when temporary staff are unavailable, it leads to insufficient daily production.

To mitigate the risk of reduced output, overtime work may be required, leading to increased finished product inventory costs when products cannot be shipped immediately.

Production equipment operates in a single-machine production mode, and the production process is depicted in Figure 38.

The production process includes raw material inspection, mixing, viscosity adjustment, quality inspection, and packaging.

The "raw material charging and mixing" process is the most complex and prevalent in the production process and, thus, is the primary target for improvement.

The following steps describe it in detail:

1. Raw material inspection: Raw materials are inspected for specifications as soon as they arrive at the warehouse. Materials are retrieved according to customer order requirements.
2. Mixing: Raw materials are added to the mixing tank one by one according to the product standard operating instructions.
3. Quality inspection: Following a specified mixing duration, the equipment is stopped, and samples are taken for viscosity inspection according to sampling inspection standards. The viscosity of the product is checked for compliance with shipping specifications. Based on the inspection results, viscosity adjustments are made. If the product does not meet the criteria, an adjuster is added, and mixing is repeated.
4. Re-mixing: After viscosity adjustments, the equipment is reactivated for further mixing until the sample results meet the requirements. The mixing operation is then halted, and quality control personnel are notified for final inspection before shipping.
5. Packaging: Qualified products are packaged using packaging machines.
6. Motor current monitoring: During the mixing process, production personnel regularly measure the motor current values of the electric mixer to assess the mixing state. Current values are recorded before start-up, during production, and during transfer for subsequent maintenance purposes.
7. Finished product shipment: Qualified finished products are transported to the packaging machine, completing the entire production process.

**FIGURE 3-38**  
**PRODUCTION PROCESS DIAGRAM**

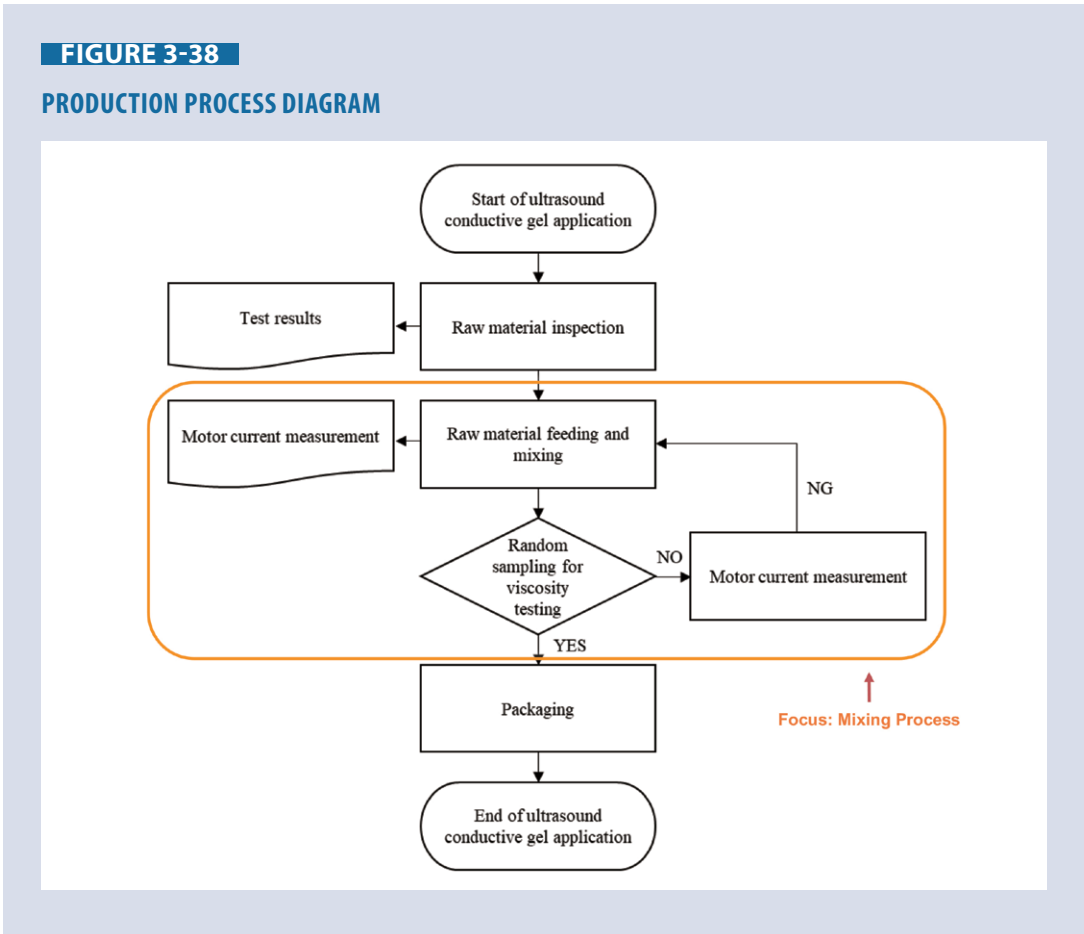

- **Issues of the mixing process**

1. There are too many steps in the mixing machine process.
2. The measurement work of the mixing machine interferes with other production tasks.
3. Real-time access to process parameters for easy review of records.
4. Reduce the need for continuous monitoring of the mixing process.
5. Early warning in case of equipment malfunctions or abnormalities.
6. Single-person operation of the production line.
7. Awareness of equipment operating status.
8. Automation to proactively detect issues with production equipment.
9. Immediate access to current equipment operation data during production.

### 3.5.3 Digital Kaizen Initiatives and Effectiveness

- **Introducing a real-time motor condition monitoring and sharing system:**

The Company aims to enhance the “Ultrasound Conductive Gel” production process to enable production personnel to engage in other tasks while the equipment is running. This necessitates transforming ideas and requirements into achievable conditions.

Specifically, it introduced a real-time motor condition monitoring and sharing system expected to contribute to quality control, management efficiency, and maintenance.

#### 1. Quality control

Based on past production records, it was found that the motor current at the beginning of the mixing process is initially low, both at the start of the stirring program and in viscosity.

After a certain stirring duration, the current increases but stabilizes, indicating that the viscosity and mixing consistency meet the shipping standards. Therefore, Company E’s R&D department decided to use the stability of motor current as a reference indicator to determine if the ultrasonic conductive gel has been adequately mixed.

**FIGURE 3-39**  
**MOTOR CURRENT**

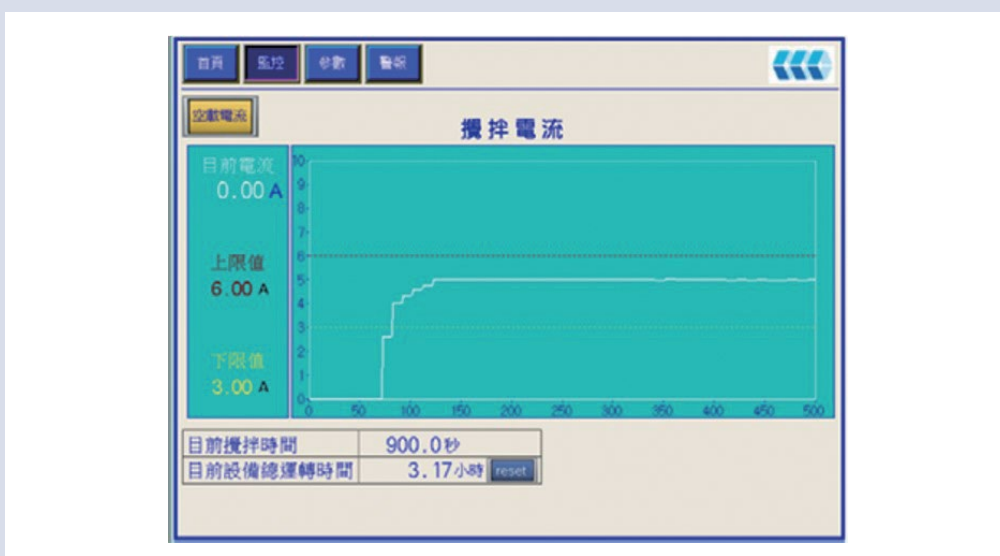

When the motor current stabilizes within a certain range, it serves as an alert to measure the viscosity of the ultrasonic conductive gel. Production supervisors and operators can observe this on the function control panel.

**2. Management efficiency**

The dashboards developed allow managers to monitor equipment operation status in the office and workspace, as shown in Figure 40.

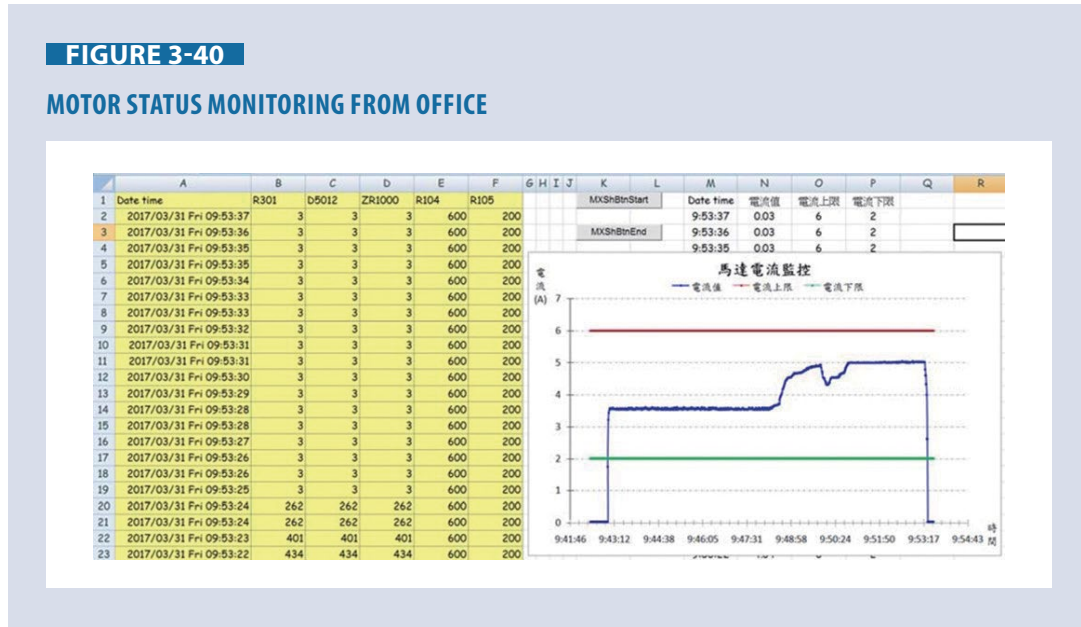
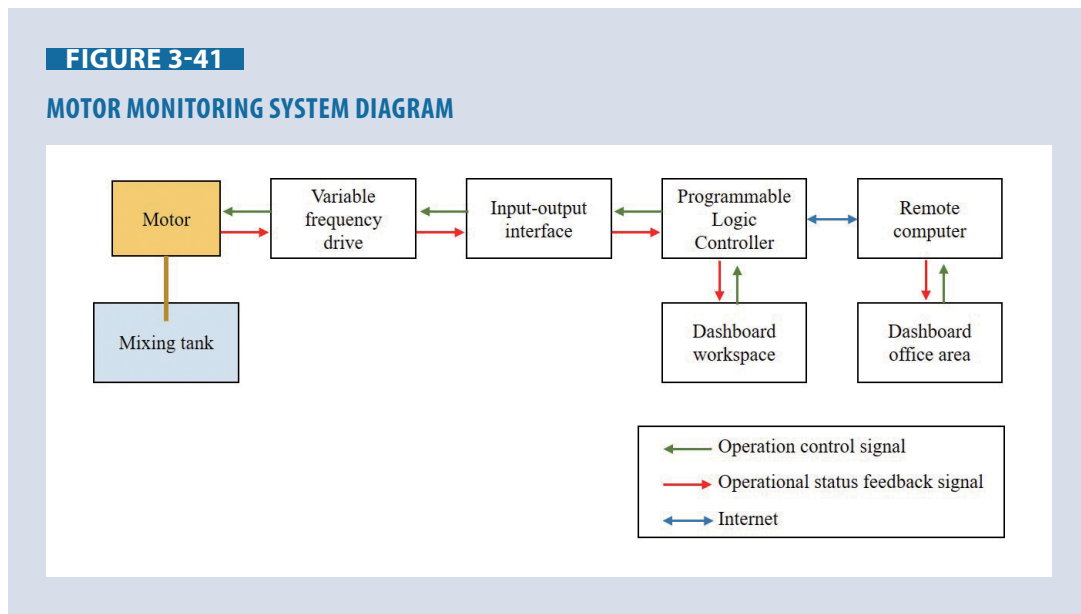

Figure 41 shows the information structure of the motor monitoring system, utilizing programmable logic controller (PLC) communication functions.





### 3. Preventive maintenance

The mechanical components of the mixing and blending tank include stirring rods, rotating bearings, transmission gears, couplings, belts, and other mechanisms. These components make up the mechanism driven by the motor to perform the mixing and blending of the ultrasonic conductive gel.

Since each mechanism ages at a different rate, regular maintenance and lubrication can extend their lifespan. Aging can cause rotational irregularities, slowing the motor speed and requiring the variable frequency drive (VFD) to increase the current and motor torque for speed control.

This change in current during each production cycle can be monitored and used as a reference for the maintenance of the mechanisms.

Prior to production, a dry run is conducted to ensure equipment functionality (Figure 42). The motor current during this test run is recorded for reference, and tracking the current during successive test runs allows the identification of mechanical aging for scheduling maintenance before the next production run.

**FIGURE 3-42**

#### DRY RUN MOTOR CURRENT

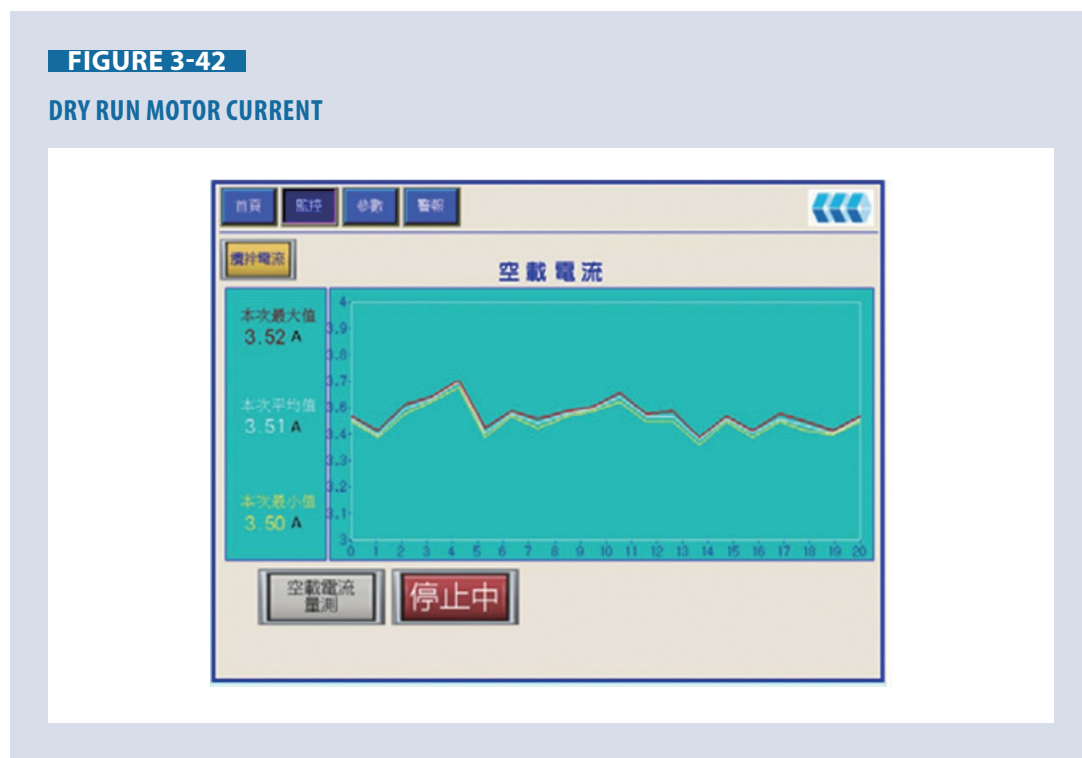

- **Effectiveness realized:**

1. Production personnel jobs were simplified, and visual the inspection burden was alleviated, stabilizing product quality.
2. Managers can now monitor the mixing process in real-time and take quick action when they find data abnormalities.
3. By closely monitoring the mixing process, they can now predict when the next maintenance is needed, reducing the cost of maintenance and downtime.

### 3.5.4 Digital Technologies Used

- **Variable frequency drive [63]**

A VFD is a type of motor controller that drives an electric motor by varying the frequency and voltage of its power supply. This allows for the precise control of the motor's speed and torque, matching the speed to the process requirements more efficiently than other means of motor control.

- **PLC [64]**

A PLC is an industrial digital computer widely used to control manufacturing processes, such as assembly lines. Modern PLCs are equipped with advanced communication functions, leading to high-level integration of production processes, as shown in this case study.

## Chapter 3.6 System Integration Case Study: Integrating Various Data and Equipment at a Metal Stamping Company

### ✓ Summary of this Chapter

**3.6.1 Importance of Information System Integration in Kaizen:** System integration plays a crucial role in kaizen. It improves data flow, enhances collaboration, supports real-time monitoring and feedback, and increases flexibility and adaptability to the market.

**3.6.2 Current Status and Issues of Company F's Production Process:** Company F has been focusing on producing and manufacturing metal stamping components, as well as process development and related mold design since its founding. Although the company implemented an enterprise resource planning (ERP) system, it has not integrated the manufacturing process. Most production-related records are manually maintained causing many problems.

**3.6.3 Digital Kaizen Initiatives and Effectiveness:** The company introduced PLCs and a manufacturing execution system (MES) in its manufacturing processes to record the relevant information regarding people, machines, materials, and other aspects generated during the production process. As a result, they succeeded in enhancing flexibility to the market, shortening response time to emergencies, monitoring production status real-time.

**3.6.4 Digital Technologies Used:** RFID, PLC, AOI (automated optical inspection), SPC (statistical process control), OCR, ERP

### 3.6.1 Importance of Information System Integration in Kaizen

System integration plays a crucial role in kaizen by ensuring that various technologies, processes, and departments within an organization are aligned and communicate effectively. Here's why system integration is vital in the context of kaizen:

- **Improves data flow:** Effective system integration allows for better data sharing and communication across different parts of the organization. With integrated systems, employees can access the data they need when they need it, leading to more informed decision-making and faster problem-solving.

- **Enhances collaboration:** System integration facilitates collaboration among all members by breaking down silos and enabling seamless communication across departments. This shared platform for communication and data exchange fosters a culture of teamwork and continuous improvement.
- **Supports real-time monitoring and feedback:** Integrated systems allow for real-time monitoring of processes and performance. This immediate feedback is crucial for the iterative nature of kaizen, as it enables organizations to quickly identify areas for improvement and make adjustments on the fly.

**Increases flexibility and adaptability:** In today's fast-paced business environment, quickly adapting to changes and new opportunities is essential. System integration provides a flexible foundation that can easily accommodate changes in processes, technologies, and business objectives.

### 3.6.2 Current Status and Issues of Company F's Production Process

- **Overview of Company F**

<b>Business</b>	Metal stamping and mold design	
<b>Number of employees</b>	Approx. 20 people	
<b>Capital stock</b>	Around 600,000 USD	
<b>Establishment</b>	Around 2002	

Company F has been focusing on producing and manufacturing metal stamping components, as well as process development and related mold design since its founding. It falls under traditional manufacturing industries, with strong mold design and development capabilities.

The company's primary customers are in the information technology industries, and through its metal processing expertise and the hard work of its employees, it has become a major supplier of stamped components to the domestic information technology industry.

- **Product Manufacturing Process**

Figure 43 illustrates Company F's product manufacturing process structure.

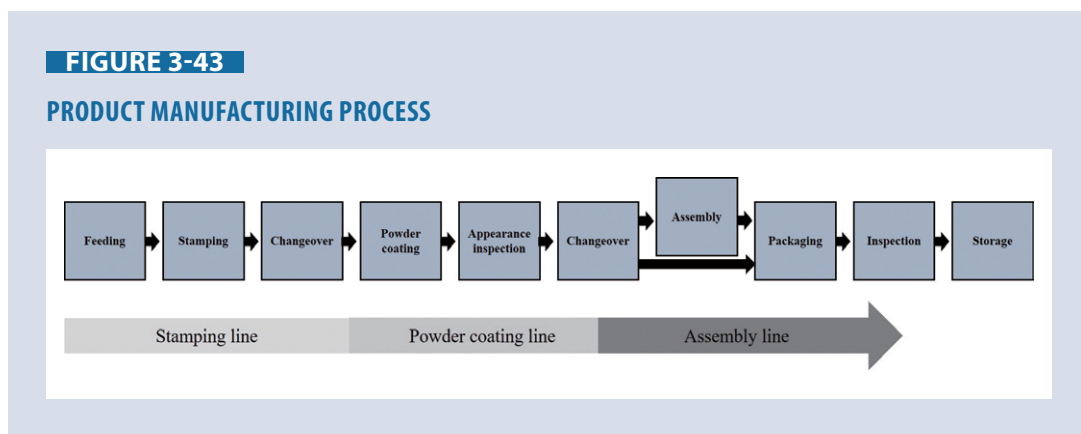

**1. Feeding**

- Raw materials are transported from the intake area to the stamping machine.

**2. Stamping**

- The stamping machine uses pre-installed molds to mechanically shape the raw material through repeated strikes, forming steel pieces.
- After the stamping process is complete, the semi-finished products are manually hung on racks, which move along tracks and proceed to the powder coating line.

**3. Powder coating**

- Semi-finished products are hung and moved along tracks to the work area, where they undergo powder coating. The color and thickness of the coating depend on product requirements, and oven time and temperature settings vary accordingly.
- Semi-finished products are paired as sets before entering the powder coating line. They are assigned an identification (ID) batch number for tracking, ensuring they meet the correct production requirements during painting or oven processes.

**4. Assembly**

- After powder coating is completed, semi-finished products are removed from the racks and transferred to a carrying tray. They are then transported to the assembly line via a conveyor belt.
- Depending on product requirements, robotic arms and manual labor are used in the assembly process.
- Assembly is carried out per the work order, and then the products move on to the packaging section.

**5. Packaging**

- After assembly is completed, products undergo assembly inspections and defect management. Other items are directly packaged.
- Before packaging, a work order material check is conducted to ensure that all components and auxiliary materials are complete, packaging labels are accurate, and the destination for shipping is correct.
- After each component and auxiliary material is confirmed to be matched, packaging is carried out.

**6. Inspection**

- After packaging, an inspection is conducted to prevent missing parts, which involves a full inspection by weight.
- Following the inspection, finished products are palletized and bundled.
- Pallet sequence numbers are linked with box numbers and work order numbers.

**7. Storage**

- After the inspection, finished products are stored in the finished goods warehouse.

- **Issues**

1. Inaccurate information caused by manual data handling.
2. RFID and barcode ID implementation cannot apply to the powder coating process.  
RFID tags cannot endure temperatures from 200 to 250 degrees for an extended duration in the coating process. QR (quick-response) codes may be covered by paint in the painting process.
3. Workers can touch unauthorized processes that may lead to inappropriate adjustments.
4. Low productivity arising from the complexity of the processes and data.

### 3.6.3 Digital Kaizen Initiatives and Effectiveness

- **Kaizen strategy**

Company F introduced PLCs and an MES in its manufacturing processes to record the relevant information regarding people, machines, materials, and other aspects generated during the production process.

- **Technologies applied**

#### 1. PLC for equipment integration

The information generated in various production processes is primarily obtained through “equipment integration.” This information includes temperature, pressure, rotational speed, and other equipment-related parameters.

The key to information transparency lies in the equipment’s ability to communicate externally, enabling bidirectional communication and integration with information systems.

Equipment relies on controllers with communication capabilities, and currently, most equipment employs PLC controllers at its core. When equipment can communicate, information systems can directly access and record relevant information most efficiently. (Figure 44)

**FIGURE 3-44**  
**SYSTEM-RELATED INFORMATION**

Production batch number		Production status		
Batch number	12-1234567	Process number	IT-200-SMT	
completion date	2023/04/12	Workstation	I01	
Workorder	A1-1234567	Description		
Parameter name	Parameter value			
speed	7200			
		Workstation	Start time	End time
		I01	2023/04/01	2023/04/10

## 2. MES

Company F has integrated its information system with the automation system to operate more intelligently, and the architecture is shown in Figure 45.

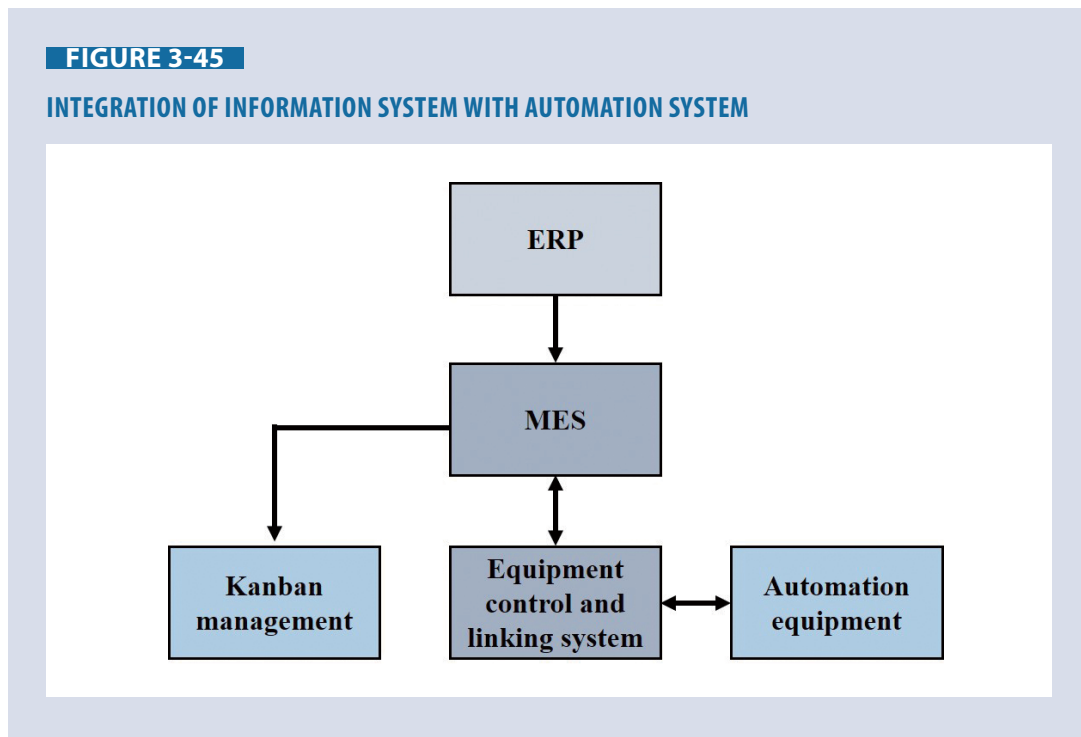

To streamline the company's operational processes, the process workflow starts from the ERP's order management. The system provides material planning and generates purchase orders for procurement. Additionally, the system generates production demand recommendations and creates work orders.

In the production information phase, the MES and equipment control are tightly integrated into the system, ensuring close connectivity and control of various automation equipment [65, 66, 67, 68, 69]. After the finished products are stocked, MES directly transfers data to generate ERP stock entry orders.

Information flow between different stages in the company's operations is made visible in real-time through electronic dashboards for both on-site personnel and managers to track orders.

Regarding order management, Company F recently signed a supply contract with its customers. The ordering process requires Company F's sales team to access the customer's supplier platform to view and download information.

The customer provides annual forecast data and actual order details on the platform, updating order and delivery plans weekly. Company F's sales team reviews and confirms these details, enabling direct upload of order information to the ERP system.

The system then automatically generates delivery plans to prevent human calculation errors. Even when the number of items increases, there is no need for additional manual maintenance.

- **Achieved system**

Company F successfully enhanced its molding process by utilizing the technologies stated above. The details of the new system are described below in the four areas: procurement management, manufacturing management, packaging management, and identification control.

### 1. Procurement management

- Manufacturing units create a daily production plan for each day of the month based on the delivery schedule. This plan includes daily targets, actual delivery/production quantities, planned production versus actual production, variances, and inventory levels.
- The quantity in the production plan takes into account production line capacity and batch planning. Material management plans are established based on the production plan and serve as the basis for material requisition for short lead time orders.
- For short lead-time procurement, purchase requests are created every two weeks and sent to suppliers. A material plan is also provided to suppliers as a reference for partial deliveries.
- Suppliers proactively produce materials according to the material plan to ensure delivery three days before production, ensuring a high delivery rate. For materials with long lead times, requisitions are made based on forecasted quantities. Material requirements planning (MRP) or advanced planning and scheduling (APS) is implemented to prevent shortages and achieve precise material planning.

### 2. Manufacturing management

The stamping line is planned as shown in Figure 46.

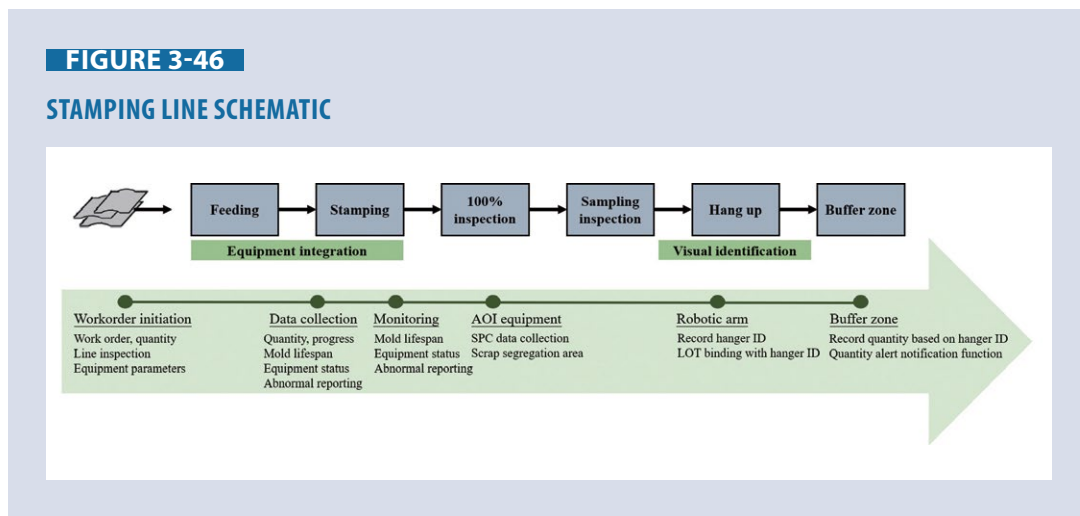

- Using ERP and MES as the core of information technology, the production plan is established based on the delivery schedule. When the ERP creates a work order, MES confirms the availability of personnel, machinery, and materials.
- Operators confirm entry into a station by reading their identification cards. Equipment status is directly reported to MES. The system sends equipment parameters and production quantities to the machine based on the production instructions on the work order. The system controls raw materials, and operators scan the barcode of the raw materials. Once the match is confirmed, the feeding machine reports the material preparation as complete.

- In case of abnormalities during trial production, the system forcibly stops production, requiring parameter adjustments or relevant actions before resuming trial production. Once the inspection confirms compliance, the system resumes production.
- Information from the stamping machine equipment is automatically fed back to the MES system. If an abnormality occurs, the system generates an alert on the screen and requests input of an abnormality report, ensuring comprehensive recording for later tracking and improvement.
- Semi-finished products, after stamping, are inspected for defects such as deviation or deformation using AOI visual inspection equipment. Inspection records are directly sent to the SPC system for collection and analysis.
- After stamping and forming, semi-finished products are placed on a hanging rack track for the powder coating process. This operation requires the recording of hanging rack IDs for process control. The hanging rack is designed in the format shown in Figure 47, with a unique number at the top, which can be accurately read using OCR.

As stated earlier, RFIDs and barcodes cannot withstand the environment in this stamping process. OCR successfully solved this problem.

**FIGURE 3-47**

**RACK DESIGN INTENT**



- The hanging of semi-finished products is performed using robotic arms. The equipment for hanging operations requires gripping capabilities, can handle relatively heavy weights, and requires a larger workspace. Therefore, a multi-axis robotic arm system is planned.
- In the temporary storage area, the track needs to have the ability to accommodate rows of hanging racks. When multiple products or components coexist, the system should also be able to balance each product's distribution.



**FIGURE 3-48**  
**POWDER COATING LINE SCHEMATIC DIAGRAM**

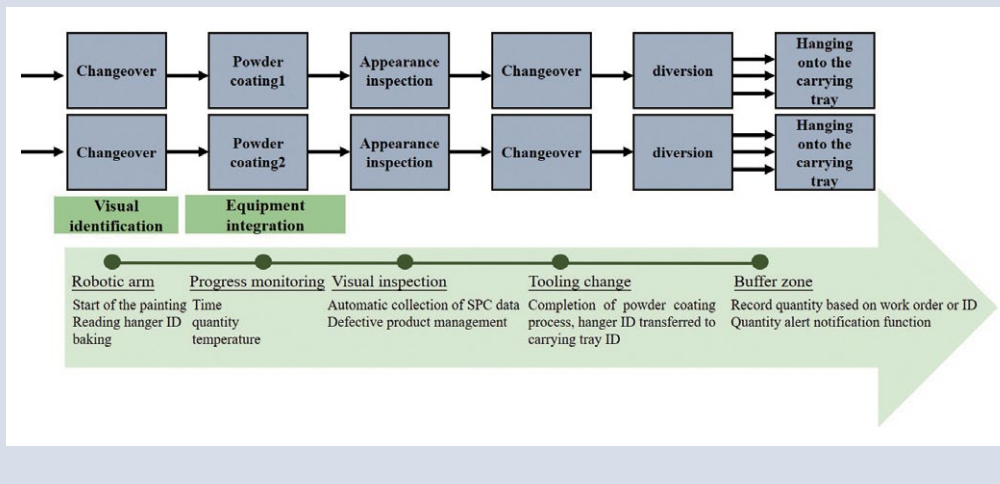

- The coating process has two identical lines to mitigate the risk of production disruption and secure minimal throughput.
  - After the semi-finished product hanging racks are lined up in the temporary storage area and enter the powder coating zone, they are first visually recognized, and the hanging rack IDs are read and recorded. The oven downloads the necessary parameters from the system, adjusts the track speed and oven temperature according to the product specifications, matches the paint color code with the work order, and directly feeds back information on the time, quantity, and temperature of each hanging rack in the oven to the system.
  - After baking and cooling, an AOI visual inspection confirms whether there are defects such as color deviation or uneven color. The inspection records are also collected in the SPC system. Once the inspection is passed, the semi-finished products are moved to the temporary storage area, prepared for diversion, and then removed from the hanging rack and transferred to a carrying tray using a robotic arm.
  - When the No. 2 Oven in the powder coating line experiences a malfunction, the oven can report its equipment status to the system without manual intervention. It automatically communicates with the equipment control system and uses the track's diverting and distribution function to send the subsequent hanging racks to the No. 1 Oven or place them in the temporary storage area while waiting.
  - When a switch to the No. 1 Oven is required, it is necessary to adjust the semi-finished product hanging rack ID accordingly, modify its production parameters, and continue production operations to avoid interruptions.

### 3. Packaging Line Management

The packaging line is shown in Figure 49.

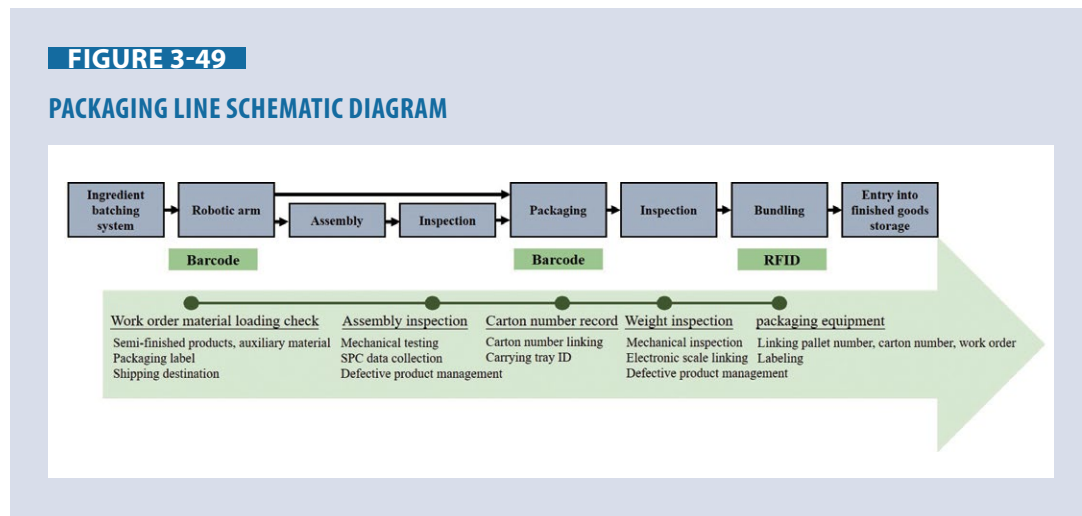

- Some products require assembly before packaging, while others can be directly packaged. Robotic arms are primarily used for assembly operations, but if the assembly process is too complex, it may involve manual assembly.
- Prior to packaging, a loading inspection is conducted, verifying aspects such as the language compatibility of instruction manuals and the correctness of packaging labels. The inspection process is confirmed using barcode reading, assessed by the system, and recorded. After confirmation, the assembly is performed, followed by durability testing, with the test records collected in the SPC system.
- In the subsequent packaging process, the material supply system provides the necessary materials, and robotic arms gather and package the products. Simultaneously, the system provides feedback on the box number and links it with the carrying tray ID, recording the information in the system.
- The barcode printer at the packaging station prints packaging labels to be affixed to the outer boxes for identification.
- After packaging is completed, an inspection process is carried out to check for missing components. The system is linked to an electronic scale, and weight limits are downloaded. The measured weight is directly transmitted to the system.
- Once the finished products are fully packaged, a final bundling and stacking process is performed. Pallets use RFID for tracking; the pallet serial number, box number, and work order number are linked. Afterward, the products can be placed in the finished goods warehouse, completing the entire production process.

#### 4. Identification control

- In personnel identification applications, active RFID is used. This includes identifying personnel and automatically recording working hours upon entering the work area.
- It also enables access control. For example, suppose one operator can operate machine W, but another operator does not have the authorization for W. In that case, the latter cannot adjust W because they lack the necessary permissions, preventing inadequate adjustment.
- **Effectiveness and awareness realized**

##### 1. Flexibility to the market was enhanced.

Market demands are gradually shifting towards small-batch, diverse, or customized production. To adapt to it, the production mode needs to change.

Production lines, equipped with sensing capabilities and guided by information systems, can cope with future scenarios like small-batch orders or frequent rush orders.

##### 2. Quick response to emergencies

In emergencies, the system can autonomously schedule and collaborate, allowing the production line to continue operating without manual intervention.

##### 3. Constant monitoring of production status

When production information, machine status, and worker reporting can be instantly reported to the system, managers can completely understand the on-site situation through MES.

When on-site personnel start operations at the workstation, the system immediately obtains and records the information. Work hours are accurately preserved in the system and can be directly used to generate reports.

The system also provides direct insights into equipment operation status or the production progress and yield of work orders. (Figure 50)

**FIGURE 3-50**

#### EQUIPMENT OPERATIONAL STATUS

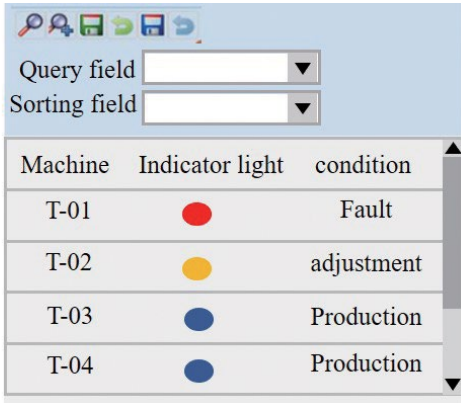

Machine	Indicator light	condition
T-01	●	Fault
T-02	●	adjustment
T-03	●	Production
T-04	●	Production

#### 4. Skilled workers are still necessary.

From the case of Company F, we observed that the introduction of automation equipment did not replace industry workers. Skilled personnel are still required to operate the automated equipment.

#### 5. Reskilling is necessary for more creative work.

The jobs of many on-site workers need to be changed. Operators who previously performed repetitive tasks started learning to operate MES systems and the human-machine interface.

Maintenance personnel started monitoring the production line from the system, enhancing their original work efficiency. On-site management personnel transitioned from being overwhelmed to being able to grasp the situation quickly through visual boards.

Higher-level supervisors can rapidly understand the operational status, including order delivery status, abnormal equipment utilization, and whether the yield is maintained at a normal level. In case of abnormal alerts, they can react faster and make clear decisions.

### 3.6.4 Digital Technologies Used

- **RFID** [57], **PLC** [64]

We observed how RFID and PLC are used for system integration in the previous chapters, Chapter 2.4 and Chapter 2.5. This chapter also uses PLC and RFID for the same purpose. See 2.4.4 for RFID and 2.5.4 for PLC.

- **AOI**

AOI is a technology used in manufacturing for the automated visual inspection of items, such as printed circuit boards, using cameras and image processing to detect defects or faults.

- **SPC**

SPC is a method used in manufacturing to monitor, control, and improve processes by collecting and analyzing statistical data to ensure consistency and quality in production.

- **OCR**

OCR analyzes an image's light and dark areas to recognize each character within the document. This enables the conversion of images of text into machine-encoded text, making it possible to search, edit, and manage the content digitally.

- **ERP**

ERP is a type of software to manage business activities such as accounting, procurement, project management, and supply chain operations. ERP systems tie together many business processes and enable data flow, ensuring that every business function relies on a single database for information.

# SECTION 4 LEARN THE TECHNOLOGY FOR DIGITAL KAIZEN

In this section, through the construction of the “Figure 1 Target System,” the goal is to gain the ability to:

- Implement concretely the Digital Kaizen examples described in Section 3
- Acquire and accumulate data using microcontrollers.
- Store data as files or databases and visualize and analyze them.
- Use appropriate cloud technologies.
- Send alerts via e-mail, etc., when abnormal values are found.

**FIGURE 4-1**

**TARGET SYSTEM**

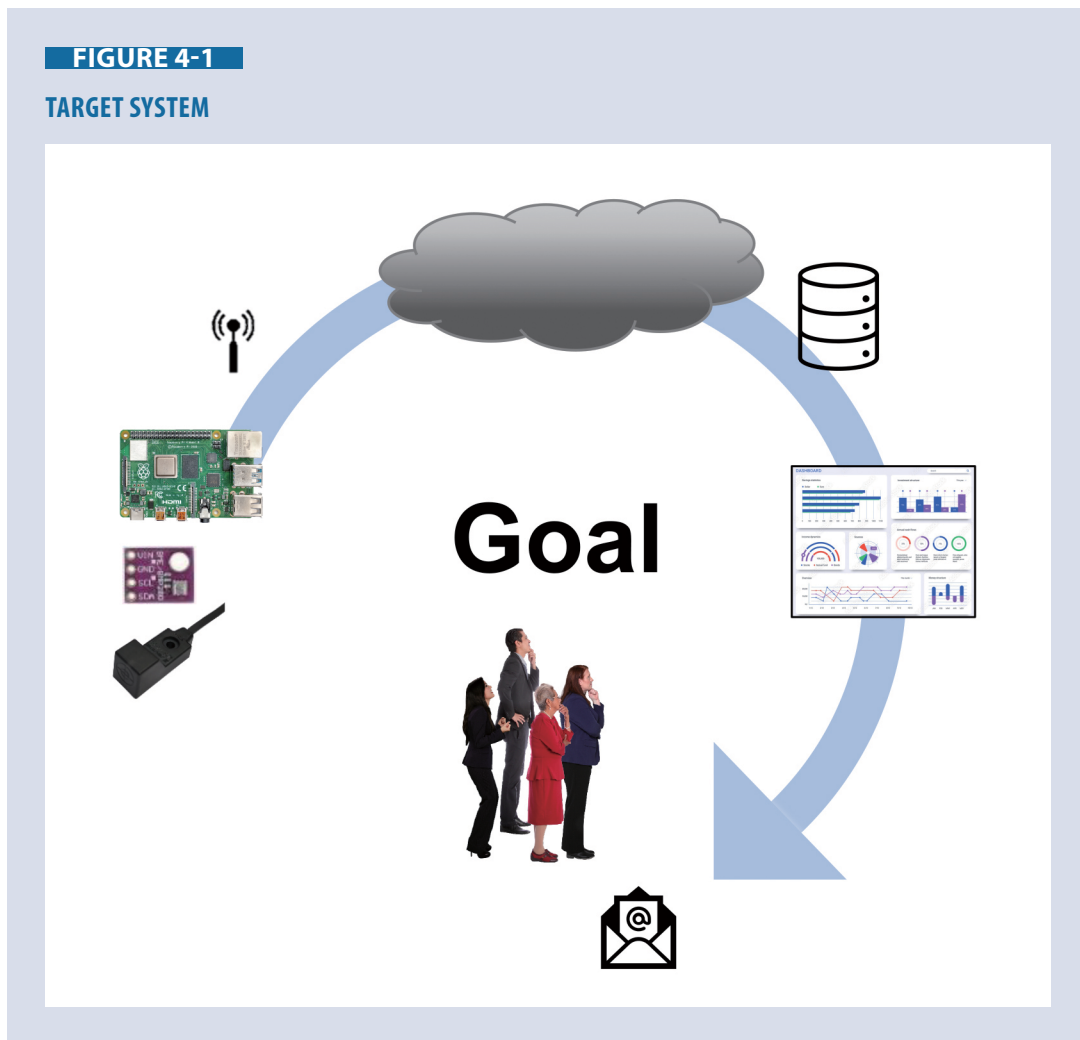

## Chapter 4.1 Building the Raspberry Pi Development Environment

✓ In this Chapter, we will learn about the following.

- 4.1.1 What is the Raspberry Pi?
- 4.1.2 Raspberry Pi Family
- 4.1.3 Raspberry Pi board configuration
- 4.1.4 Raspberry Pi Software Development
- 
- 4.1.5 Initial Settings of the Raspberry Pi
- 4.1.6 VNC setup and activation
- 4.1.7 Using Visual Studio Code
- 4.1.8 Python Programming for Beginners



"Raspberry Pi" is  
NOT a Pie.

### 4.1.1 What is the Raspberry Pi?

**FIGURE 4-2**

**RASPERRY PI 4 MODEL B**

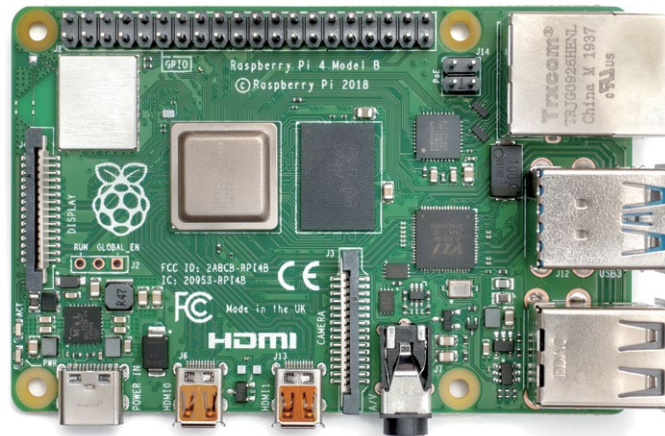

The Raspberry Pi is a palm-sized computer developed by the Raspberry Pi Foundation in the UK. The foundation hoped the computer would be used for IT education. Because it was inexpensive, compact, and easy to connect to sensors and actuators, many people who wanted a handy computer for home or work jumped on it. It has been a huge hit, selling a total of 50 million sets to date!

In a nutshell, the Raspberry Pi can be described as a small, inexpensive computer with many useful interfaces for connecting sensors and actuators. However, it is often used embedded in other devices rather than for stand-alone use like a Windows PC or Mac, and such computers are sometimes referred to as “microcontrollers.” [70]

### 4.1.2 Raspberry Pi Family

Since the original version of the Raspberry Pi was a huge hit, the Raspberry Pi Foundation has released many versions of the RPI in response to market demand.

The latest version of Raspberry Pi is “Raspberry Pi 5,” but this text uses the previous version, “Raspberry Pi 4 Model B.”

By the way, when the first Raspberry Pi was released, it cost only \$35. However, due to problems in the semiconductor supply chain and other issues, it will be around \$80 by the end of 2023.

Given that the Raspberry Pi is used for embedded applications, there is a strong demand for smaller and cheaper models. Therefore, the Foundation has also released inexpensive models such as Zero.

Pico was launched in 2021 during the pandemic. Pico is low-priced at around \$10, but it cannot have a general-purpose OS like Linux installed and is usually used without an OS. So, this model may be a hurdle for beginners who only know Windows PCs.

The following is a list of Raspberry Pi models. (Figure 3)  
(This is not a list of all Raspberry PIs)

**FIGURE 4-3**

**RASPBERRY PI FAMILY [70]**

Model	Release	CPU	GPU	Memory	USB	GPIO	Power	Network
1 Model B	2012/2	ARM1176JZF-S single core 700M Hz	250 MHz	256 MB/ 512 MB	2	26 pin	1.2 A	LAN
1 Model B+	2014/7	ARM1176JZF-S single core 700M Hz	400 MHz	512 MB	4	40 pin	1.8 A	LAN
2 Model B	2015/2	ARM Cortex-A7 quad core 900 MHz	400 MHz	1 GB	4	40 pin	1.8 A	LAN
3 Model B	2016/2	ARM Cortex-A53 quad core 1.2G Hz	400 MHz	1 GB	4	40 pin	2.5 A	LAN/Wi-Fi/ Bluetooth
3 Model B+	2018/3	ARM Cortex-A53 quad core 1.4G Hz	400 MHz	1 GB	4	40 pin	2.5 A	LAN/Wi-Fi/ Bluetooth
<b>4 Model B</b>	<b>2019/6</b>	<b>ARM Cortex-A72 quad core 1.5G Hz</b>	<b>Dual Core 500 MHz</b>	<b>1 GB/ 2 GB/ 4 GB/ 8 GB</b>	<b>4</b>	<b>40 pin</b>	<b>3.0 A</b>	<b>LAN/Wi-Fi/ Bluetooth</b>
Zero	2015/11	ARM1176JFZ-S single core 1G Hz	250 MHz	512 MB	1	40 pin	1.2 A	—
Zero W/WH	2017/2	ARM1176JFZ-S single core 1G Hz	250 MHz	512 MB	1	40 pin	1.2 A	Wi-Fi/ Bluetooth
Pico	2021/2	ARM Cortex-M0 dual core 133M Hz	-	2 MB	1	40 pin	1.8- 5.5 V DC	—



All of these models are Model B. In addition, there is a Model A. Model B is 2 cm smaller in width and almost square in shape. Model A consumes less power than Model B but has fewer USB ports, memory, and other specifications than Model B.

There is also a special Model called the Compute Module. This does not have many interfaces, is designed to be built into a custom board, and is suitable for industrial use.

#### 4.1.3 Raspberry Pi board configuration

Figure 4 shows the Raspberry Pi 4 Model B board. You can see that many interfaces are compactly implemented.

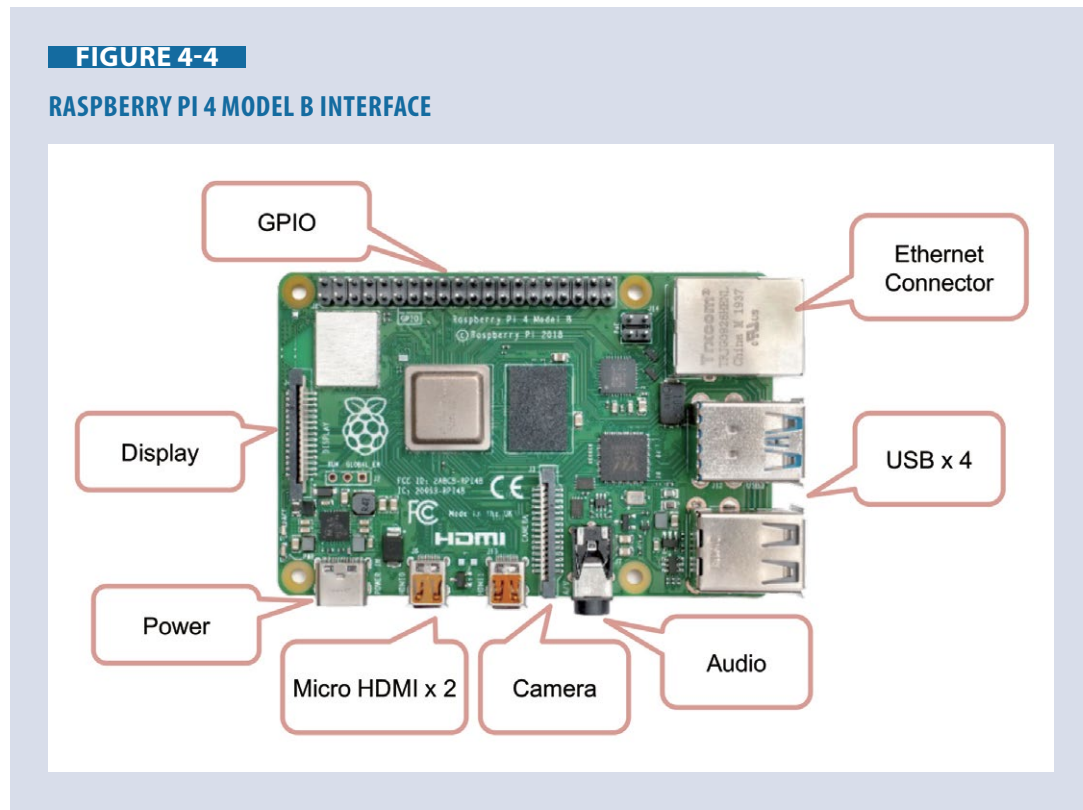

Here is an overview of the functions of each interface.

- GPIO stands for general purpose input/output. It consists of several input/output pins. The GPIO of the Raspberry Pi 4 Model B consists of 40 pins. It is used to input signals from the outside and output signals to the outside. For example, connect sensors, LEDs, buttons, motors, etc. [71]
- The connector for the display is a video output with a specification called DSI (Display Serial Interface), which is mainly used to connect an embedded touch panel.
- The power connector is connected to a 5 V DC power supply. The Raspberry Pi 4 Model B uses a USB-Type C connector, which can carry up to 3 A of current. Therefore, the adapter that powers it must be capable of supplying at least 3 A of current.<sup>1</sup>

<sup>1</sup> The voltage (V) requires an adapter rated at 5 V, and the current (A) requires an adapter rated at 3 A or higher; insufficient current will result in damage to the adapter or a flame.



- The Micro HDMI connector connects a display that supports HDMI (High-Definition Multimedia Interface). You can connect a full HD (1920x1080) display. The Raspberry Pi 4 Model B has two ports, so connecting a main display and a sub-display is convenient for software development.
- The camera connector connects an embedded camera specifically designed for the Raspberry Pi.
- The audio connector is a 3.5mm audio jack connecting speakers or headphones.
- The USB connector can connect various devices such as cameras, displays, mice, keyboards, etc. The Raspberry Pi 4 Model B has two USB 2.0 and two USB 3.0 connectors.
- The ethernet connector is a connector for connecting to a wired LAN. It is used when a faster and more stable connection than a wireless LAN is required.

Figure 5 shows the boards for the other models. Zero and Pico are much smaller to facilitate integration into other devices.

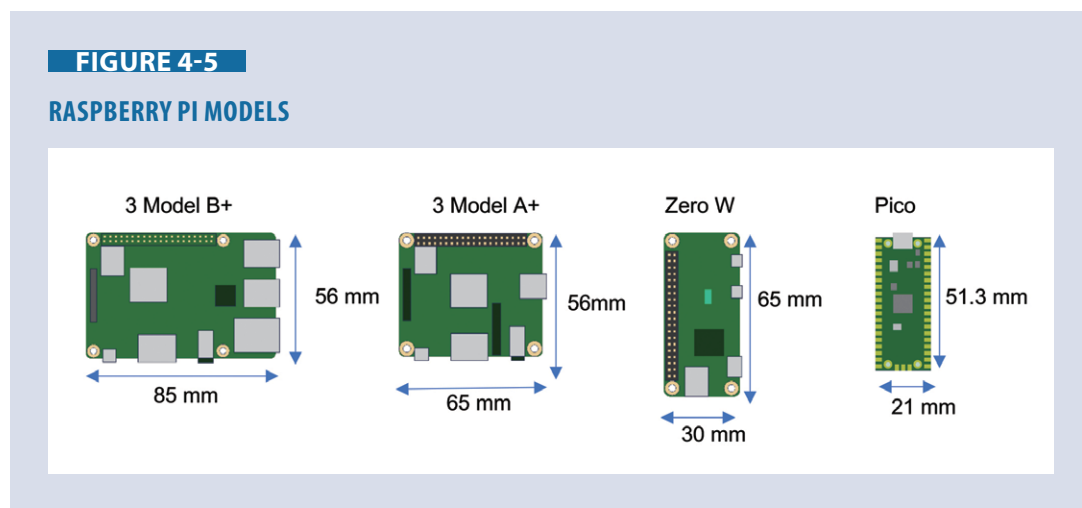

#### 4.1.4 Raspberry Pi Software Development

The Raspberry Pi comes standard with a Linux-based operating system called “Raspberry Pi OS.” This means that most of the operations can be performed via GUI,<sup>2</sup> and it can also be used as a normal desktop computer.

<sup>2</sup> A GUI (graphical user interface) allows the user to visually view the commands and instructions given to the computer on the screen and input them using a mouse, etc. Compared to CLI (command line interface), which executes commands by keystrokes, GUI is characterized by its intuitive operation.

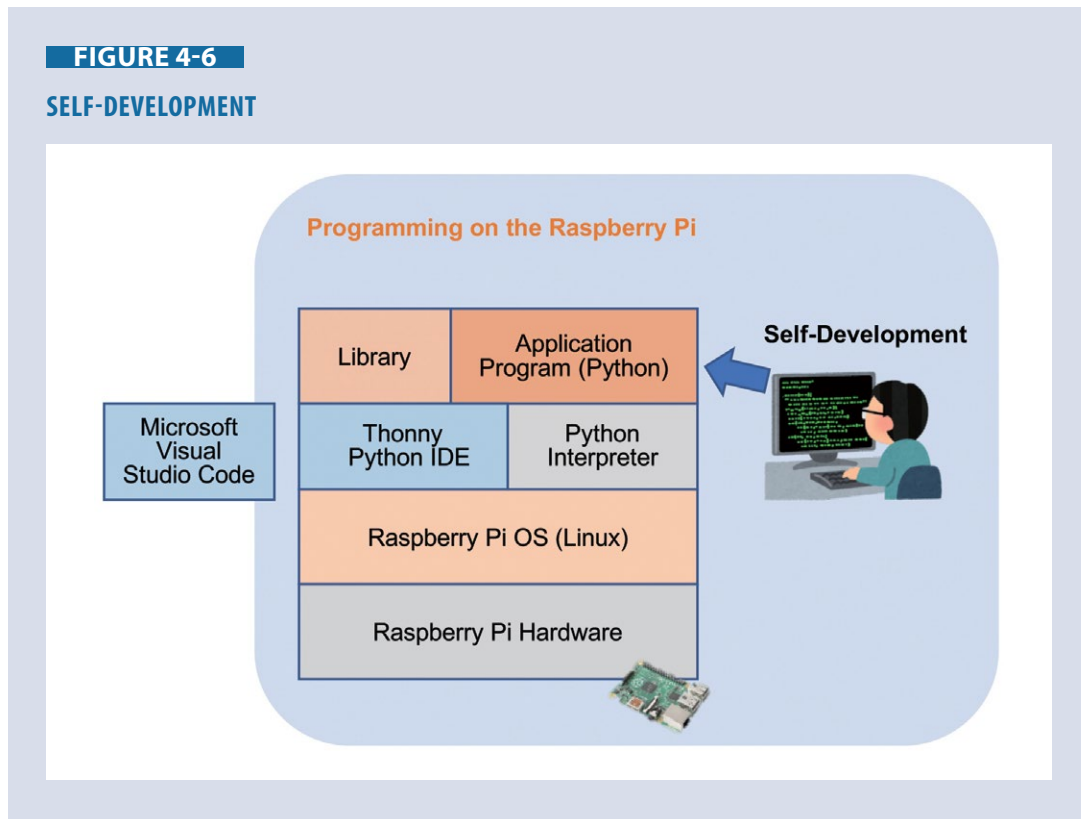
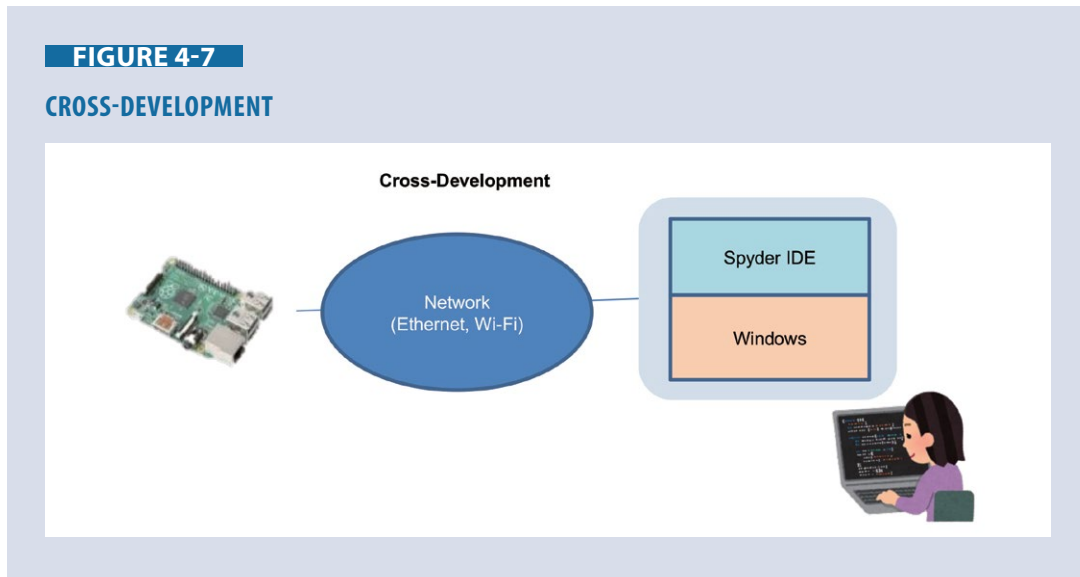

Figure 6 shows the software configuration of the Raspberry Pi. On top of the Raspberry Pi OS is the Python language processor and Python IDEs such as Thonny and Visual Studio Code. Programmers use these to develop application programs in Python. Depending on the contents of the program, related libraries (packages) must be installed.

Since all the necessary tools can be installed on the Raspberry Pi OS, programs can be developed independently without the need to connect an external PC. This type of development, where the execution and development machines are the same, is called “self-development.”

On the other hand, lower-priced, smaller microcontrollers such as the Raspberry Pi Zero and Arduino have less memory and do not have an OS. In this case, the program is developed, and bugs are fixed on an external PC. The program’s executable code is transferred from the external PC to the microcontroller for execution. This type of development is called “cross-development” and is contrasted with the self-development described above. (Figure 7)

**FIGURE 4-7**  
**CROSS-DEVELOPMENT**



#### 4.1.5 Initial Settings of the Raspberry Pi

##### (1) Making an OS image of the Raspberry Pi (on a MicroSD card)

First, you need to create a MicroSD with the Raspberry Pi OS written on it. For this purpose, using an app, Imager, provided by the Raspberry Pi Foundation, is common.

Please refer to the following URL to create a microSD card for installation.

<https://www.raspberrypi.com/software/>

While creating a microSD card with Imager, please configure the username, password, Wi-Fi settings, etc. These settings can be done later, but it is easier to do so in Imager.

##### (2) Inserting MicroSD card (OS included)

Let's insert the microSD card we created earlier into the RPI.

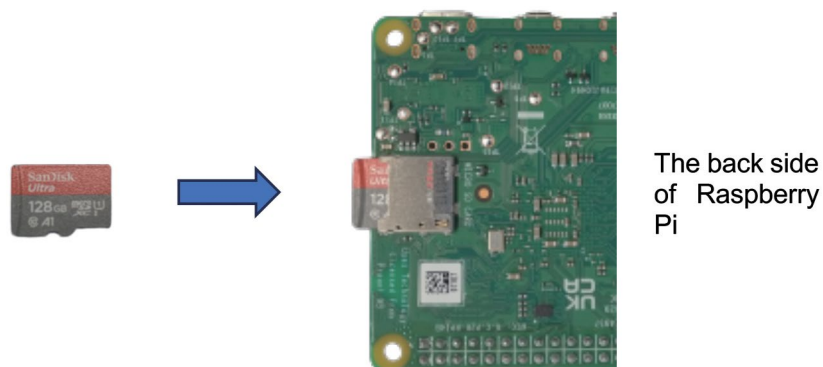

##### (3) Connecting peripherals

Connect power, display, mouse, and keyboard to your Raspberry Pi. The display is connected to the HDMI connector, and the mouse and keyboard are connected to the USB connector. Do not turn on the power yet.

**FIGURE 4-8**  
**CONNECTING PERIPHERALS**

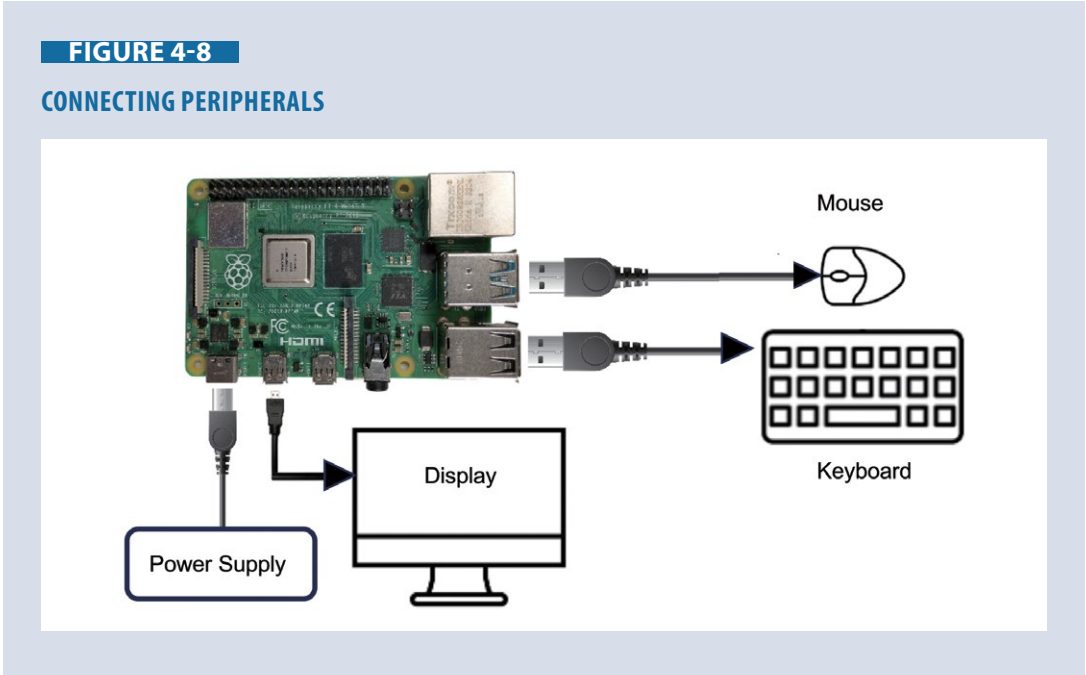

**(4) Power on**

When you first power on the Raspberry Pi, the screen that appears will differ depending on how the Imager creates the MicroSD card.

If a MicroSD card is created with the default settings in Imager (no username, password, Wi-Fi, etc. settings), the following screen will appear and prompt you to set parameters. Please follow the on-screen guidance to set the username, password, and Wi-Fi settings, then restart.



On the other hand, if the necessary settings have been completed in Imager, the desktop screen shown below appears immediately.

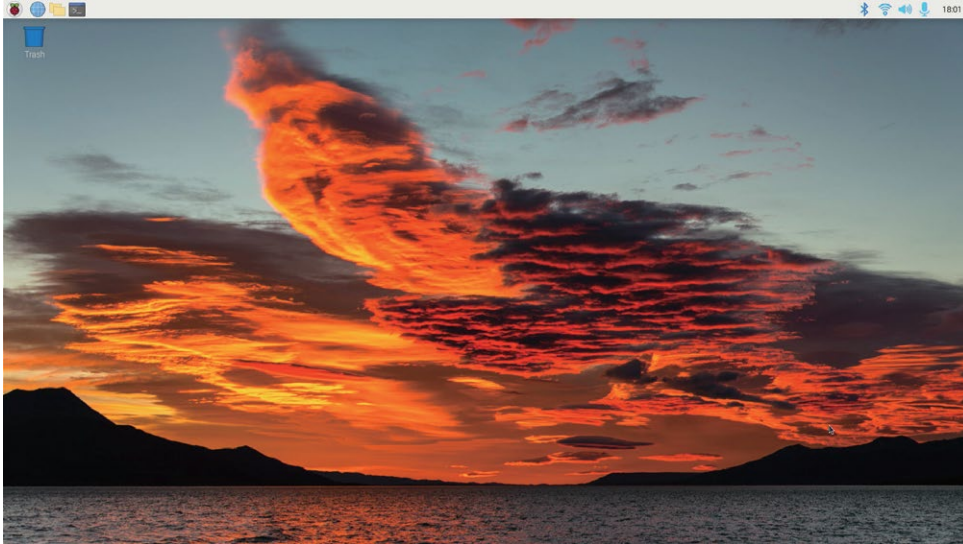

### (5) Shutdown

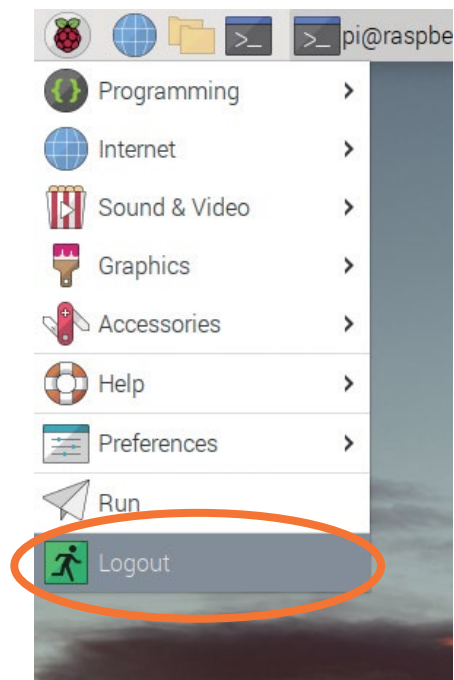

Since the Raspberry Pi is a computer, you must learn how to turn it off, or you might damage the OS.

To turn off the power, you must first shut down the system. Click on the raspberry icon in the upper-left corner and select “Logout” from the list below.

Select “Shutdown” from the dialog box that appears. (Do not turn off the power switch immediately after this)

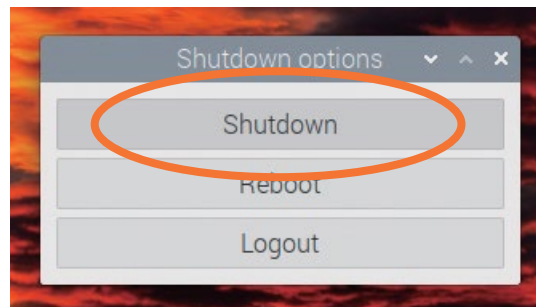

### (6) Turn off the power

The blue LED flashes when the shutdown is performed. This indicates that the microSD card is being accessed. Do not turn off the power while the blue LED is flashing.

When the blue LED stops flashing, turn off the power switch.

#### 4.1.6 VNC setup and activation

##### (1) What is VNC?

Virtual network computing (VNC) is the software that allows a remote computer's desktop to be displayed on the screen of the computer at hand and controlled from a distance via a network. This type of functionality is generally referred to as remote desktop. (Figure 9)

VNC not only makes program development easier but also allows development to be done using only the PC, without the display, mouse, and keyboard on the Raspberry Pi side.

The Raspberry Pi OS has VNC installed from the start, but it must be enabled from the configuration screen, as we will explain later.

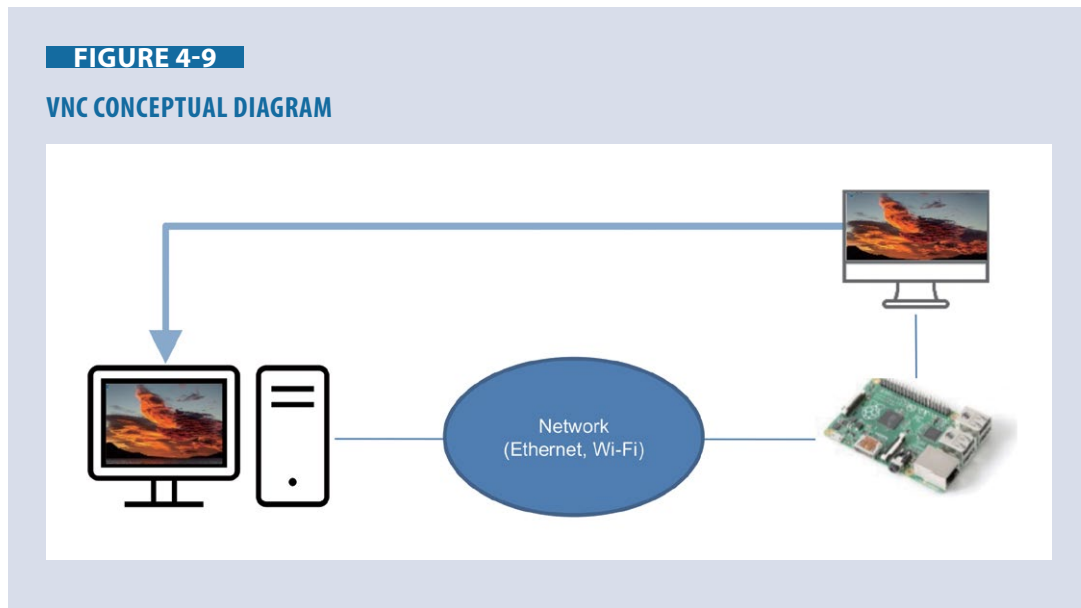

**(2) Enable VNC and SSH on the Raspberry Pi side.**

If you turned off your Raspberry Pi in the previous section, please turn it on again.

Click on the menu icon in the upper-left corner, hover over “Preferences” in the menu, and select “Raspberry Pi Configuration” from the menu that appears.

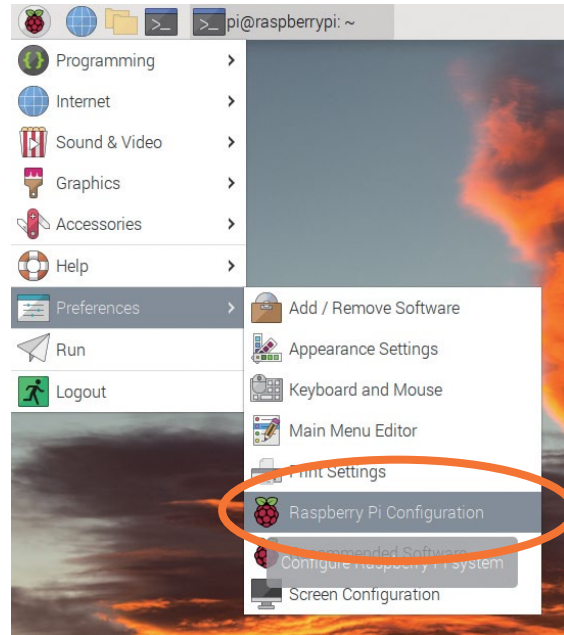

The “Raspberry Pi Configuration” dialog box will appear. Turn on “SSH” and “VNC” and press the “OK” button.

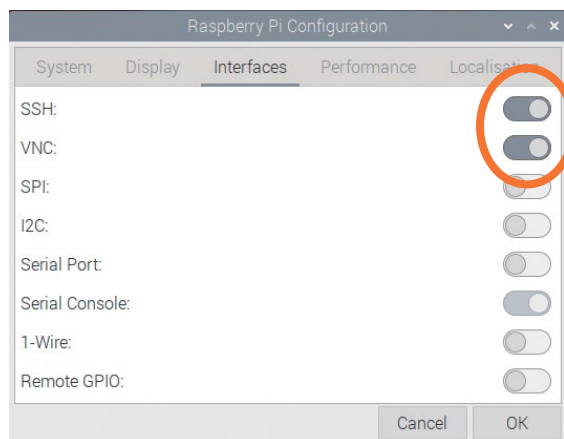

A VNC icon appears in the upper-right corner of the screen, indicating that VNC is operational.

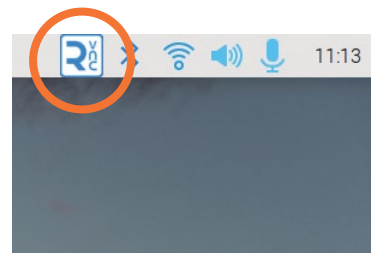



**(3) Install VNC Viewer on the PC side**

On the PC side, a program called VNC Viewer must be installed. VNC Viewer can be installed on Windows, Mac, etc. Here, we will explain how to install it on Windows. Edge is used as the browser.

First, access the following URL.

<https://www.realvnc.com/en/connect/download/viewer/>

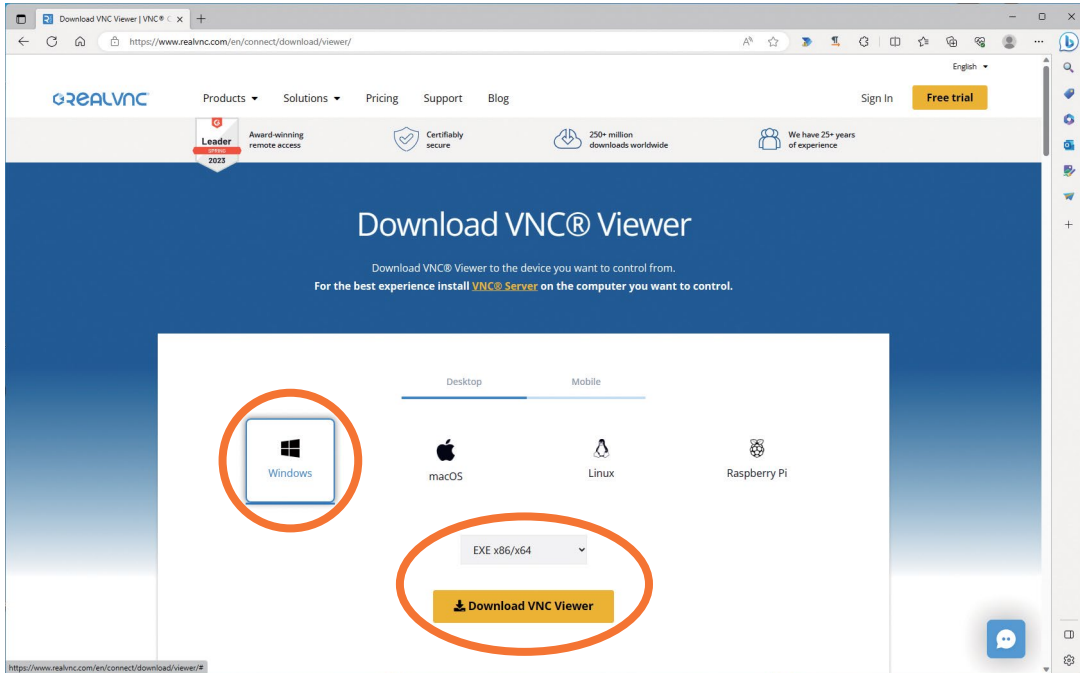

Make sure “Windows” and “EXE x86/x64” are selected and click “Download VNC Viewer.” The download will begin.

**Source:** The image taken by the author using the service of RealVNC<sup>®</sup> Limited. [72]

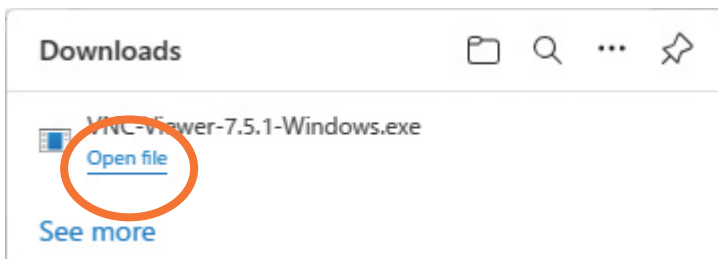

In Edge, a dialog box will appear in the upper-right corner to inform you that the download is finished. Click “Open file.”

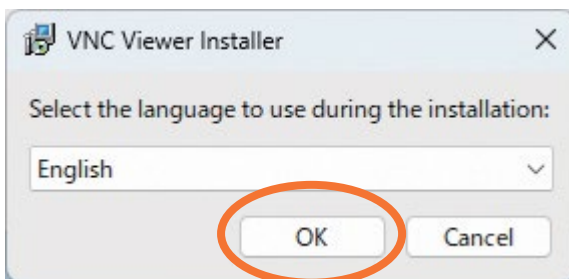

Select the language used for installation, in this case, “English,” and press the “OK” button.



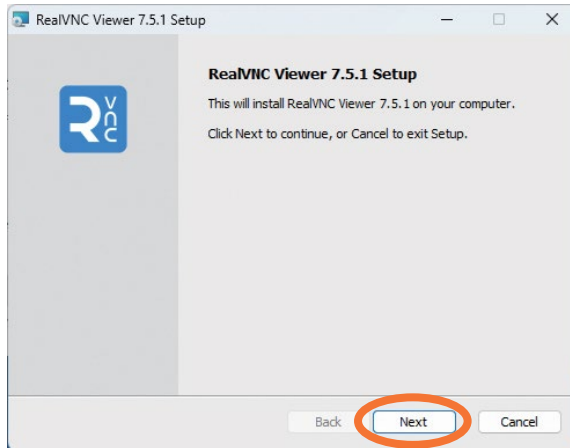

The setup wizard will start.  
Click “Next” to continue.

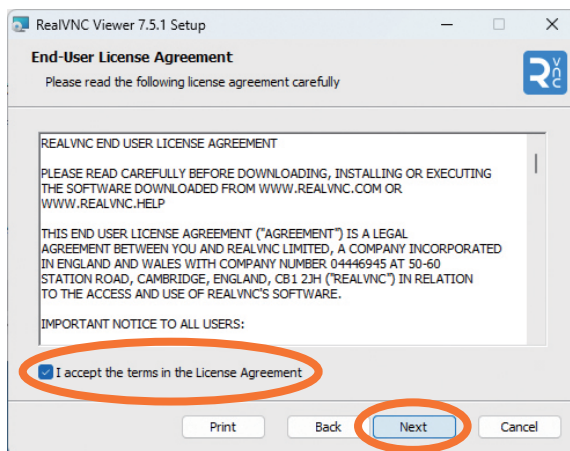

When the license agreement screen appears,  
check “I accept the terms in the License  
Agreement” and press the “Next” button.

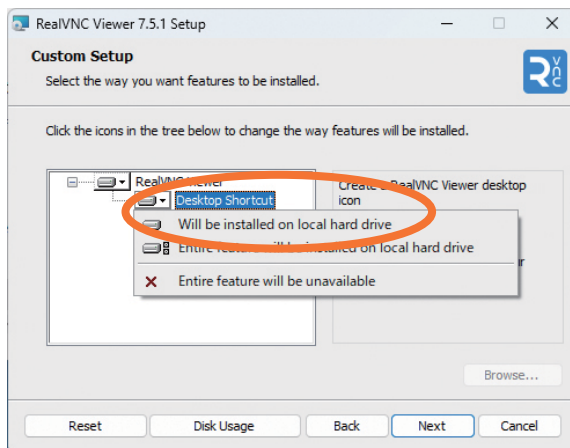

When the “Custom Setup” screen appears,  
click the button to the left of “Desktop  
Setup” to open the list, select “Will be  
installed on local hard drive” and press the  
“Next” button.

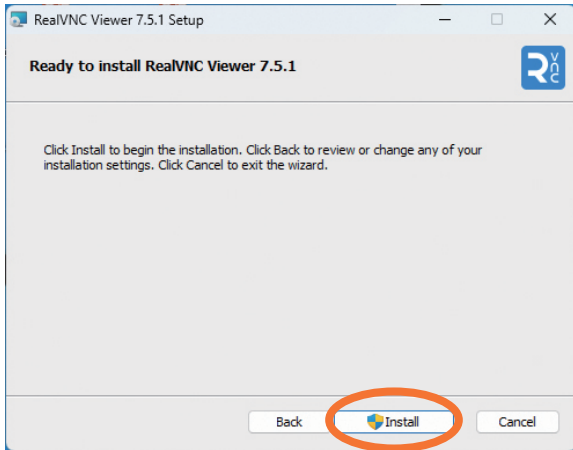

When the “Ready to install RealVNC Viewer” dialog box appears, press the “Install” button.

After this, if the “User Account Control” screen appears and the message “Do you want to allow this application to make changes to your device?” appears on it, press the “Yes” button.

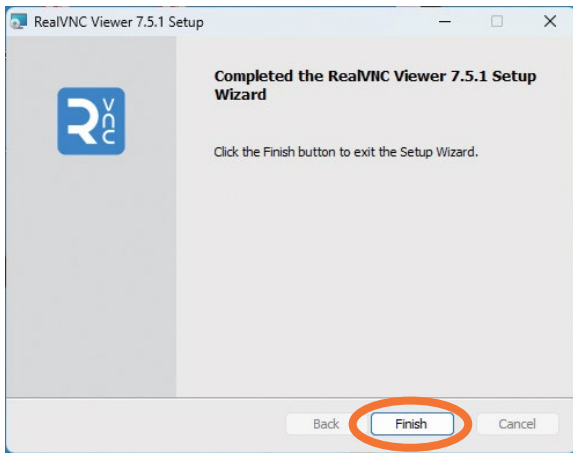

When the installation is finished, the dialog box on the left will appear. Click “Finish” to exit.

#### (4) Connecting VNC Viewer to the Raspberry Pi

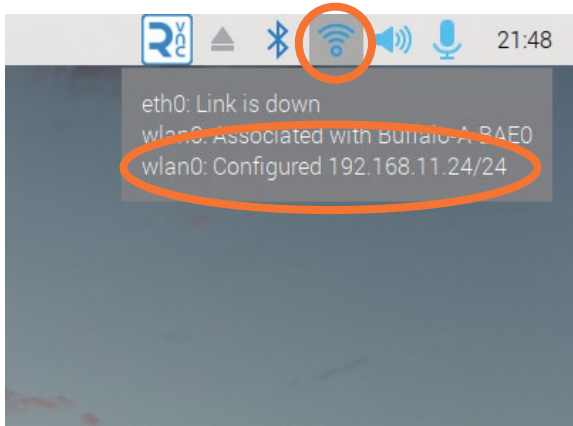

First, check the IP address of the Raspberry Pi.

Hover your mouse over the Wi-Fi icon in the upper-right corner of the Raspberry Pi desktop to see the IP address.

In this example, the IP address of the Raspberry Pi is 192.168.11.24.



Next, return to your Windows PC and double-click the RealVNC icon on the desktop to launch the Viewer.

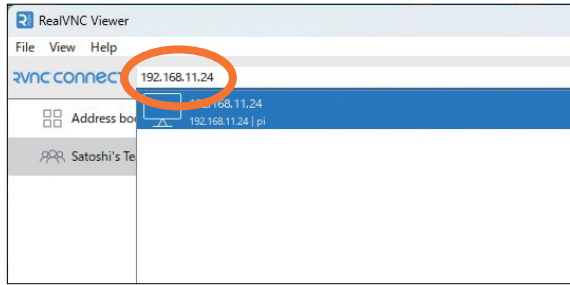

Enter the IP address of the Raspberry Pi in the text box at the top of the dialog box and press “Enter” on the keyboard.

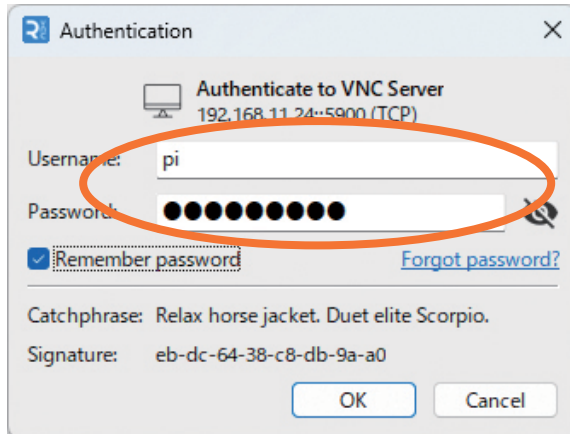

Enter your Raspberry Pi username and password and press the “OK” button.

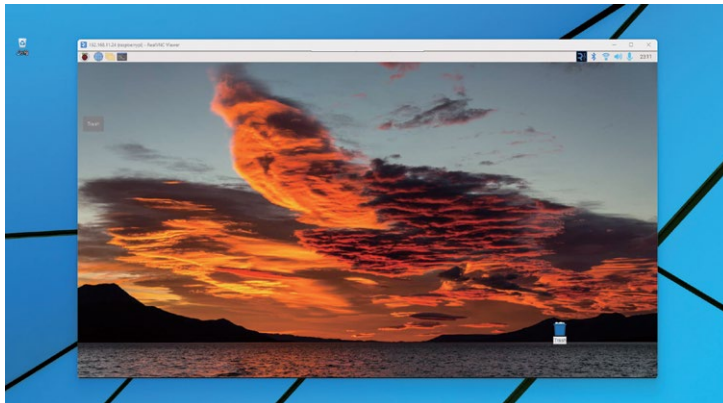

The Raspberry Pi desktop will appear inside the Windows desktop.

You can operate the mouse and keyboard on the Raspberry Pi desktop.

#### 4.1.7 Using Visual Studio Code

##### (1) What is Visual Studio Code? [73]

Thonny is a pre-installed Python development environment that can be used on the Raspberry Pi.

However, we recommend using Microsoft’s Visual Studio Code (VSCode). VSCode is highly functional, and its IntelliSense feature, which assists with input, is easy to use and can increase productivity in program development. If you sign up with GitHub, you can also use the AI feature called Copilot.

You should note that VSCode uses a lot of memory, so it will not work on the Raspberry Pi Zero.

## (2) Installation of Visual Studio Code on the Raspberry Pi

There are two ways to install VSCode: from the command line or the GUI. The method using the GUI is described here.

### STEP 1

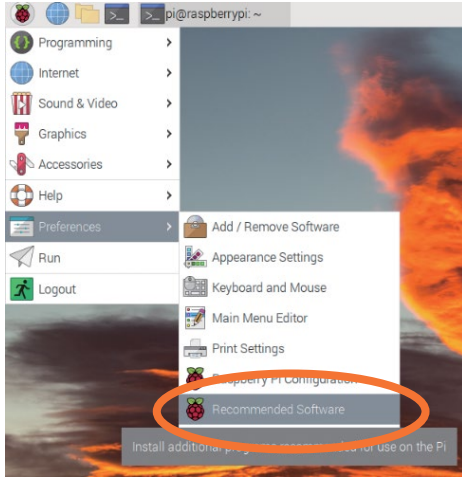

Click on the raspberry icon in the upper-left corner and hover over “Preferences” to bring up a list. Select “Recommended Software” from the list.

### STEP 2

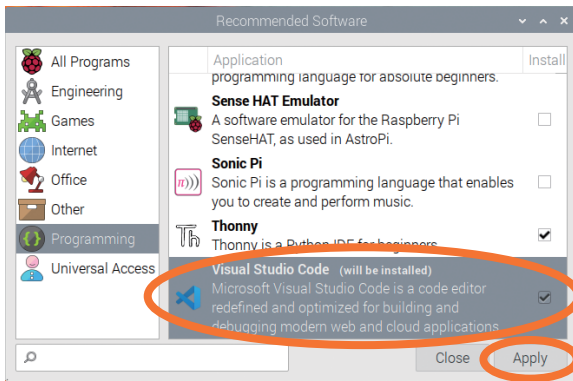

In the “Recommended Software” dialog box, select “Programming” from the left pane, scroll down the right pane, and select “Visual Studio Code”.

Press the “Apply” button to start the installation.

### STEP 3

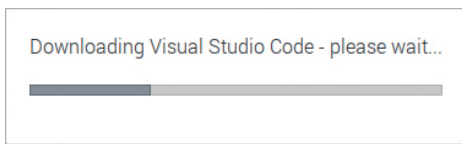

The download will begin, and after a short time, the installation will be completed.

Press “OK” to close the dialog box.

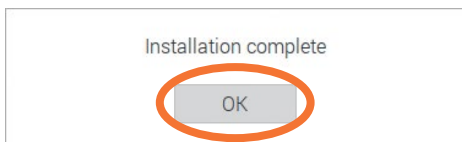

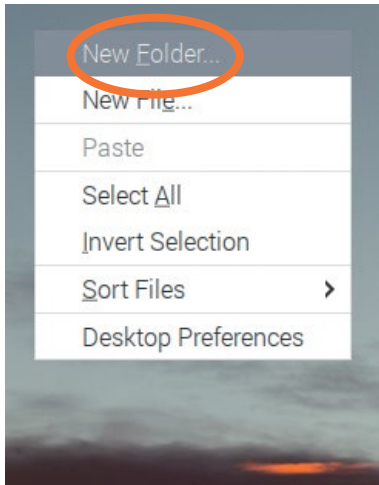
**(3) Python programming with Visual Studio Code****STEP 1: Create a Test Folder**

First, create a folder to store Python programs.

Place the cursor on the appropriate location on the desktop and right-click. A dialog box like the one on the left will appear.

Select “New Folder”.

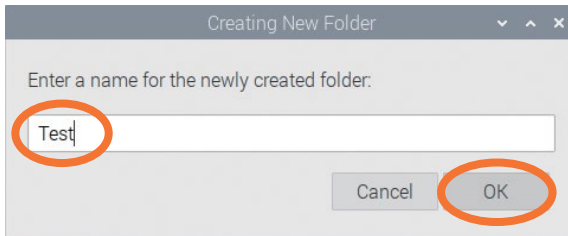

Enter a name for the folder and press the “OK” button.

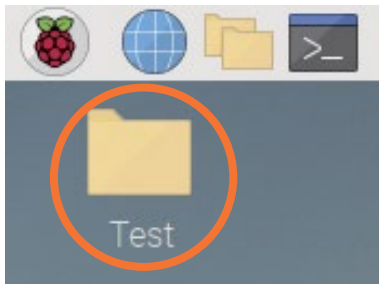

A folder is created on the desktop.

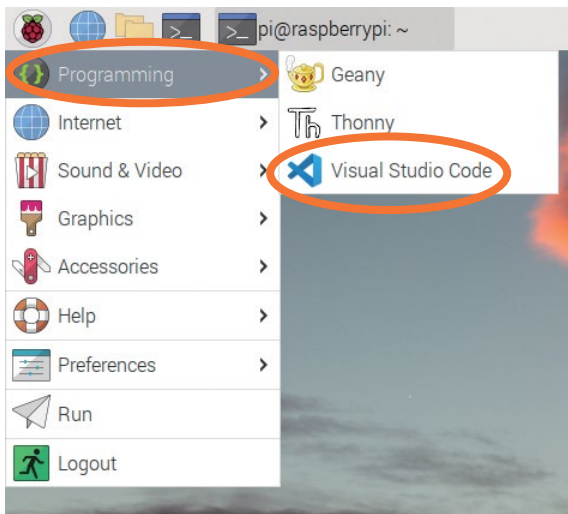
**STEP 2: Start VS Code**

Next, we will start VSCode.

Click on the raspberry icon in the upperleft corner of the screen and hover the cursor over “Programming” to bring up a list. Select “Visual Studio Code” from the list to start VSCode.

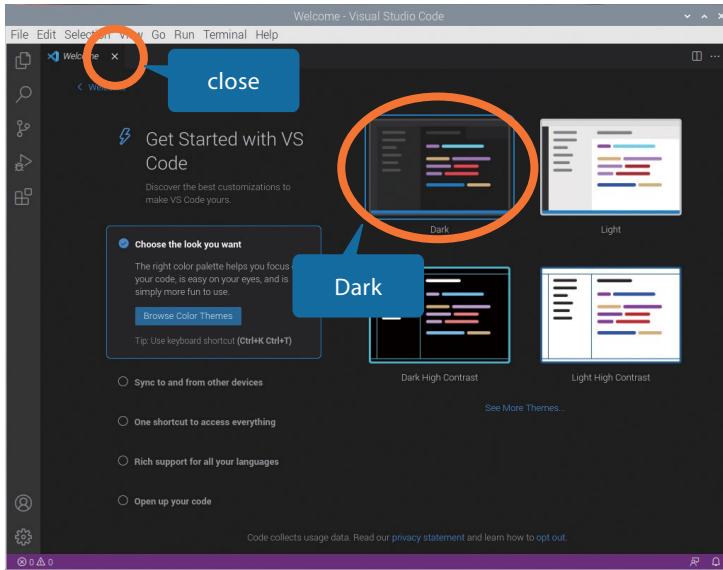

When you first start VS Code, you will be asked how you want to design your screen.

At first, click on the default “Dark,” then click on the x button at the top to turn off this screen.

**STEP 3: Create files for Python and install Python.**

While VSCode is installed, Python has not yet been installed. You will be prompted to install Python when you first create a file for Python.

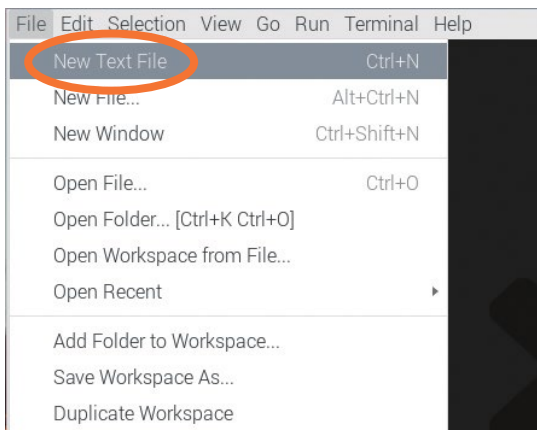

First, select “New Text File” from the “File” menu in the upper-left corner of the dialog box.

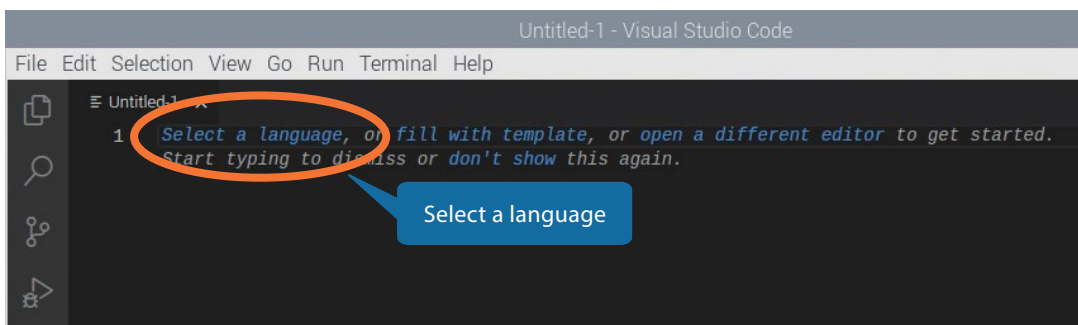

Click on “Select a language”.

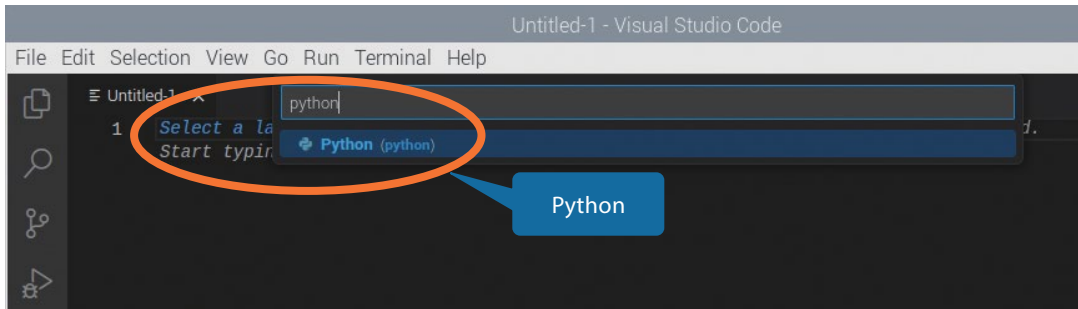

A list of available languages will appear. Select the Python language by typing “Python” in the top text box.

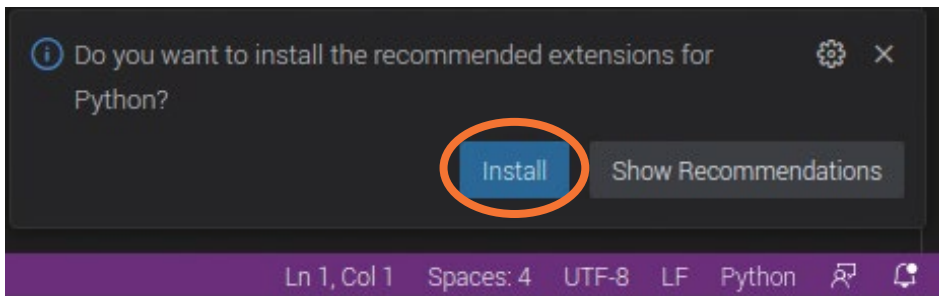

Since Python is not yet installed, the message “Do you want to install the recommended extensions for Python?” will appear in the lower-right corner of the dialog box. Press the “Install” button. If Python is already installed, this message will not appear.

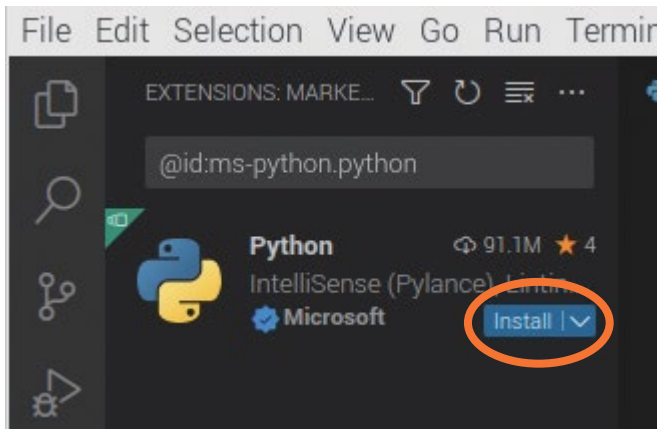

The extension “Python IntelliSense” will appear in the upper-left corner of the dialog box.



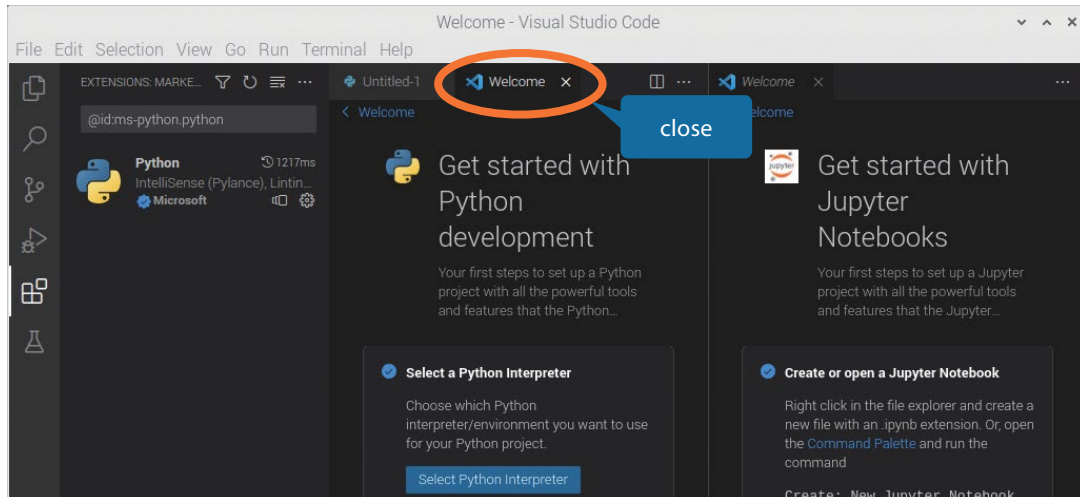

After the installation is complete, the “Welcome” page will appear. If you have more than one Python interpreter installed, you can select one here. For now, simply click the “X” button to close it.

**STEP 4: Create and run your first Python program**

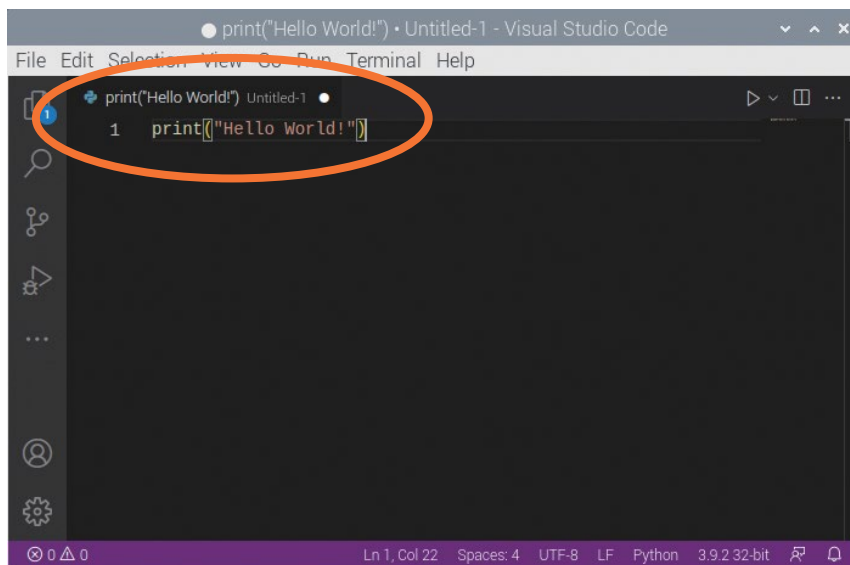

Now, let’s write a program in the file “Untitled-1” that we just created. Using the keyboard, type print (“Hello World!”).

This program simply outputs the string “Hello World!” to the console.



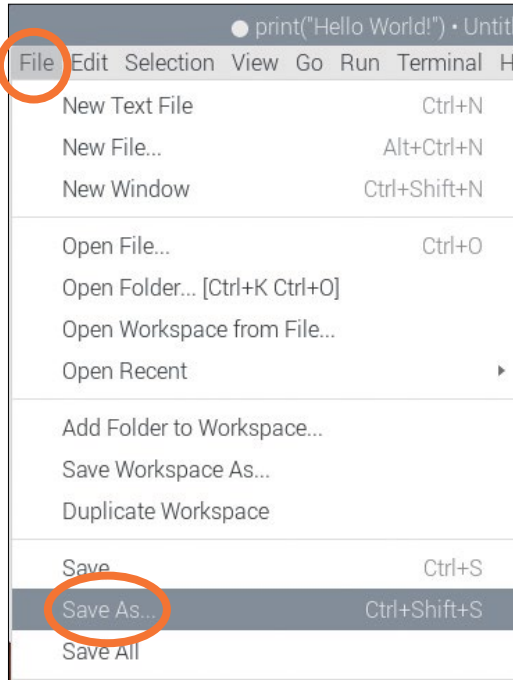

Save this file first before running the program.

From the menu, select “File”, then “Save As...”.

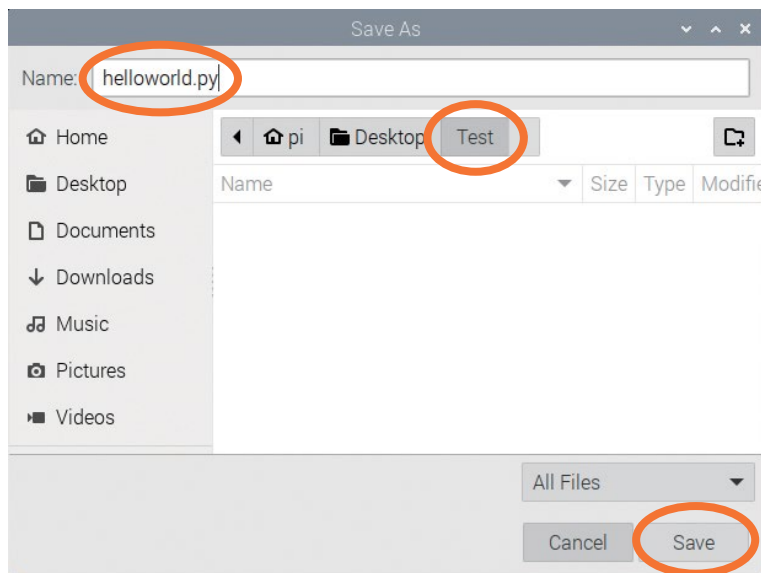

The “Save As” dialog opens. Name the file “helloworld.py.”

Check the folder “Test” and press the “Save” button.

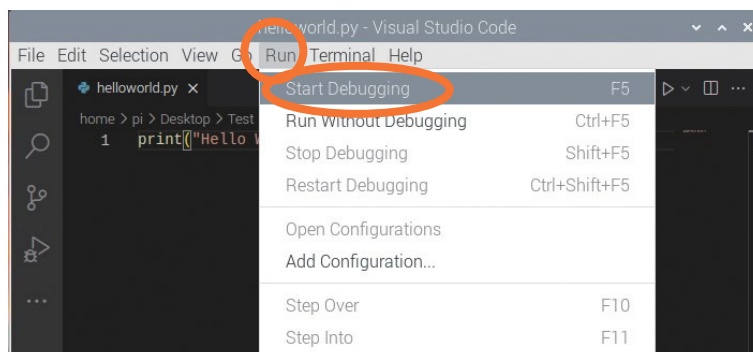

Now, let’s run the program.

From the menu, select “Run” and then “Start Debugging”.

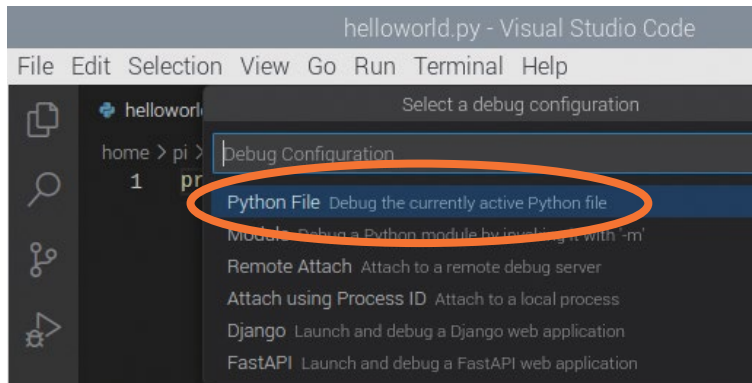

The first time you debug, you will be asked for “Debug Configuration”.

Select “Python File”. Then, the program will be executed.

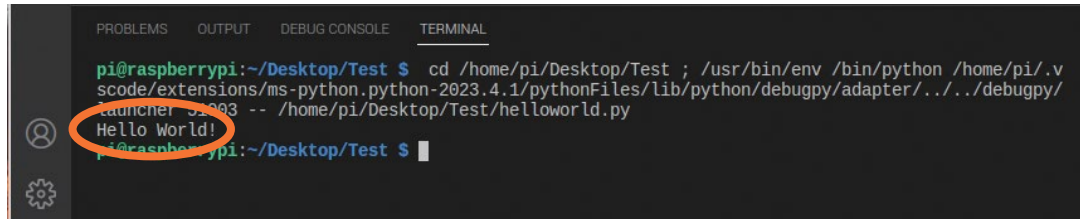

The result is displayed in the terminal window at the bottom, along with the commands you entered. You can see the string “Hello World!” in the terminal window.

#### 4.1.8 Python Programming for Beginners

Here, we will learn the basics of Python programming.

##### (1) Variables, loops, blocks, and comments

**FIGURE 4-10**

##### EVENS.PY

```

1  # Description: This program will print the even numbers from 2 to 100
2
3  # Initialize the variable n to 0
4  n = 0
5
6  # While n is less than or equal to 100, do the following
7  while n <= 100:
8      n = n + 1; # Increment n by 1
9      if ((n % 2) == 0): # If the remainder of n divided by 2 is 0, then n is even
10         print(n)

```

Now, let’s take a look at the Evens.py program in Figure 10.

This program prints even numbers between 2 and 100 to the console.

First, comments in Python are marked with #. From # to the end of the line is considered a comment. In VSCode’s default configuration, comments are displayed in green.

In this program, the first line is a comment about what the program does.

The fourth line defines the variable `n` and sets its initial value to 0.

In Python, there is no need to declare variables expressly. Even if you do not specify the variable type (integer, decimal number, etc.), the type will be determined automatically depending on the context.

Line 7 uses a while statement to repeatedly execute the block below it while `n` is less than or equal to 100.

One of the features of Python is that indentations represent blocks. In other programs, you use BEGIN and END or brackets, but in Python, a set of lines with the same indentation is considered a block.

In this program, lines 8 and 9 are considered one block because they have the same indentation.

In line 8, the variable `n` is incremented by 1. Each time the loop goes through, `n` increases by 1, and when it exceeds 100, the loop ends.

Now, let's run VSCode by selecting "Run" from the VSCode menu and then selecting "Start Debugging". You can also use the F5 function key.

```
84
86
88
90
92
94
96
98
100
```

It is successful if the VSCode terminal window displays even numbers from 2 to 100.

In the screen on the left, only the later numbers are visible.

**(2) Breakpoints and debugging controls**

When developing a program, you often want to stop it at a particular place. When a program behaves strangely, you have to find out where the problem is. If you set a breakpoint at a position you suspect, VSCode will pause the program there.

Let's take a look at this feature below.

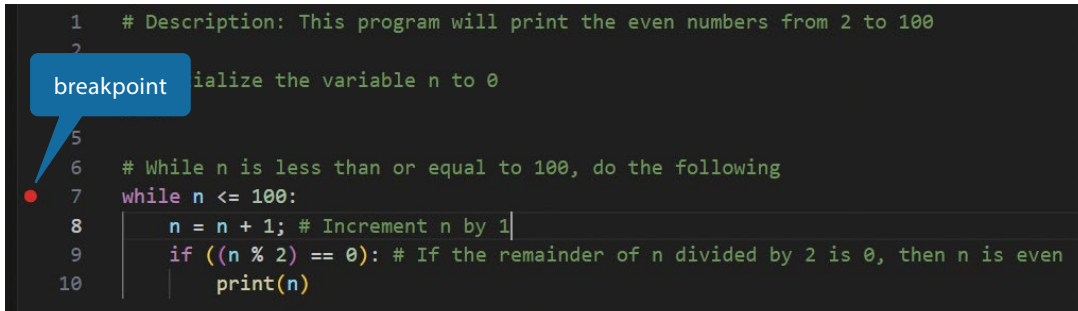
**STEP 1: Set a breakpoint**

```

1 # Description: This program will print the even numbers from 2 to 100
2
3 initialize the variable n to 0
4
5
6 # While n is less than or equal to 100, do the following
7 while n <= 100:
8     n = n + 1; # Increment n by 1
9     if ((n % 2) == 0): # If the remainder of n divided by 2 is 0, then n is even
10        print(n)

```

Move the cursor to the left of the line number and click to display a red circle. This indicates that a breakpoint has been set on this line. Click again to cancel.

**STEP 2: Start debugging**

Now, go to “Run” and “Start Debugging” from the menu. (You can also press F5)

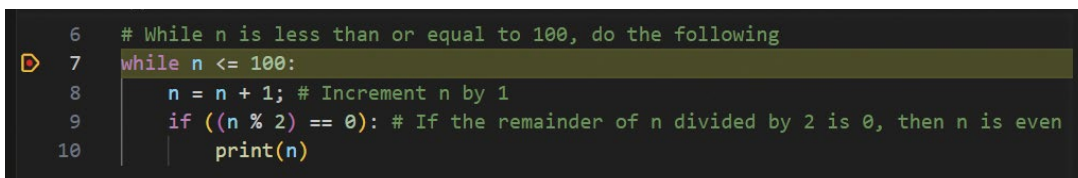

```

6 # While n is less than or equal to 100, do the following
7 while n <= 100:
8     n = n + 1; # Increment n by 1
9     if ((n % 2) == 0): # If the remainder of n divided by 2 is 0, then n is even
10        print(n)

```

The program is executed and stops before line 7. The seventh line has not yet been executed.

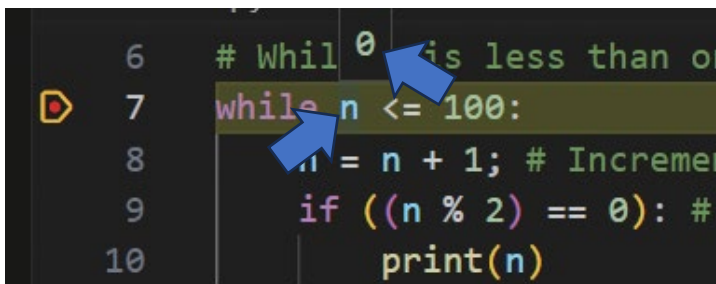
**STEP 3: View variable values**

```

6 # While n is less than or equal to 100, do the following
7 while n <= 100:
8     n = n + 1; # Increment n by 1
9     if ((n % 2) == 0): #
10        print(n)

```

Moving the cursor over the variable `n` displays the current value 0 of `n`.

The value of `n` was set to 0 at the beginning of the program, so you can see that it is working as expected.

**STEP 4: Control debugging**

When you start debugging, the Debug Control Panel appears at the top of the VSCode screen. This is used to control the debugging execution of the program.

- The leftmost “Continue” button continues execution from where it stopped.
- The next “Step Over” button executes only that line. If the line is a function, it will move to the next line without entering the function.
- The third “Step Into” button from the left, if the line is a function, goes into the function.
- The third “Stop Out” button from the right is for exiting the function.
- The second “Restart” button from the right restarts the program from the beginning.
- The rightmost button exits the program.

**(3) Functions****FIGURE 4-11****FUNCTION.PY**

```

Function.py > ...
1  # Description: Function example
2
3  def add(a, b): # a, b are parameters
4      return a + b # add a and b and return the result
5
6  result = add(1, 2) # 1, 2 are values of parameters passed to the function
7  print(result) # print the result

```

Functions allow you to group chunks of code into a single block that can be called from elsewhere.

Lines 3 and 4 of Function.py (Figure 11) define a function named “add”. To define a function, it must be prefixed with “def”. This function is very simple: it takes parameters a and b from the caller, calculates a + b, and returns the result to the caller.

Lines 3 and 4 only read the function definitions; they are not executed. The program starts at line 6.

In line 6, the function “add” is called with parameters 1 and 2. The function “add” adds 1 and 2, returns 3, and assigns it to “result.”

In line 7, the value of “result” is written to the console. In this case, “3” is displayed on the console.

In program development, it is often necessary to perform the same process many times. Instead of copying and pasting the code each time, it is important to put it into a function and call it.

**(4) Standard functions and imports**

Python has a standard library, which can be used as soon as Python is installed. Among them, built-in functions can be used without special declarations (imports). The “print” function used previously is an example of that built-in function.

In addition, some standard libraries cannot be used without import declarations. For example, to output the current Python version, the “sys” module must be imported.

```
1 import sys # import sys module
2
3 # print version of python
4 print(sys.version)
```

In an IoT project using the Raspberry Pi, it is necessary to handle GPIO (input/output interface) and sensors provided by various manufacturers. Since these are not standard Python libraries, you will need to install the relevant modules and import them into your program as required.

## Chapter 4.2 Visualization of Equipment Operating Conditions Using Sensors

✓ In this Chapter, we will learn about the following.

- 4.2.1 Importance of Visualization of Operating Conditions in Kaizen
- 4.2.2 Types of Sensors Used for Object Detection
- 4.2.3 Creating a Parts Counting System
- 4.2.4 Proximity Sensor MDS-F4-5V
- 4.3.5 Connecting the MDS-F4-5V to the Raspberry Pi
- 4.2.6 Python Programming of the Parts Counting System



### 4.2.1 Importance of Visualization of Operating Conditions in Kaizen

As explained in 2.2.1, production control is very important in kaizen. The first step in implementing kaizen in production control is to visualize the operating status of equipment. By acquiring and visualizing data that has not been available until now, many insights can be gained, leading to kaizen ideas.

The visualization method should be appropriate to the equipment’s type, function, and characteristics. Counting parts or machine movements is a common method. In this chapter, we will use a Raspberry Pi to create a system that simply counts the number of parts.

### 4.2.2 Types of Sensors Used for Object Detection

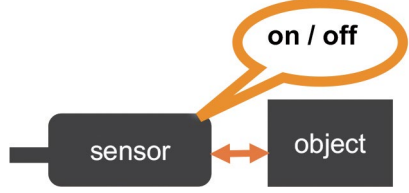
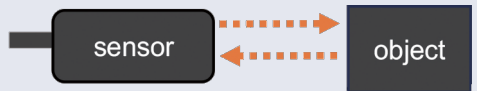
In many manufacturing processes, parts or semi-finished products are transported by conveyor belts, passing through several assembly and processing stations before gradually being finished. In such cases, various sensors are used to count the presence or absence of objects and the number of objects. Typical examples are shown below.

Type	Description
Proximity sensor	<p>A proximity sensor is a sensor that determines if an object has come within a short distance of the sensor. It judges the presence or absence of an object and cannot obtain the distance as a numerical value. The most common measuring principle is the use of magnetism. In this case, only metals can be detected.</p> 
Distance sensor	<p>A distance sensor is a sensor that measures the distance between an object and a sensor. Lasers, sound waves, etc., are used as the medium. Among distance sensors, those that measure the time it takes for the medium to hit the object and return are called ToF (time of flight) sensors.</p> 
Passage sensor	<p>A sensor that has an infrared emitter and receiver and detects when an object blocks light.</p> 

#### 4.2.3 Creating a Parts Counting System

In this example, a simple system is created by connecting a proximity sensor (MDS-F4-5V from Sensatech) to a Raspberry Pi and counting the number of times an object (metal) comes close to the sensor.

The proximity sensor is connected to the Raspberry Pi via GPIO. A Python program captures the change in voltage on the pin, counts the number of times it changes, and displays it on the terminal.

**FIGURE 4-12**  
**PARTS COUNTING SYSTEM CONFIGURATION DIAGRAM**

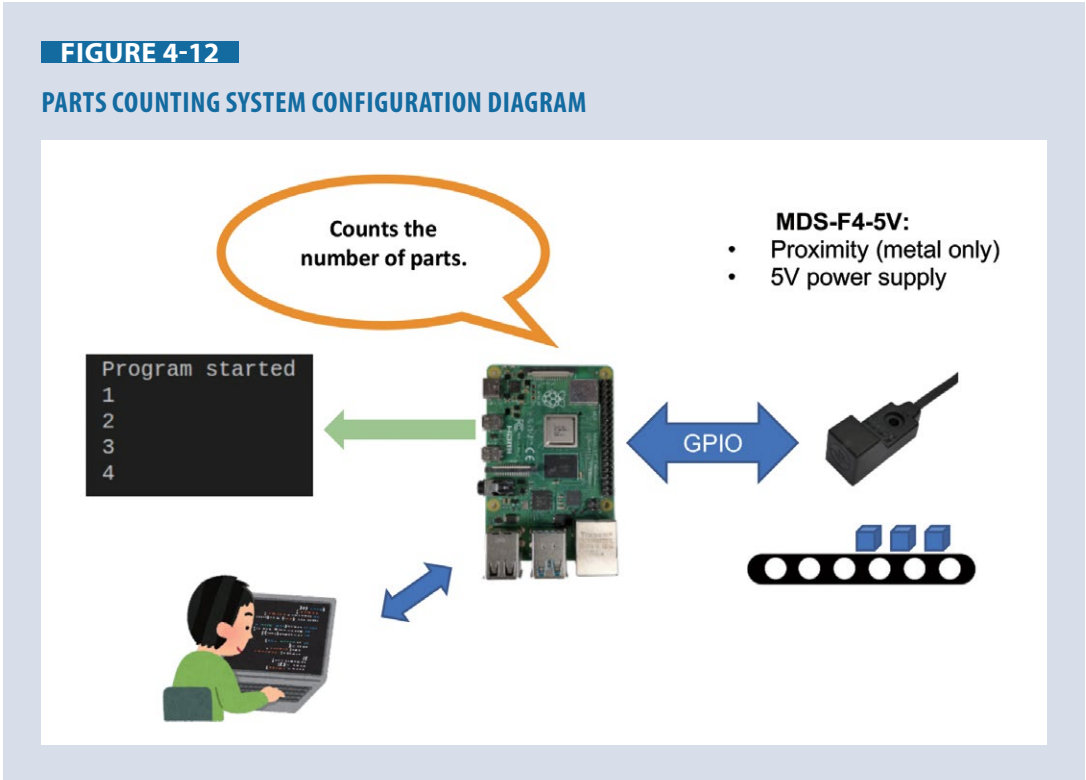

#### 4.2.4 Proximity Sensor MDS-F4-5V [74]

The MDS-F4-5V is used for positioning of processing machines, etc., and position detection of pallets or moving tables. With a detection distance of  $4\text{ mm} \pm 0.5\text{ mm}$ , it detects metallic objects at short distances. This sensor is called the ‘normally open’ type and turns off when no object is detected and turns on when an object is detected. The power supply voltage is 5 V, so it can be driven directly from a microcontroller such as the Raspberry Pi.

Note: Since the proximity sensor detects a short distance, consider using a ToF sensor or other distance sensors if the distance between the part and the sensor is far apart.

The following is an external view of the MDS-F4-5V.

**FIGURE 4-13**  
**EXTERNAL VIEW OF THE MDS-F4-5V**

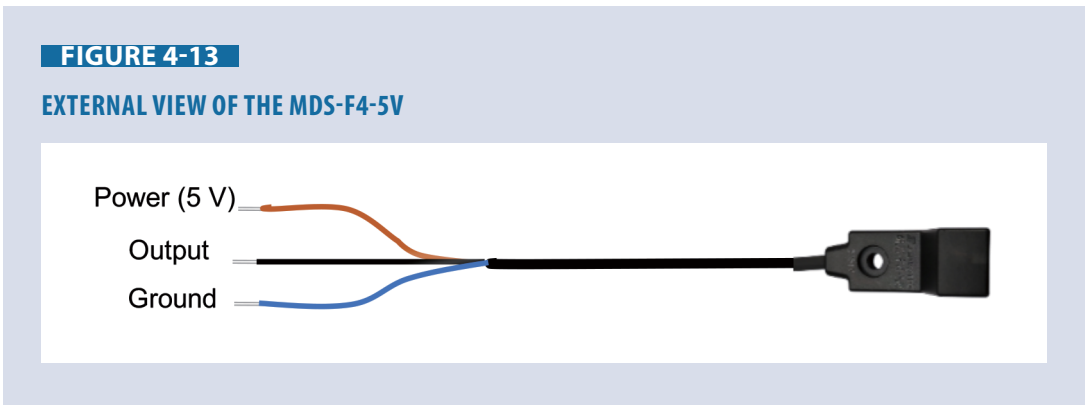

The brown wire connects to the 5 V supply, and the blue wire connects to the ground. Whether or not an object is detected is output on the black wire.



#### 4.2.5 Connecting the MDS-F4-5V to the Raspberry Pi

Figure 14 shows how to connect the MDS-F4-5V to the Raspberry Pi. The power (brown) on the sensor side is connected to the 5 V power supply, and the ground (blue) is connected to the GND. Output (black) is connected to the 3.3 V power supply via a 10 k $\Omega$  pull-up resistor<sup>3</sup> and then to the GPIO25 pin via a 10 k $\Omega$  resistor that protects the input pin.

**FIGURE 4-14**

**CONNECTION DIAGRAM OF RASPBERRY PI AND PROXIMITY SENSOR**

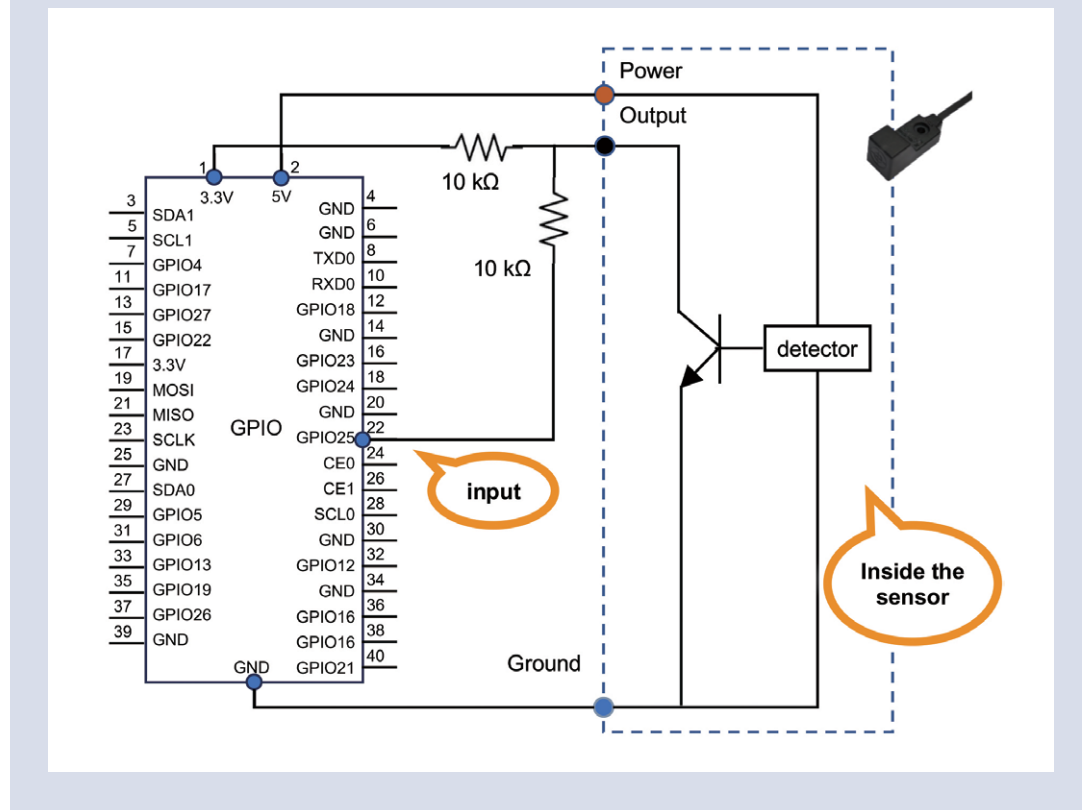

When no metal object is in front of the sensor, the sensor turns off, and the Output becomes High (3.3 V). When a metal object approaches the sensor, the sensor turns on, and the Output becomes Low (0.0 V). In other words, a change in GPIO25 from High to Low indicates that a new object has been detected.



<sup>3</sup> A resistor to ensure that a wire is pulled to a high logical level in the absence of an input signal.

#### 4.2.6 Python Programming of the Parts Counting System

##### STEP 1: Install necessary libraries

First, install a library for using GPIO.

Enter and execute the following command from the terminal.

```
sudo pip install RPi.GPIO
```

##### STEP 2: Coding

Below is a program that processes the signal from the proximity sensor and counts parts.

**FIGURE 4-15**

##### PROXIMITY.PY

```
1  from time import sleep
2  import RPi.GPIO as GPIO
3
4  # define GPIO pin number
5  PIN_NUM = 25
6
7  # initialize count for interrupt
8  count = 0
9
10 # callback function for interrupt
11 def callback(channel):
12     global count
13     count += 1
14     print(count)
15
16 # program starts here
17 print ('Program started')
18
19 GPIO.setmode(GPIO.BCM) # use BCM pin numbering
20 GPIO.setup(PIN_NUM, GPIO.IN) # set BCM 25 as input
21 # detect falling edge and callback function
22 GPIO.add_event_detect(PIN_NUM, GPIO.FALLING,
23                       |   |   |   callback=callback, bouncetime=300)
24
25 # wait for events for 20 seconds
26 sleep(20)
27 print("end")
```

- **Line 1**  
Import the sleep function from the time module. The sleep function makes the program wait for a certain period of time.
- **Line 2**  
Import the RPi.GPIO library and make it accessible under the name “GPIO”.
- **Line 5**  
Set the pin number of the GPIO to be used to the variable “PIN\_NUM”. In this way, replacing numerical values with variables with names that are easy to understand makes the program easier to read and maintain.
- **Line 8**  
Define “count” as a variable to count the number of parts and initialize it to 0.
- **Lines 11-14**  
Define a new function named “callback” to be executed when the GPIO value changes.  
  
The variable “count” is qualified with “global” to indicate that it is the same as the variable defined in line 8. Without “global,” the variable “count” here is valid only in the function “callback” and is considered a different variable from “count” in line 8.  
  
Line 13 increments the counter “count” by one and outputs the new value to the console. “count += 1” is equivalent to “count = count + 1”.
- **Line 17**  
Output a message to the console informing the user that the program has started.
- **Line 19**  
Specify the pin designation method as “BCM numbering”<sup>4</sup>.
- **Line 20**  
Set GPIO 25 as input.
- **Line 22**  
The GPIO.add\_event\_detect function specifies which function to execute when an event occurs. In this example, it means call the function named “callback” when the level of GPIO25 transitions from High to Low.  
  
Also, “bounce=300” specifies that no new events will be generated within 300 msec. This parameter is intended to prevent chattering.

---

<sup>4</sup> “BCM numbering” is a numbering scheme for GPIO defined by Broadcom. The other scheme is the physical numbering based on the pin’s position.

- **Line 26–27**

The function “sleep” keeps the program waiting for 20 seconds. During this time, the program is paused so it does not consume CPU time. If GPIO25 changes from High to Low during the wait, the “callback” function on line 11 is executed. After 20 seconds, the wait is over, a message is issued, and the program terminates.

### STEP 3: Run the program

Now, let’s run the program.

From the VSCode menu, select “Run” → “Run Without Debugging” to start the program.

Put a metallic object (scissors, pliers, etc.) close to the sensor.

If the terminal displays the following, it is working correctly.

```
Program started
1
2
3
4
```

## Chapter 4.3 Acquisition of Environmental Sensor Data

**In this Chapter, we will learn about the following.**

- 4.3.1 Importance of Environmental Data Acquisition in Kaizen**
- 4.3.2 Available Environmental Sensors**
- 4.3.3 Configuration of Environmental Parameter Acquisition System**
- 4.3.4 Understanding the Environmental Sensor BME280**
- 4.3.5 Connecting the BME280 to the Raspberry Pi**
- 4.3.6 Overview of I2C Interface**
- 4.3.7 Preparing for Cloud Service and Programming**
- 4.3.8 Python Program to Process Environmental Parameters**
- 4.3.9 Start the Program Periodically**
- 4.3.10 Observation of Environmental Parameters by the Cloud Service**

### 4.3.1 Importance of Environmental Data Acquisition in Kaizen

Capturing and analyzing environmental parameters is essential for effectively implementing kaizen in a factory. Environmental parameters are the physical conditions under which a process or system operates. They include factors such as temperature, humidity, lighting, air pressure, noise level, and cleanliness.

By monitoring and analyzing environmental parameters, managers can identify potential sources of inefficiency, waste, or quality problems. For example, suppose a process requires a certain temperature range to operate efficiently. In that case, monitoring temperature levels can detect when the process operates outside the proper range, causing reduced productivity or increased waste. Similarly, if a process requires a certain level of air quality, monitoring air quality levels

can identify when filters need to be replaced or other maintenance is required to ensure optimal process operation.

On the other hand, acquiring and analyzing environmental parameters is also important to ensure a safe and healthy work environment for employees. For example, monitoring noise levels can identify when hearing protection is needed. Monitoring cleanliness can also identify potential health hazards, such as airborne contaminants.

From 2019 to 2023, the world realized the threat of infectious diseases. The outbreak at a large U.S. meat processing plant that led to a shortage of processed meat throughout the U.S. again suggests how important it is to monitor environmental parameters at the plant.

Therefore, learning how to obtain environmental parameters is an extremely important process in factory improvement.

#### 4.3.2 Available Environmental Sensors

**FIGURE 4-16**

##### AVAILABLE ENVIRONMENTAL SENSORS

Use	Sensor
Monitoring Operation Status	Accelerometer Vibration Sensor Electric Current Sensor
Monitoring Work Environment	Temperature Sensor Humidity Sensor CO <sub>2</sub> Sensor Pressure Sensor Illumination sensor Noise Sensor Dust Sensor Magnetic Sensor
Measuring Materials or Parts	Weight Sensor Flow Sensor
Detecting Humans or ThingSpeak	Infrared Sensor Laser Sensor Proximity Sensor

As shown in Figure 16, many environmental sensors are used in production. CO<sub>2</sub> sensors, in particular, are increasingly used in many workplaces to reduce the risk of infectious diseases, as they can detect insufficient ventilation in a room.

#### 4.3.3 Configuration of Environmental Parameter Acquisition System

In this example, the sensor unit BME280 measures a room's temperature, humidity, and barometric pressure. The unit is connected to the Raspberry Pi via an interface called I2C. A Python program on the Raspberry Pi retrieves environmental parameters every 10 minutes and sends the data to a cloud service called ThingSpeak to visualize the data.

**FIGURE 4-17**  
**CONFIGURATION DIAGRAM OF THE ENVIRONMENTAL PARAMETER ACQUISITION SYSTEM**

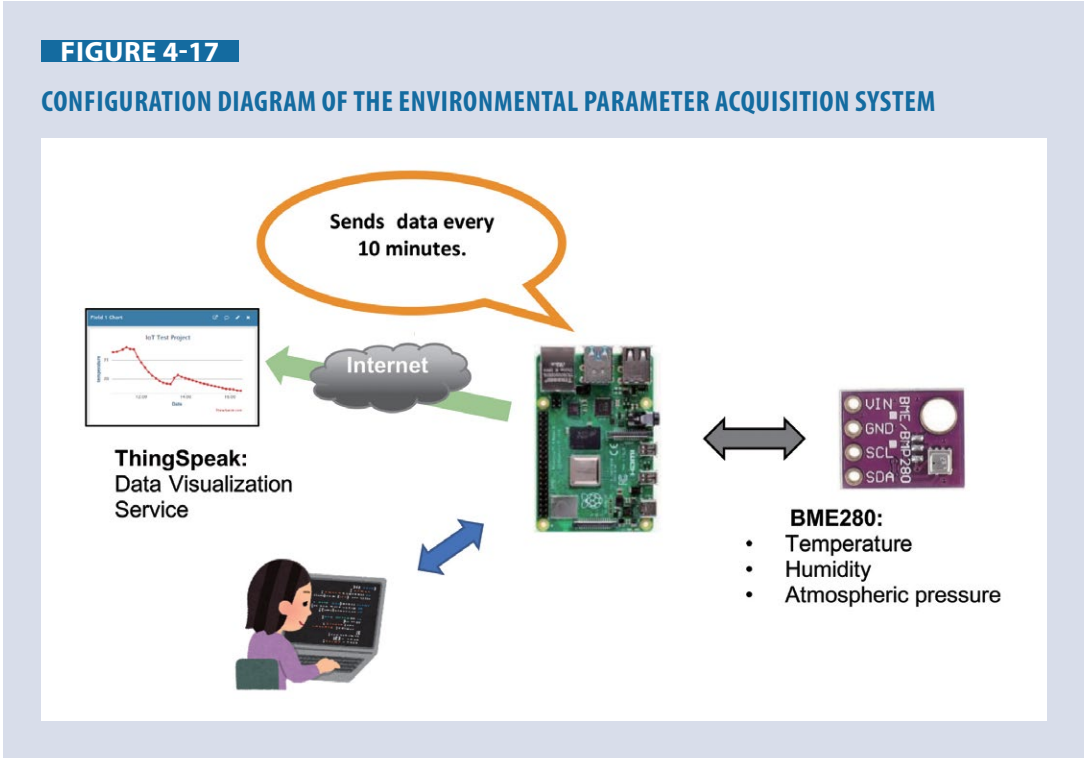

#### 4.3.4 Understanding the Environmental Sensor BME280

The BME280 [75] is a highly accurate sensor that measures temperature, pressure, and humidity. It is used in various applications, including weather monitoring, indoor air quality, and industrial automation.

The BME280 sensor is manufactured by Bosch and has an I2C or SPI interface for easy integration into a microcontroller. It features compact size, low power consumption, and high accuracy. It is often used in applications that require reliable environmental sensing.

As shown in Figure 18, the BME280 is an electronic component in a compact metal-lid LGA (land grid array) package measuring 2.5 x 2.5 mm<sup>2</sup> and 0.93 mm high, which must be surface mounted on a board. As such, it is difficult to build a system manually with this component, so a sensor module is available, in which the BME280 is mounted on a small circuit board. This sensor module is used in this case study.

VIN is a pin for applying power supply voltage. The operating voltage ranges from 1.8 V to 3.3 V. In this example, the 3.3 V power supply of the Raspberry Pi is used. GND is the ground<sup>5</sup> terminal; it is connected to the ground of the Raspberry Pi.

SCL is a pin for transmitting a clock signal. Data is sent in time with this clock. Data is sent out via the SDA pin.

<sup>5</sup> The part of a circuit that determines the voltage reference in the circuit.

**FIGURE 4-18**  
**BME280 SENSOR MODULE**

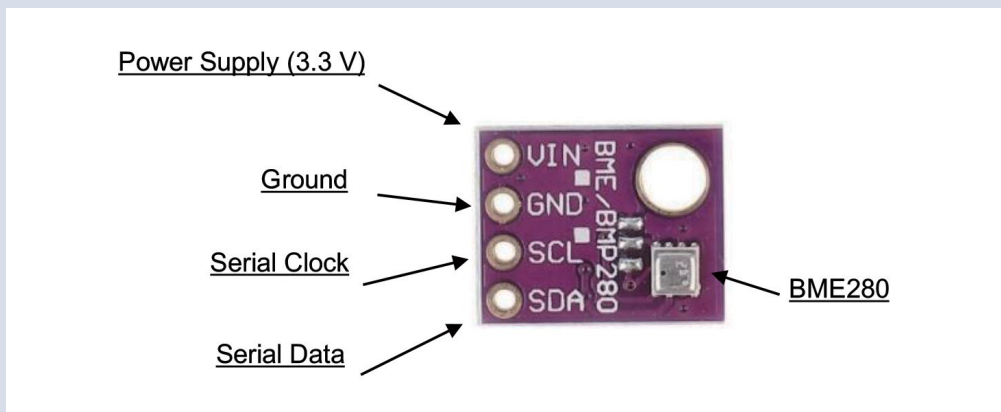

#### 4.3.5 Connecting the BME280 to the Raspberry Pi

Figure 19 shows how to connect the BME280 module to the Raspberry Pi. The I2C interface is assigned to SDA1 (GPIO2) and SCL1 (GPIO3) on the Raspberry Pi. Except for power and ground, only two wires are needed.

**FIGURE 4-19**  
**CONNECTING THE BME280 TO THE RASPBERRY PI**

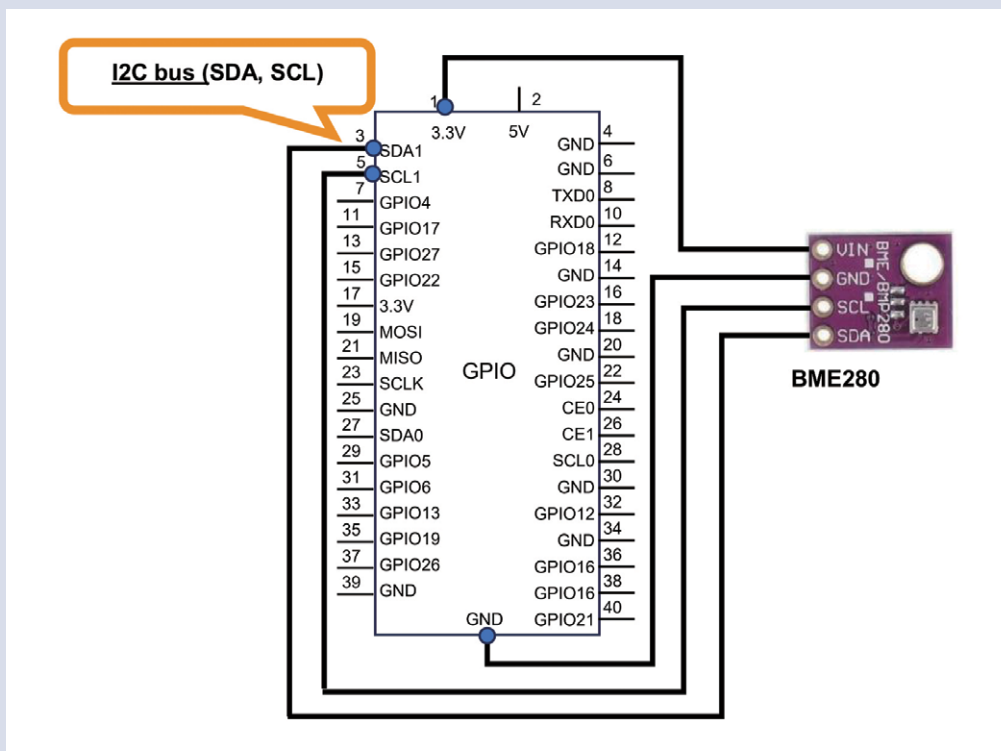

## 4.3.6 Overview of I2C Interface

FIGURE 4-20

## I2C INTERFACE [76]

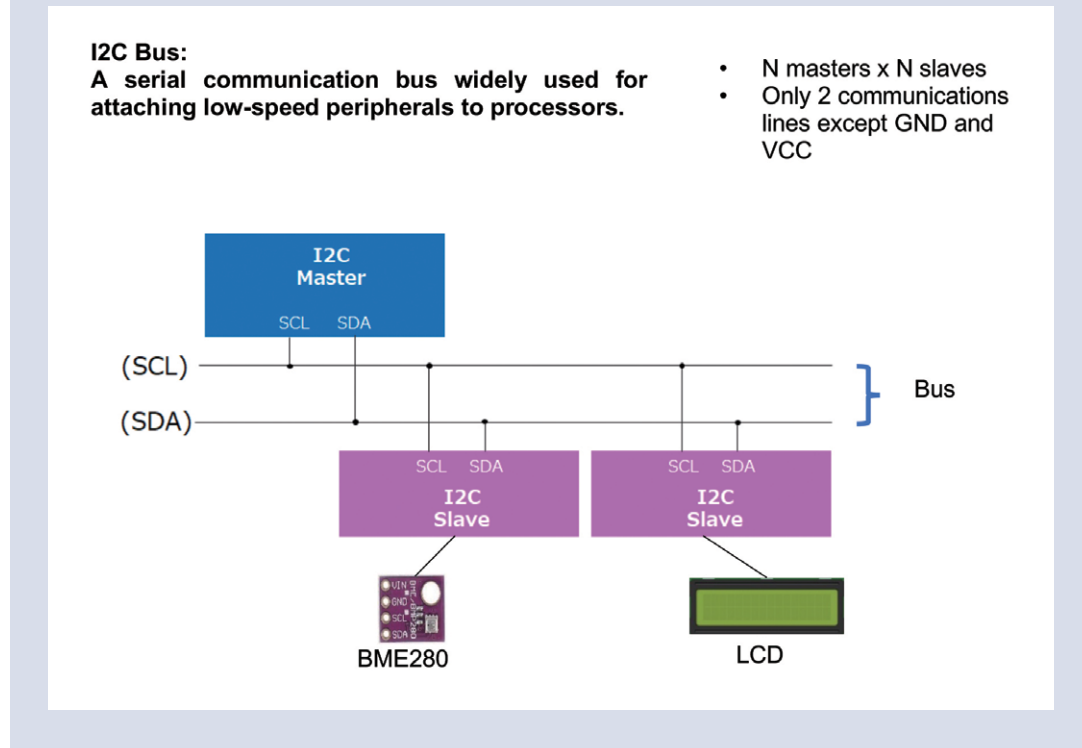

Here is a brief description of the I2C interface.

The I2C interface is a serial communication bus widely used to attach low-speed peripherals to a processor. When multiple devices are connected in parallel, it is necessary to divide the roles: one is to manage and control (master), and the rest are to be controlled (slaves). The I2C interface enables communication between multiple masters and multiple slaves with a minimum of wiring.

Multiple slaves can be added to a bus with only two wires, as shown in Figure 20.

In fact, in this example, two slaves, a BME280 and an LCD, are connected to the Raspberry Pi via an I2C interface. The CPU of the Raspberry Pi plays the role of master.

## 4.3.7 Preparing for Cloud Service and Programming

Before we begin programming, we need to do some preparation.

**STEP 1: Signing up for ThingSpeak**

In this example, data is uploaded to a web service called ThingSpeak, which requires registration. The site is very easy to use and allows immediate data visualization without manipulating CSV or Excel files.

Go to the site <https://thingspeak.com/> and sign up for a free account.





**Source:** The image taken by the author using the service of MathWorks, Inc. [77]

## STEP 2: Creating a channel

You need to create a channel to store data in ThingSpeak.

Log in to ThingSpeak and click on the “New Channel” button.

Fill in the text boxes, Name, Description, etc.

This example defines three fields: temperature, humidity, and pressure.

You can leave the other boxes blank.

**FIGURE 4-21**

### CREATING A CHANNEL

## New Channel

**Name**

**Description**

Field 1

Field 2

Field 3

Field 4

**Source:** The image taken by the author using the service of MathWorks, Inc. [78]

**STEP 3: Install I2C library**

To install the I2C library, enter the following command line from the console.

```
sudo pip3 install smbus
```

Note: “pip3” is a Python package management tool.

Note: SMBus is a Python library for using I2C. It is already installed on newer versions of the Raspberry Pi.

**STEP 4: Install BME280 library**

To install the BME280 library, enter the following command line from the console.

```
sudo pip3 install RPI.BME280
```

We are now ready to start programming.

**STEP 5: Check I2C connection**

Then, it is necessary to check that the wiring is correct and that the BME280 is working properly.

The current status of the I2C can be obtained by entering the following command from the console.

```
i2cdetect -y 1
```

The screen in Figure 22 shows the active I2C connections.

The hexadecimal number H76 indicates the address of BME280.

As mentioned earlier, the I2C interface is also used for the LCD. Its address is shown as H27 on this screen.

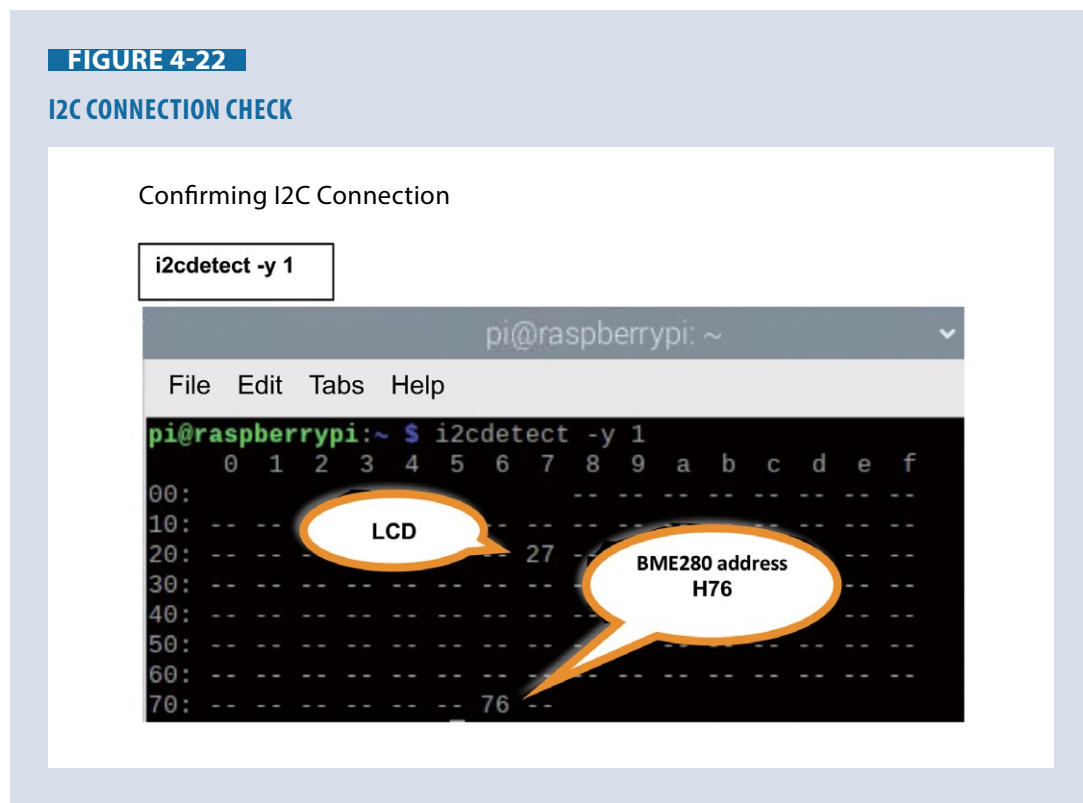
**FIGURE 4-22****I2C CONNECTION CHECK**

**STEP 6: Obtain a key for webhooks****FIGURE 4-23****OBTAINING A KEY FOR WEBHOOK**

The screenshot shows the 'API Keys' management interface. At the top, there are navigation tabs: 'Private View', 'Public View', 'Channel Settings', 'Sharing', 'API Keys', and 'Data Import / Export'. The main content is divided into two sections. The 'Write API Key' section has a text input field containing the key 'NIOJDVMS2GZ2', which is highlighted with a green oval. Below this field is a yellow button labeled 'Generate New Write API Key'. The 'Read API Keys' section has a text input field containing the key '4MC3BMLVYNN'. Below this field is a larger text area for a 'Note'. There are two buttons: a green 'Save Note' button and a red 'Delete API Key' button. At the bottom of the 'Read API Keys' section is a yellow button labeled 'Add New Read API Key'.

**Source:** The image taken by the author using the service of MathWorks, Inc. [79]

When using web services, you must prove the authenticity of yourself and your device.

The process of proving the authenticity of a device is called provisioning. Provisioning requires sending the secret text given to your device to the web service.

In this example, the secret key is obtained from the ThingSpeak website.

From this page on ThingSpeak, you can obtain a “read key” and a “write key.” (Figure 23)

You will need to use these keys when sending and receiving data from the web service.

#### 4.3.8 Python Program to Process Environmental Parameters

Thanks to the BME280 library, obtaining environmental data from a Python program is very easy.

##### **STEP 1: Import necessary libraries.**

We need to import the “smbus2” library to use the I2C interface, the “bme280” library to use BME280, and the “requests” library to use the HTTP connection.

```
import smbus2
import bme280
import requests
```

**STEP 2: Obtain a smbus2 object.**

In an object-oriented language such as Python, to use the functionality of a class, you must first obtain an object of that class.

```
bus = smbus2.SMBus(1)
```

**STEP 3: Obtain sensor data.**

You can get sensor data by simply calling the “sample()” method of the bme280 object and specifying the smbus2 and the I2C address you use.

```
data = bme280.sample(bus, address=0x76)
```

**STEP 4: Extract parameters**

Temperature, humidity, and pressure parameters have already been packed into the data object as properties. You can assign convenient variables from those properties.

```
temp = data.temperature
humid = data.humidity
pressure = data.pressure
```

**STEP 5: Obtain the URL of ThingSpeak and your key.**

You can get the URL of the API and your key from the ThingSpeak website. Store them in convenient variables.

```
address = "https://api.thingspeak.com/update"
key = "NIOJDVMS2GZ2****"
```

**STEP 6: Compose a URL string for the API.**

Using those variables, compose a URL string for the API.

The URL string will become like “https://api.thingspeak.com/update?api\_key=NIOJDVMS2GZ2\*\*\*\*&field1=20.25&field2=40.12&field3=1003.11.”

```
url = "{0}?api_key{1}&field1={2}&field2={3}&field3={4}"
url = url.format(address, key, temp, humid, pressure)
```

**STEP 7: Send the data to ThingSpeak.**

The method “requests.get()” sends an HTTP GET command containing parameters to be sent to ThingSpeak.

```
requests.get(url)
```

The overall program is as follows.

**FIGURE 4-24****EXECUTE.PY**

```

1  # Purpose: Read data from BME280 sensor and send to ThingSpeak
2  # import necessary libraries
3  import smbus2
4  import bme280
5  import requests
6  # instantiate smbus2
7  bus = smbus2.SMBus(1)
8
9  # obtain sensor data at address 0x76
10 data = bme280.sample(bus, address=0x76)
11
12 # get temperature, humidity, and pressure
13 temp = data.temperature
14 humid = data.humidity
15 pressure = data.pressure
16
17 address = "https://api.thingspeak.com/update"
18 key = "NIOJDVMS2GZ2"
19
20 # compose a URL to send data to ThingSpeak
21 url = "{0}?api_key={1}&field1={2}&field2={3}&field3={4}"
22 url = url.format(address, key, temp, humid, pressure)
23
24 # send data to ThingSpeak
25 requests.get(url)

```

Note that you will need to devise error-handling mechanisms, such as a try-catch clause, to make the program more usable.

#### 4.3.9 Start the Program Periodically

One thing is missing from this program.

It sends data only once; repeating every 10 minutes is not written in this program.

Of course, the Python program can be modified to send data to the cloud service every 10 minutes. However, we will show you another way in this example: using the Linux utility cron.

You can schedule jobs for commands, shell scripts, and programs with cron.

When you want Linux to do some recurring job, cron is frequently used.

Windows has a similar utility called Task Scheduler.

In this example, we will use cron to run the program we just wrote every 10 minutes.

All that is required is to add a line like the following to the end of the file called crontab. (Figure 25)

```
*/10 * * * * python3 /home/pi/Desktop/execute.py
```

This command line means “run /home/pi/Desktop/execute.py every 10 minutes.”

**FIGURE 4-25**

**CRONTAB FILE**

crontab file

All lines starting with # are comments, so don't worry about them.

```

GNU nano 5.4 /tmp/crontab.FLzXwj/crontab *
# Edit this file to introduce tasks to be run by cron.
#
# Each task to run has to be defined through a single line
# indicating with different fields when the task will be run
# and what command to run for the task
#
# To define the time you can provide concrete values for
# minute (m), hour (h), day of month (dom), month (mon),
# and day of week (dow) or use '*' in these fields (for 'any').
#
# Notice that tasks will be started based on the cron's system
# daemon's notion of time and timezones.
#
# Output of the crontab jobs (including errors) is sent through
# email to the user the crontab file belongs to (unless redirected).
#
# For example, you can run a backup of all your user accounts
# at 5 a.m every week with:
# 0 5 * * 1 tar -zcf /var/backups/home.tgz /home/
#
# For more information see the manual pages of crontab(5) and cron(8)
#
# m h dom mon dow   command
*/10 * * * * python3 /home/pi/Desktop/execute.py
                    
```

```
*/10 * * * * python3 /home/pi/Desktop/execute.py
```

**4.3.10 Observation of Environmental Parameters by the Cloud Service**

Now, let's run the program for a while, open the cloud service, and watch the environmental data graphed. (Figure 26)

**FIGURE 4-26**

**VISUALIZATION OF ENVIRONMENTAL PARAMETERS**

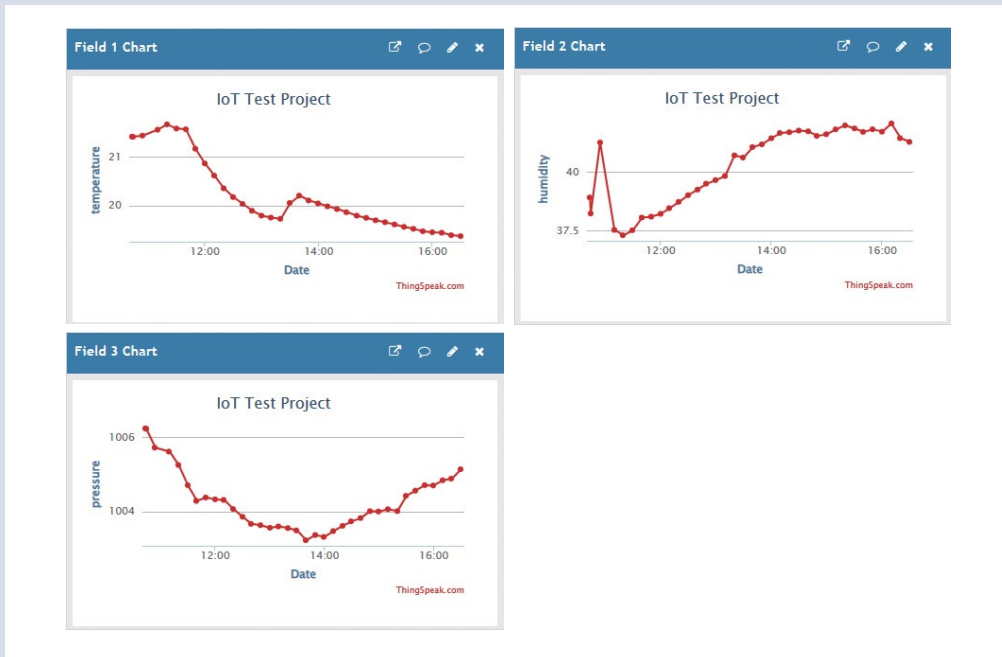

Source: The image taken by the author using the service of MathWorks, Inc. [80]

## Chapter 4.4 Saving Environmental Sensor Data to a File

In this chapter, we will learn how to store data on Raspberry Pi using a CSV file.

**In this chapter, we will learn how to store data on Raspberry Pi using a CSV file.**

This chapter [81] shows how to store various environmental data collected from sensors on the Raspberry Pi. Although external access to the data is limited because it is stored on the Raspberry Pi, you will be able to reference and process the data by using media such as a USB (universal serial bus) memory device.

### 4.4.1 Export to CSV file on Raspberry Pi

What is a CSV file?

CSV stands for Comma Separated Value.

It is a simple file format used to store tabular data, such as a spreadsheet or database. Each line in a CSV file represents a row of data, and each column is, as the name suggests, separated by a comma. CSV files are widely used for data exchange between different software applications, as they are lightweight and easy to read and write.

Usually, CSV files have the file extension .csv.

CSV File example:

```
temperature(C), Pressure(hPa), Date_Time
32.63316506, 998.2909649, 2023/7/10 14:01:29
32.65137306, 998.3355289, 2023/7/10 14:01:39
```

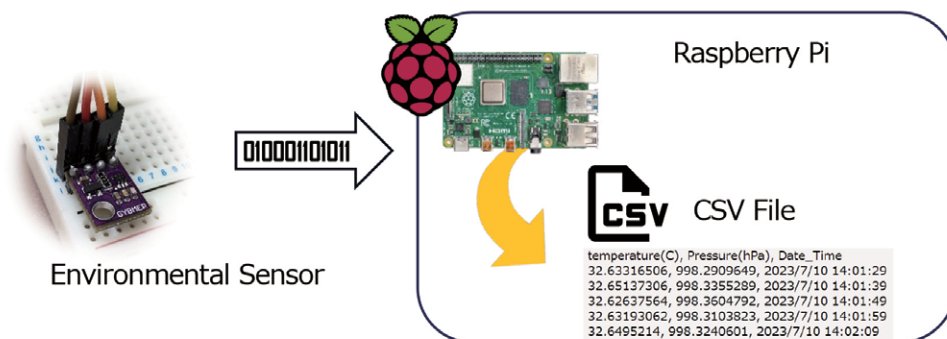

The following procedure uses Python on a Raspberry Pi to write out the data acquired by the BMP280 sensor device, along with timestamps, to 'BMP280\_Sensor\_data.csv' on the same Raspberry Pi as an example.

#### STEP 1: Installation of required libraries

What are libraries?

Python libraries are collections of modules that allow you to perform many tasks without writing any code. They are pre-written code that you can use to solve common problems and speed up your development process. Python has a vast collection of libraries that can be used for various purposes, such as data analysis, web development, machine learning, and more.



The standard Python libraries such as `os.path`, `csv`, and `time` can be used without performing a separate installation.

The additional library for the sensor is not installed by default.

To install the BMP280 and SMBus libraries, enter the following command line from the console.

`pip install bmp280`

```
● rasp@raspberrypi:~/Desktop $ pip install bmp280
Looking in indexes: https://pypi.org/simple, https://www.piwheels.org/simple
Collecting bmp280
  Downloading https://www.piwheels.org/simple/bmp280/bmp280-0.0.4-py3-none-any.whl (5.7 kB)
Requirement already satisfied: i2cdevice>=0.0.6 in /usr/local/lib/python3.9/dist-packages (from bmp280) (0.0.7)
Installing collected packages: bmp280
Successfully installed bmp280-0.0.4
```

Successfully installed bmp280-0.0.4

`pip install SMBus2`

```
● rasp@raspberrypi:~/Desktop $ pip install SMBus2
Looking in indexes: https://pypi.org/simple, https://www.piwheels.org/simple
Collecting SMBus2
  Using cached https://www.piwheels.org/simple/smbus2/smbus2-0.4.2-py2.py3-none-any.whl (13 kB)
Installing collected packages: SMBus2
Successfully installed SMBus2-0.4.2
```

Successfully installed SMBus 2-0.4.2



**STEP 2: Creating Python code on Raspberry Pi**

This step shows how to create a Python program to export environmental data acquired from the environmental sensor BMP280 with a time stamp to a specified CSV file on the Raspberry Pi.

Sample Program Code:

```

1  #!/usr/bin/env python3
2  import os.path
3  import csv
4  import time
5  import datetime
6  from bmp280 import BMP280
7  from smbus2 import SMBus
8
9  bus = SMBus(1)
10 bmp280 = BMP280(i2c_dev=bus)
11
12 filename = 'BMP280_Sensor_data' + '.csv' # CSV file name
13 file_exists = os.path.isfile(filename) # File check
14
15 # Open CSV file with appned mode
16 with open(filename, 'a', newline='') as csvfile:
17     writer = csv.writer(csvfile)
18
19     # In case no file exist, add header line
20     if not file_exists:
21         writer.writerow(['temperature(C)', 'Pressure(hPa)', 'Date_Time'])
22
23     # retrieve data and append on CSV file
24     while True:
25         temperature = bmp280.get_temperature()
26         pressure = bmp280.get_pressure()
27
28         current_datetime = datetime.datetime.now()
29         formatted_date = current_datetime.strftime("%Y/%m/%d")
30         formatted_time = current_datetime.strftime("%H:%M:%S")
31
32         data1= str(temperature)
33         data2= str(pressure)
34         data3=formatted_date + ' ' + formatted_time
35
36         writer.writerow([data1, data2, data3])
37         csvfile.flush() # flush the data
38
39         print('Write the data on the CSV File ' + filename)
40         print('To stop this program, press "ctrl + C" on the terminal window')
41         print(temperature)
42         time.sleep(10) # sleep for the time specified

```

Code Description:

Import a set of libraries required for processing.

```
1. #!/user/bin/env python3
2. import os.path
3. import csv
4. import time
5. import datetime
6. from bmp280 import BMP280
7. from smbus2 import SMBus
8.
```

Specify the value as “1” for the SMBus argument to initialize for I2C communication.

```
9. bus = SMBus(1)
10. bmp280 = BMP280(i2c_dev=bus)
11.
```

Specify the name of the CSV file to which the data will be exported and open the file in append mode.

```
12. filename = 'BMP280_Sensor_data' + '.csv' # CSV file name
13. file_exists = os.path.isfile(filename) # File check
14.
15. # Ope CSV file with append mode
16. with open(filename, 'a', newline='') as csvfile:
17.     writer = csv.writer(csvfile)
18.
```

If the file does not exist, add a header line to the first line and create the file.

```
19. # In case no file exists, add header line
20. if not file_exists:
21.     writer.writerow(['temperature(C)', 'Pressure(hPa)', 'Date_Time'])
22.
```

Read data from the sensor and store temperature and atmospheric pressure data in their respective variables.

```
23. # retrieve data and append on CSV file
24. while True:
25.     temperature = bmp280.get_temperature()
26.     pressure = bmp280.get_pressure()
27.
```

Obtains and formats the current time.

```
28.     current_datetime = datetime.datetime.now()
29.     formatted_date = current_datetime.strftime("%Y/%m/%d")
30.     formatted_time = current_datetime.strftime("%H:%M:%S")
31.
```

Store each data for export.

```

32. data1= str(temperature)
33. data2= str(pressure)
34. data3=formatted_date + ' ' + formatted_time
35.

```

Export to CSV file.

```

36. writer.writerow([data1, data2, data3])
37. csvfile.flush() # flush the data
38.

```

Displays messages indicating that the data has been exported to a CSV file.

```

39. print('Write the data on the CSV File ' + filename)
40. print('To stop this program, press "ctrl + C" on the terminal window')
41. print(temperature)

```

Wait for 10 seconds and repeat reading data.

```

42. time.sleep(10) # sleep for the time specified.

```

### STEP 3: Confirmation of results

Run the code and see the execution results:

Execute the created program and check if the data from the environmental sensor is correctly exported to a CSV file.

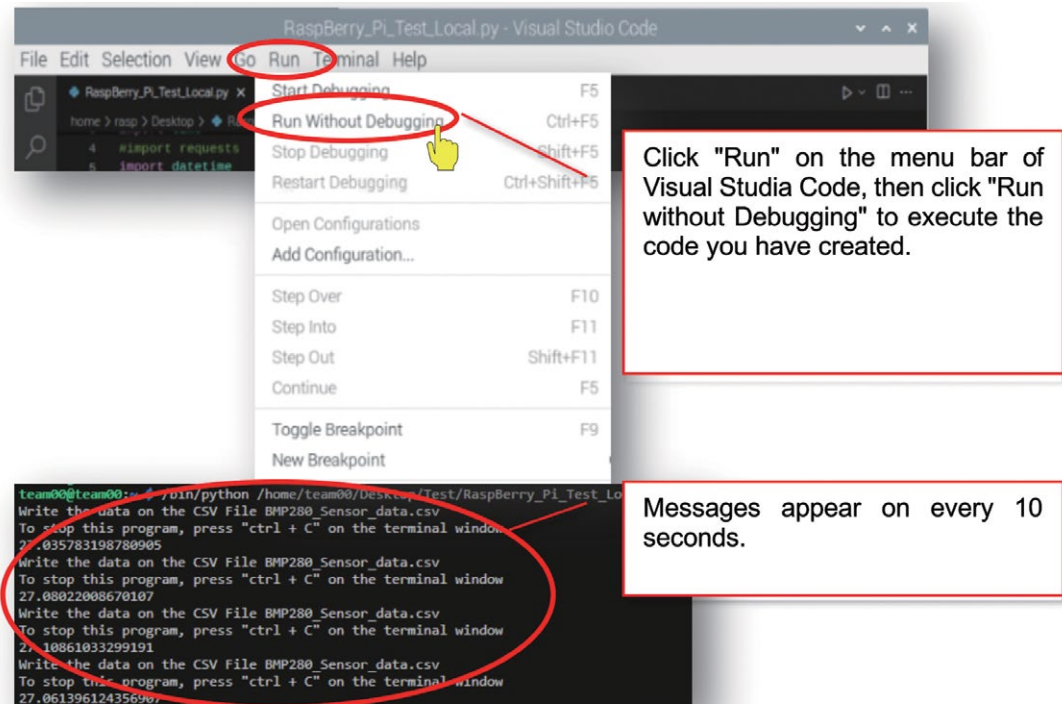

Output file:  
Check the contents of BMP280\_Sensor\_data.csv.  
Enter the following command line from the terminal.

```
tail /tail/home/team00/Desktop/Test/BMP280_Sensor_data.csv
```

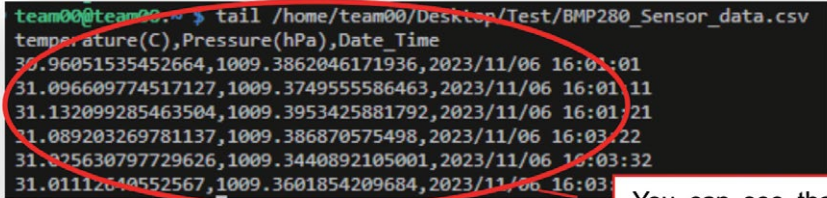

You can see that data has been appended in the CSV file.

In tabular form, you can see the following data stored.

temperature(C)	Pressure(hPa)	Date_Time
30.96051535	1009.386205	2023/11/6
31.09660977	1009.374956	2023/11/6
31.13209929	1009.395343	2023/11/6
31.08920327	1009.386871	2023/11/6
31.0256308	1009.344089	2023/11/6
31.01112641	1009.360185	2023/11/6

**Summary of this chapter**

- ✓ Understood how to export to a CSV file.

### Chapter 4.5 Real-Time Synchronization of Data

**In this chapter, we will learn how to transfer collected sensor data externally by exporting to InfluxDB Cloud.**

To perform Digital Kaizen, it is important to acquire numerical values from sensors and other sources on a regular basis and analyze these values to read the occurrence of abnormalities and defects. For this purpose, it is necessary to transfer the acquired numerical values as data to an external file to be shared within the company.

In this chapter, you will learn how to transfer the data collected by Raspberry Pi to a cloud environment that can be referenced externally.

The following is a candidate as a tool to be used here.

- InfluxDB Cloud

InfluxDB Cloud is a service provided by InfluxData that offers InfluxDB, a database system specialized for processing time-series data, in the cloud.

It is suitable for processing real-time data sent by sensors such as IoT, and since it is provided in the cloud, you can start using it immediately.

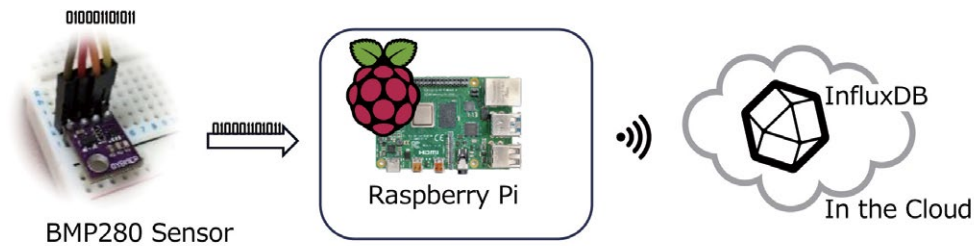

#### 4.5.1 Export to InfluxDB Cloud

What is InfluxDB Cloud?

InfluxDB Cloud is a cloud-based time series database service provided by InfluxData. InfluxDB is an open-source time-series database function that provides a full range of features for handling time-series data generated from IoT devices and other sources.



<p><b>What is InfluxDB?</b></p> <p>Build real-time applications for analytics, IoT, and cloud-native services in less time with less code using InfluxDB.</p> <p><b>Find the right product →</b></p>	<p><b>In the Cloud</b></p> <p><b>InfluxDB Cloud Serverless</b> Fully managed, elastic, multi-tenant service</p> <p><b>InfluxDB Cloud Dedicated</b> Fully managed, single-tenant service</p>	<p><b>On-Prem</b></p> <p><b>InfluxDB Clustered</b> Self-managed database for on-prem or private cloud deployments</p>
--	---	---

**Source:** The image taken by the author using the service of InfluxData Inc. [82]

InfluxDB provides data compression, indexing, and other high-speed data processing, as well as data collection, visualization, alerts, analysis, and other management functions as SaaS in the cloud.

**STEP 1: Preparation on the InfluxDB Cloud**

To use InfluxDB as a destination for sensor data, there is a need to prepare the data on InfluxDB Cloud.

To do so, first log in to the InfluxDB site and perform the necessary configuration.

(<https://www.influxdata.com/>)

Click on "Log In".

Select "Log in to InfluxDb Cloud 2.0".

Select "GOOGLE".

Then, press the "LOG IN" button.

In this example, Login is done using a Google ID.



## Create account and organization:

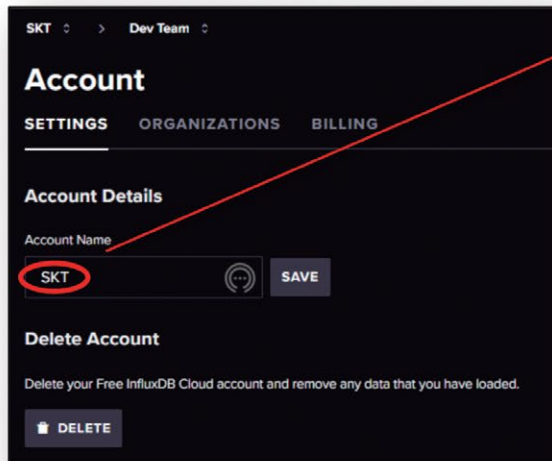

Specify the Account Name from Settings. In this example shown on the screen, it is "SKT" (⑧) specified in the Worksheet 3.6.1.

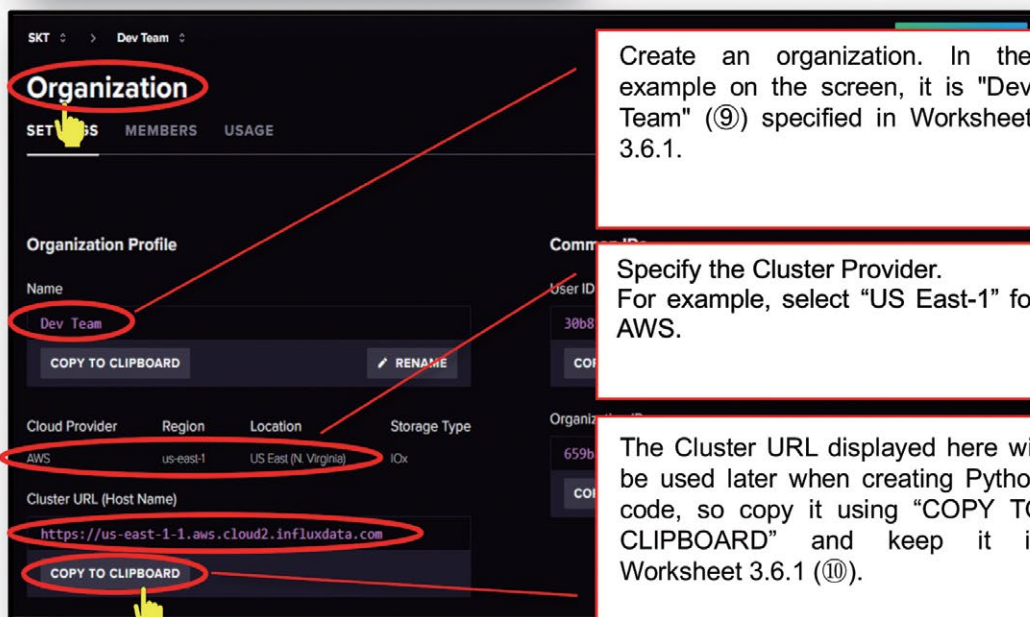

Create an organization. In the example on the screen, it is "Dev Team" (⑨) specified in Worksheet 3.6.1.

Specify the Cluster Provider. For example, select "US East-1" for AWS.

The Cluster URL displayed here will be used later when creating Python code, so copy it using "COPY TO CLIPBOARD" and keep it in Worksheet 3.6.1 (⑩).

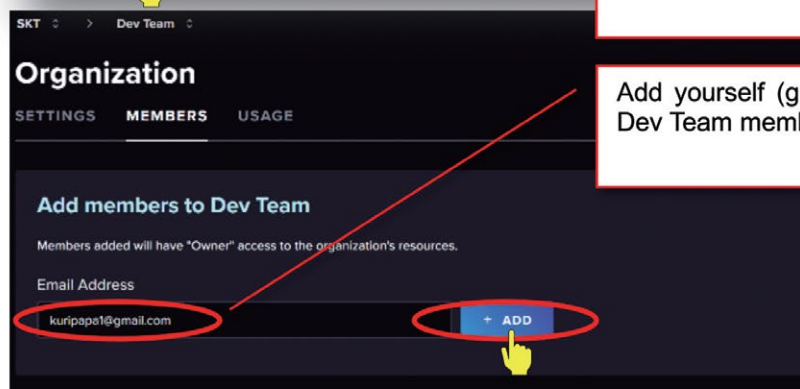

Add yourself (gmail address) to the Dev Team members.

In a later step, we will use the Cluster URL recorded here, please keep it on Worksheet 3.6.1.

### Create Bucket:

A bucket is a container for storing time-series data, which can be used for query execution and visualization in addition to data storage.

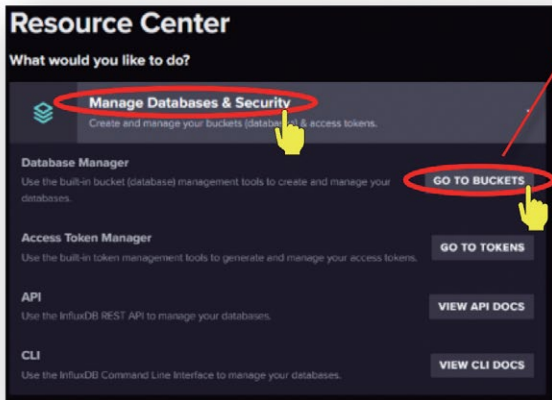

Select "GO TO BUCKETS" from "Manage Database & Security" in the "Resource Center" panel.

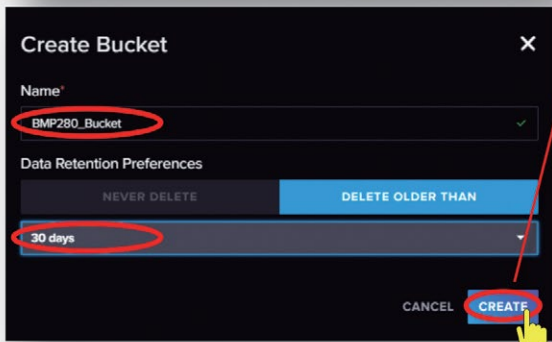

Create a new bucket "BMP280\_Bucket" (Ⓜ in Worksheet 3.6.1) with 30 days retention.

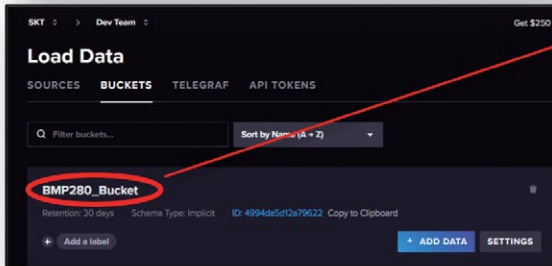

"BMP280\_Bucket" was created.



## Creation of API token:

From "Manage Database & Security", select "GO TO TOKENS".

Select "All Access API Token" from "GENERATE API TOKEN".

Confirm the contents and click "SAVE".

"All Access API Token" is added. This API token will be used later in the creation of Python code section. Copy the created API token and store it using "COPY TO CLIPBOARD" in Worksheet 3.6.1 (12).

The token information recorded here will be used in a later step, so please keep it in Worksheet 3.6.1.

**STEP 2: Installation of required libraries on Raspberry Pi**

The Python library for influxdb is not installed by default.

To install the influxdb and influxdb\_client libraries onto Raspberry Pi, enter the following command line from the terminal window and execute.

```
pip install influxdb
```

```
team00@team00:~$ pip install influxdb
Looking in indexes: https://pypi.org/simple, https://www.piwheels.org/simple
Collecting influxdb
  Using cached https://www.piwheels.org/simple/influxdb/influxdb-5.3.1-py2.py3-none-any.whl (77 kB)
Requirement already satisfied: six>=1.10.0 in /usr/lib/python3/dist-packages (from influxdb) (1.16.0)
Requirement already satisfied: python-dateutil>=2.6.0 in /usr/lib/python3/dist-packages (from influxdb) (2.8.1)
Requirement already satisfied: pytz in /usr/lib/python3.9/site-packages (from influxdb) (2023.3.post1)
Requirement already satisfied: requests>=2.17.0 in /usr/lib/python3/dist-packages (from influxdb) (2.25.1)
Requirement already satisfied: msgpack in /usr/lib/python3.9/site-packages (from influxdb) (1.0.7)
Installing collected packages: influxdb
Successfully installed influxdb-5.3.1
```

Successfully installed influxdb-5.3.1

```
pip install influxdb_client
```

```
team00@team00:~$ pip install influxdb_client
Looking in indexes: https://pypi.org/simple, https://www.piwheels.org/simple
Collecting influxdb_client
  Using cached https://www.piwheels.org/simple/influxdb-client/influxdb_client-1.38.0-py3-none-any.whl (743 kB)
Requirement already satisfied: urllib3>=1.26.0 in /usr/lib/python3/dist-packages (from influxdb_client) (1.26.5)
Requirement already satisfied: reactivex>=4.0.4 in /usr/lib/python3.9/site-packages (from influxdb_client) (4.0.4)
Requirement already satisfied: setuptools>=21.0.0 in /usr/lib/python3/dist-packages (from influxdb_client) (52.0.0)
Requirement already satisfied: certifi>=14.05.14 in /usr/lib/python3/dist-packages (from influxdb_client) (2020.6.20)
Requirement already satisfied: python-dateutil>=2.5.3 in /usr/lib/python3/dist-packages (from influxdb_client) (2.8.1)
Requirement already satisfied: typing-extensions<5.0.0,>=4.1.1 in /usr/lib/python3.9/site-packages (from reactivex>=4.0.4->influxdb_client) (4.8.0)
Installing collected packages: influxdb-client
Successfully installed influxdb-client-1.38.0
```

Successfully installed influxdb-client-1.38.0

**STEP 3: Create Python code on the Raspberry Pi**

Create the Python code “Raspberry\_Pi\_DB\_Test.py” to export data to the “BMP280\_Bucket” of the InfluxDB Cloud you created in the previous step.

Sample Program Code:

```

1  #!/usr/bin/env python3
2  import influxdb
3  import influxdb_client, os, time
4  from influxdb_client import InfluxDBClient, Point, WritePrecision
5  from influxdb_client.client.write_api import SYNCHRONOUS
6  import requests
7  import datetime
8  from bmp280 import BMP280
9  from smbus2 import SMBus
10
11 # InfluxDB Cloud connection information
12 token="PF_x1_NuEEAhZgHCz1iHs4_lbLWB0LTdh1qyMwDEXrCDUa_eDzfwcI8W1qbPy8IdsiN0_jj-vVYJ0bVsRWYoBg=="
13 org = "Dev Team"
14 url = "https://us-east-1-1.aws.cloud2.influxdata.com"
15 bucket="BMP280_Bucket"
16
17 # Connect to InfluxDB Cloud
18 client = InfluxDBClient(url=url, token=token)
19
20 # Create API Client to write data crontab
21 write_api = client.write_api(write_options=SYNCHRONOUS)
22
23 bus = SMBus(1)
24 bmp280 = BMP280(i2c_dev=bus)
25 #BMP280(i2c_addr=0x77, i2c_dev=bus)
26
27 temperature = bmp280.get_temperature()
28 pressure = bmp280.get_pressure()
29
30 current_datetime = datetime.datetime.now()
31 formatted_date = current_datetime.strftime("%Y/%m/%d")
32 formatted_time = current_datetime.strftime("%H:%M:%S")
33
34 data1= temperature
35 data2= pressure
36 data3=formatted_date + ' ' + formatted_time
37
38 # Create datapoint to be sent
39 point = Point("sensor_data") \
40     .tag("location", "room1") \
41     .field("temperature", data1) \
42     .field("pressure", data2) \
43     .field("timestamp", data3)
44 # Write data to API
45 write_api.write(bucket=bucket, org=org, record=point)
46 print(temperature)
47 print(pressure)
48 print(formatted_time)

```

Code Description:

Import the necessary libraries.

```

1. #!/usr/bin/env python3
2. import influxdb
3. import influxdb_client, os, time
4. from influxdb_client import InfluxDBClient, Point, WritePrecision
5. from influxdb_client.client.write_api import SYNCHRONOUS
6. import requests
7. import datetime
8. from bmp280 import BMP280
9. from smbus2 import SMBus
10.

```

Configure the API token information, organization information, Cluster URL of the implemented site, and InfluxDB connection information such as the created bucket that you have stored in Worksheet 3.6.1.

```

11. # InfluxDB Cloud connection information
12. token="Your TOKEN Info12 here"
13. org = "Your Organization Info9 here"
14. url = "Your Cluster URL Info10 here"
15. bucket="Your Bucket Info11 here"
16.

```

Connect to InfluxDB.

```

17. # Connect to InfluxDB Cloud
18. client = InfluxDBClient(url=url, token=token)
19.
20. # Create API Client to write data
21. write_api = client.write_api(write_options=SYNCHRONOUS)
22.

```

Specify “1” for the SMBus argument to initialize for I2C communication.

```

23. bus = SMBus(1)
24. bmp280 = BMP280(i2c_dev=bus)
25. #BMP280(i2c_addr=0x77, i2c_dev=bus)
26.

```

Read data from the sensor and store temperature and atmospheric pressure data in their respective variables.

```

27. temperature = bmp280.get_temperature()
28. pressure = bmp280.get_pressure()
29.

```

Obtain and format the current time.

```
30. current_datetime = datetime.datetime.now()
31. formatted_date = current_datetime.strftime("%Y/%m/%d")
32. formatted_time = current_datetime.strftime("%H:%M:%S")
33.
```

Store each data point for export.

```
34. data1= temperature
35. data2= pressure
36. data3=formatted_date + ' ' + formatted_time
37.
38. # Create datapoint to be sent
39. point = Point("sensor_data") \
40.     .tag("location", "room1") \
41.     .field("temperature", data1) \
42.     .field("pressure", data2) \
43.     .field("timestamp", data3)
```

Write data to the InfluxDB bucket.

```
44. # Write data to API
45. write_api.write(bucket=bucket, org=org, record=point)
46. print(temperature)
47. print(pressure)
48. print(formatted_time)
```

**STEP 4: Confirm execution results**

Run the code and see the execution results:

Execute the created program and check if the data from the environmental sensor is correctly exported to the InfluxDB Cloud.

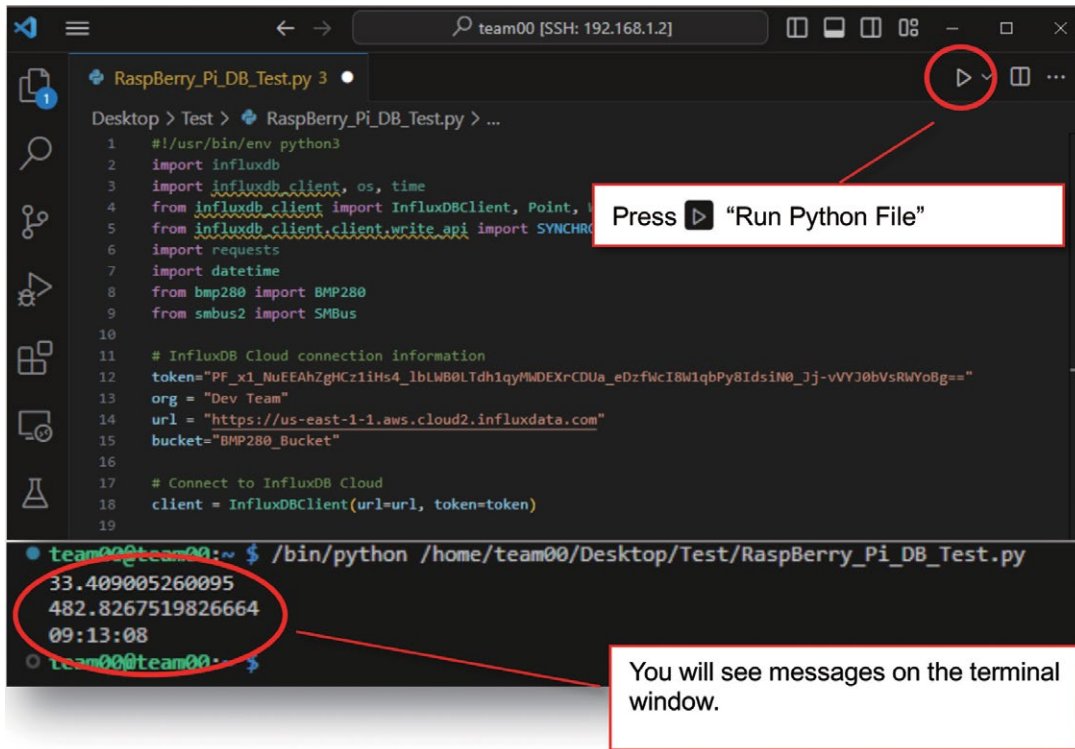

Check the execution result on the InfluxDB Cloud side:

The screenshot shows the InfluxDB Cloud Data Explorer interface. The left sidebar shows the Schema Browser with the following settings: Bucket: BMP280\_Bucket, Measurement: sensor\_data, Fields: pressure, temperature, timestamp (all checked), and Tag Keys: location. The main area shows a SQL query: `SELECT * FROM "sensor_data" WHERE time >= now() - interval '5 minutes' AND ("pressure" IS NOT NULL OR "temp`. The RUN button is highlighted. A text box explains: "Press the Data Explorer [⌘] from InfluxDB Cloud menu pane. Select "BMP280\_Bucket" for Bucket, "sensor\_data" for Measurement, Check ✓ for all Fields, Click "RUN"."

The bottom screenshot shows the result area with the following data table:

table	location	pressure	temperature	time
_result	no group string	no group double	no group double	no group dateTime:RFC3339
0	room1	1006.342704617296	31.61599255217227	2023-07-21T02:21

A text box explains: "The transferred data is displayed in the Result area at the bottom of the screen." The first row of data is circled in red.



**STEP 5: Registration with crontab**

Make cron registration for periodic (every 5 minutes in this case) measurements from BMP280. To edit the cron table, enter the following command from the terminal window and press enter.

```
rasp@Raspberrypi:~ $ crontab -e
```

Add the following line to the crontab configuration file and store it.

```
*/5 * * * * python3 /home/team0X/Desktop/Test/Raspberry_Pi_DB_Test.py
```

**Worksheet 3.6.1**

Exercise Worksheet				
Section	No.	Item	specified value	Example in the case
3.6.1	⑧	InfluxDB Cloud Account Name		SKT
	⑨	InfluxDB Cloud Organization		Dev Team
	⑩	Cloud Provider Cluster URL		<a href="https://us-east-1-1.aws.cloud2.influxdata.com">https://us-east-1-1.aws.cloud2.influxdata.com</a>
	⑪	Bucket Name		BMP280_Bucket
	⑫	API TOKEN		---
	⑬	Measurement		sensor_data
	⑭	tag		"location", "room1"
	⑮	field1		"temperature"
	⑯	field2		"pressure"
	⑰	field3		"timestamp"

**Summary of this chapter**

✓ Understood exporting data to InfluxDB Cloud.

**Chapter 4.6 Data Visualization and Alert Transmission**

In this chapter, we will learn how to visualize collected sensor data using Grafana.

In the previous section, you learned how to export values acquired from sensors to an external InfluxDB Cloud service to convert them into time-based data. To send a notification of an abnormality or problem as soon as possible, it is necessary to visualize the data and to automatically alert the user when an abnormality or problem occurs.

In this chapter, we will learn how to visualize the data collected by Raspberry Pi using graphs and how to notify the administrator using e-mail functions.

Possible candidates for tools to be utilized here are,

Visualization Tools:

- Google Spreadsheet
- Grafana
  - using Grafana Cloud offered as SaaS on the cloud
  - using standalone code deployed on Raspberry Pi
- Microsoft Power BI



Alert Tools:

- Send alert messages to Slack<sup>6</sup>
- Send alerts to any e-mail address

Each tool has its own strengths and weaknesses, but the recommendations throughout are as follows.

Number	Recommended	Data Source	Visualize Tool	Alert Tool	Misc.
①	++	InfluxDB Cloud	Grafana Cloud		Requires integration of multiple cloud services
②	+	Google spread-sheet	Google Apps Script		Code development with Google Apps Script required.
③	—	InfluxDB on local	Grafana on local		Needs to be installed on each Raspberry Pi
④	—	Google spread-sheet	Power BI	N/A	Automatic data update not possible

Thereafter, this chapter will discuss how to visualize data and send alerts using number ① “InfluxDB Cloud” and “Grafana Cloud” which are highly recommended in the above table.

#### 4.6.1 Visualization and Alerting with InfluxDB Cloud and Grafana Cloud

What is Grafana Cloud?

Grafana Cloud is a SaaS observability platform on the cloud managed by Grafana Labs. The platform enables the collection, visualization, and alert notification of observables and logs without the need for a proprietary mechanism.

As a fully managed service built on the cloud, it is scalable and does not require users to manage and maintain their own infrastructure. (<https://grafana.com/pricing/>)

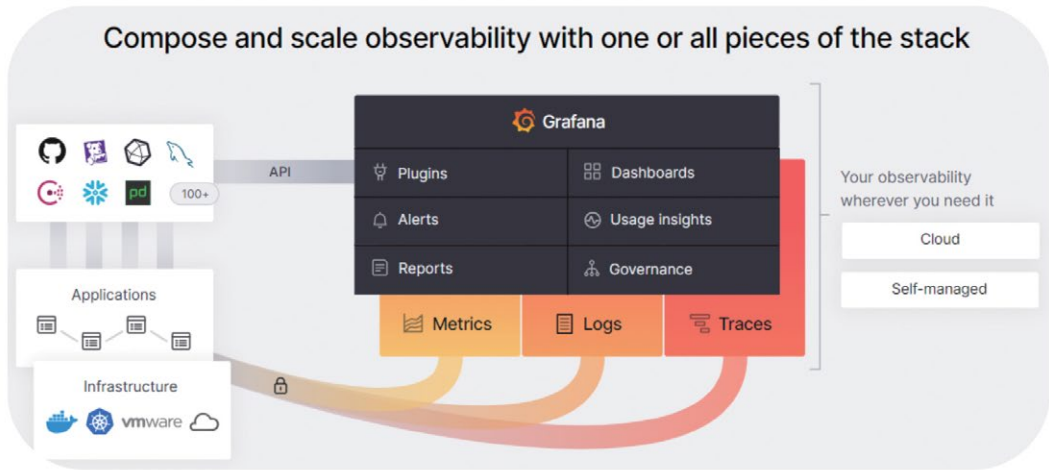

**Grafana Cloud Pricing**  
Options for every user, organization, and use case

Cloud Free	Cloud Pro	Cloud Advanced
<b>FREE</b>	<b>\$29</b> /month plus usage	<b>\$299</b> /month plus usage
An actually useful free tier. Access Cloud features, but with limited usage. No credit card required.	For most companies when you have more users and data.	When you need multiple Enterprise Plugins and other enterprise-level features.
<b>Monthly usage limited to</b>	<b>Included monthly usage</b>	<b>Included monthly usage</b>
50 GB Logs 3 Monthly Active Users 50 GB Traces 10k Metrics 500 k6 Virtual User Hours All Enterprise plugins	100 GB Logs 5 Monthly Active Users 100 GB Traces 20k Metrics 1000 k6 Virtual User Hours Add-on: Enterprise plugin	100 GB Logs 5 Monthly Active Users 100 GB Traces 20k Metrics 1000 k6 Virtual User Hours All Enterprise plugins
<b>Support</b> Community Support Only	<b>Support</b> 8x5 (M-F) Support	<b>Support</b>
<a href="#">Start Free</a>	<a href="#">Start Unlimited Usage Trial</a>	

**Free account has limitations on data capacity, retention period, and other usage fees, but almost all feature functions are available.**

Source: The image taken by the author using the service of Grafana Labs. [83]

## STEP 1: Connect to Grafana Labs

The first screenshot shows the Grafana Labs homepage with the "Create free account" button circled in red. A red arrow points from this button to a text box on the right.

The second screenshot shows the "Sign up for Grafana Cloud" page. The "Google" sign-up option is circled in red, with a red arrow pointing to a text box on the right. Below the sign-up options are fields for "Email" and "Password", a checkbox for "Send me news and feature updates", and a "Create my account" button.

The third screenshot shows the Grafana Cloud Portal dashboard for user "kuripapa1". The "Grafana" card in the "ORG SETTINGS" section has a red circle around it, and a red arrow points from this circle to a text box on the right. The "Launch" button on the Grafana card is also circled in red.

Access "<https://grafana.com/>" from your browser. Click on "Create free account".

Select Sign up using Google ID.

Launch "Grafana".

### STEP 2: Configure the data source (FlightSQL)

InfluxDB Cloud 2.0 requires the use of the “FlightSQL” Plug-in as a Data Source.

The image consists of three screenshots from the Grafana Cloud interface, illustrating the process of installing the FlightSQL data source plugin. Red callout boxes with arrows point to specific UI elements, and yellow hand icons indicate where to click.

- Top Screenshot:** Shows the Grafana Cloud home page. A red callout box says "Select 'Connect data' to start setting up the connection destination." A yellow hand icon points to the "+ Connect data" button.
- Middle Screenshot:** Shows the "Add new connection" page. A red callout box says "Enter 'Flight' in the Search box to search for and select 'FlightSQL'." A yellow hand icon points to the search input field containing "flight". Another red callout box says "Select 'Install via Grafana.com' to install the FlightSQL plugin." A yellow hand icon points to the "FlightSQL" entry in the "Data sources" list.
- Bottom Screenshot:** Shows the "FlightSQL" plugin details page. A red callout box says "Select 'Install via grafana.com' to install the FlightSQL plugin." A yellow hand icon points to the "Install via grafana.com" button.

**“FlightSQL” Plug-in installation.**

**“FlightSQL” has been installed.**

**From the “Add new connection” screen, click on “FlightSQL” to begin with “Data source” configuration.**

**Click on “Create a FlightSQL data source”.**



**FlightSQL Connection Configuration**

Host-Port: us-east-1-1.aws.cloud2.influxdata.com:443  
 Auth Type: token  
 Token: configured  
 Require TLS / SSL:

**MetaData**

Key	Value
bucket-name	BMP280_Bucket

**Query Configuration**

```
FROM sensor_data
SELECT time, temperature, pressure
WHERE value = value
```

**Query Inspector**

Refresh

**Data**

time	temperature	pressure
168946804210	30.257210072834276	1002.0867330002187
16894685904921	30.39762377535319	1002.1297021863173
1689468205596	30.346704493394007	1002.101183549715
1689468506230	30.3402238597286	1002.1427480007485
168946806792	30.37509584679001	1002.1568037704693

Specify the Host as recorded in Worksheet 3.6.1 (10) as URL with “:443” as the port to be used.  
 Select “token” as the Auth Type, and enter the Token information (12) that you have already written down.  
 In the MetaData field, specify “bucket-name” for Key and Bucket name (11) for Value.

Press “Save & test” to confirm the configuration. Check the configuration in the Explore view.

Select “sensor\_data” for FROM, “time”, “temperature” and “pressure” for SELECT and press the “Inspector” button.

Press “Refresh” in the “Query” tab.

The results of the inspection in the “Data” tab show the data retrieved from InfluxDB.

## STEP 3: Create a graph on the Dashboard

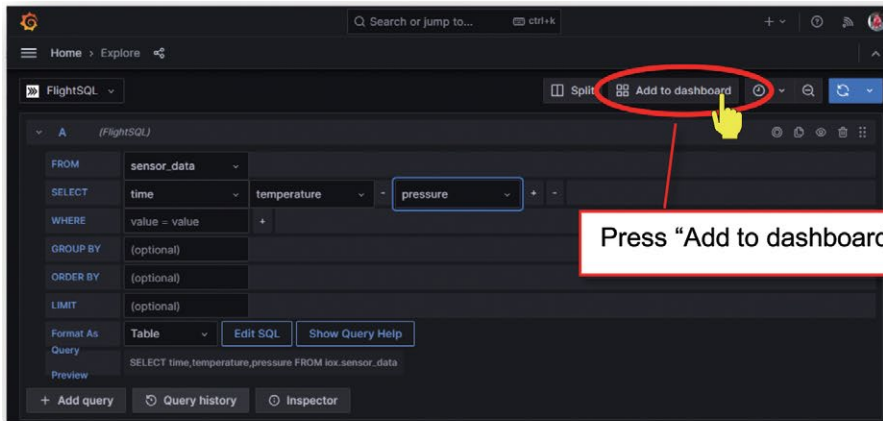

Press "Add to dashboard" button.

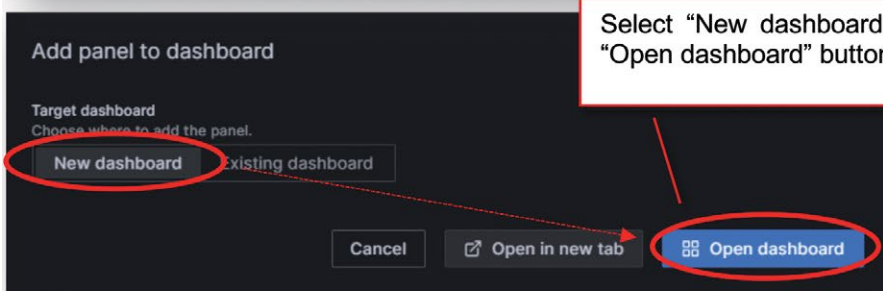

Select "New dashboard", then press "Open dashboard" button.



New dashboard is created.

Continue to add graphs by selecting "Add" ⇒ "Visualization".

## SECTION 4 LEARN THE TECHNOLOGY FOR DIGITAL KAIZEN

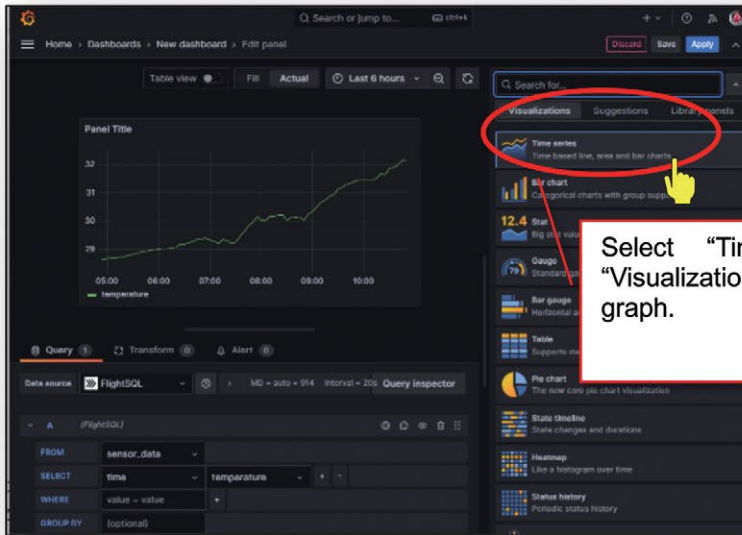

Select "Time Series" from the "Visualization" tab to display a line graph.

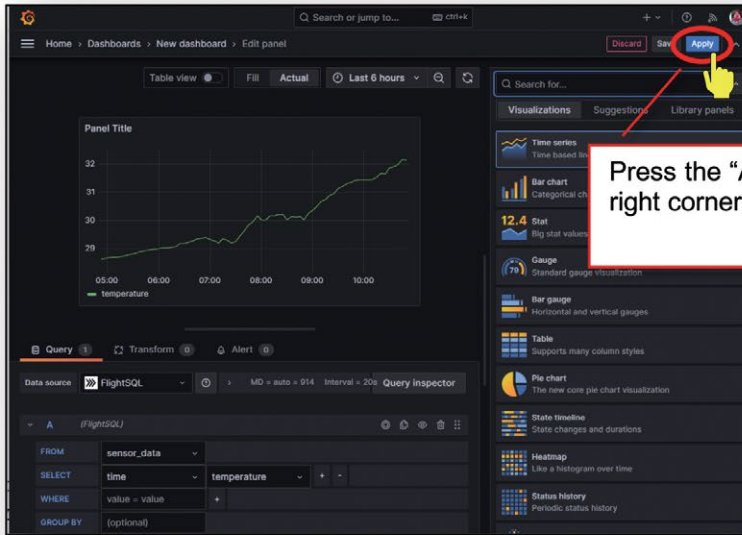

Press the "Apply" button in the upper-right corner.

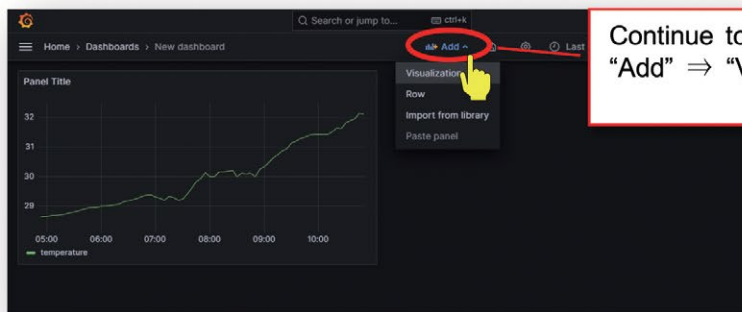

Continue to add graphs by selecting "Add" ⇒ "Visualization".



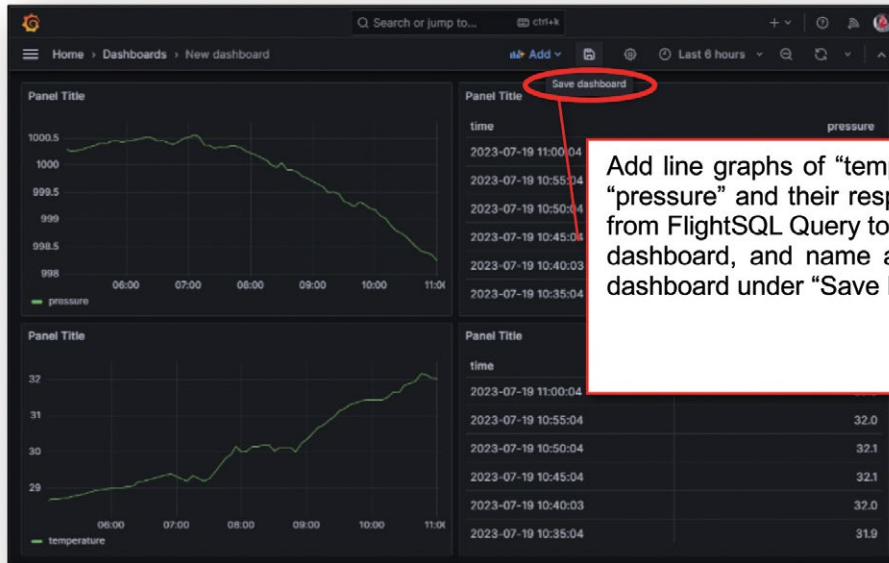

Add line graphs of “temperature” and “pressure” and their respective tables from FlightSQL Query to complete the dashboard, and name and store the dashboard under “Save Dashboard”.

The 'Save dashboard' dialog box is shown with the following details:

- Dashboard name:** BMP280\_Dashboard
- Folder:** General
- Buttons:** Cancel, Save

The 'Save' button is circled in red, and a yellow hand cursor is pointing to it.

In this example, it is stored as “BMP280\_Dashboard” shown in Worksheet 3.7.1 (18).

### STEP 4: Add alerts

This functionality allows various integrations with an SNS such as Slack, Telegram, and Line using Webhook, in addition to e-mail.

Here, as the simplest example, the following steps below show how to set up an e-mail alert on the temperature graph on the Grafana dashboard when the threshold is exceeded.

#### Create Alert Rules:

From the top Toggle Menu ☰ of Grafana, select "Alerting" in "Alerts & IRM" section and set the notification information.

From the "Alerting" screen, select "Manage Alert rules" to create a new threshold for Temperature.

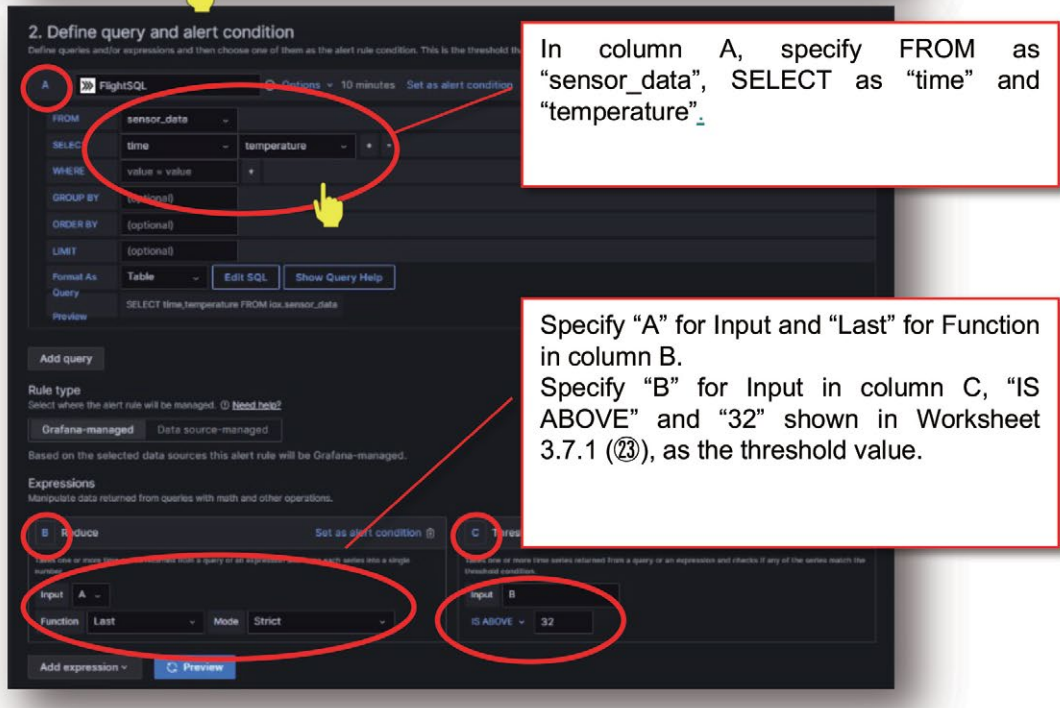
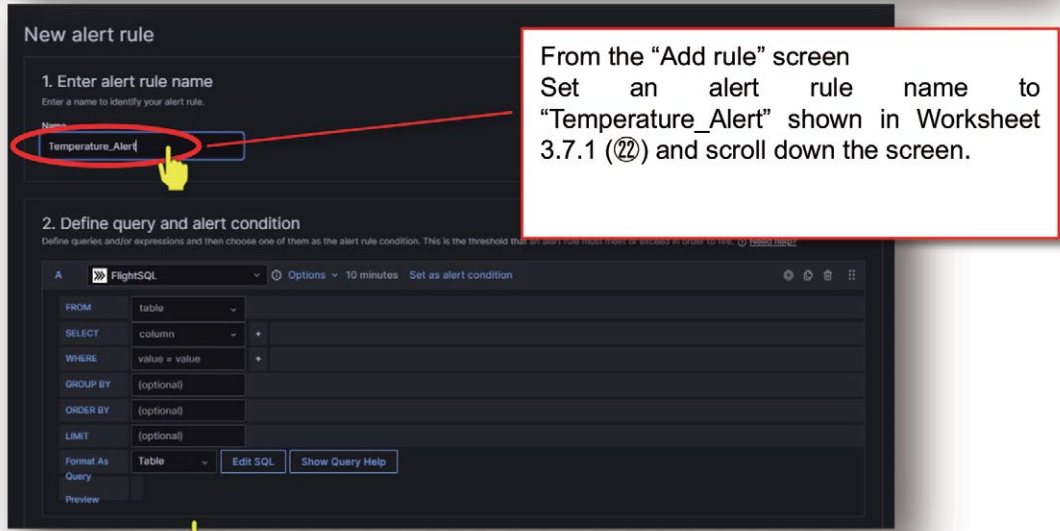
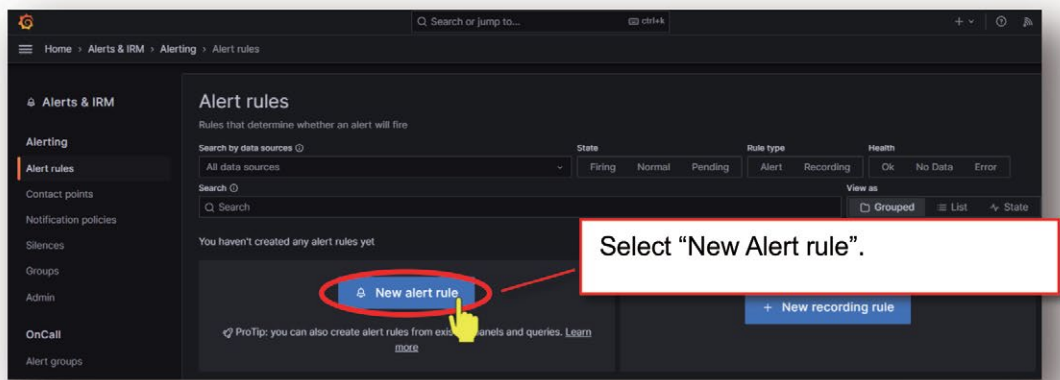

**3. Set evaluation behavior**  
Define how the alert rule is evaluated. [Need help?](#)

**Folder**  
Select a folder to store your rule.  
GrafanaCloud

**Evaluation group**  
Rules within the same group are evaluated sequentially over the same time interval.  
Temp\_Alert

All rules in the selected group are evaluated every 5m.

**Pending period**  
Period in which an alert rule can be in breach of the condition until the alert rule fires.  
5m

Pause evaluation

> Configure no data and error handling

**New evaluation group**

Create a new evaluation group to use for

**Evaluation group name**  
Temp\_Alert

**Evaluation interval**  
How often is the rule evaluated. Applies to every rule within the group.  
5m

Cancel Create

In the “3. Set evaluation behavior” section, select “Grafana Cloud” for Folder and press “New evaluation group”.

Then, create “New evaluation group” named “Temp\_Alert” with “5m” evaluation interval.

### 4. Add annotations

Add annotations to provide more context in your alert notifications. [Need help?](#)

**Summary (optional)**  
Short summary of what happened and why.



High Temperature Alert

**Description (optional)**  
Description of what the alert rule does.

Enter a description...

**Runbook URL (optional)**  
Webpage where you keep your runbook for the alert.

https://

**Dashboard UID (optional)**  
RaspBerry\_Pi\_InfluxDB\_Cloud [Temperature](#)  

**Panel ID (optional)**

[+ Add custom annotation](#)

In the "4. Add annotations" panel, Press the "Edit"  Button on "Dashboard UID(optional)", and select "BMP280\_Dashboard" shown in Worksheet 3.7.1 (18) and Panel "Temperature", then "Confirm."

Select dashboard and panel

BMP

BMP280\_Dashboard

Temperature

Cancel

Home > Alerts & IRM > Alerting > Alert rules > New alert rule

[Save rule and exit](#)

**3. Set evaluation behavior**  
Define how the alert rule is evaluated. [Need help?](#)

**Folder**  
Select a folder to store your rule.

Temp\_Alert or [+ New folder](#)

**Evaluation group**  
Rules within the same group are evaluated sequentially over the same time interval.

Select an evaluation group... or [+ New evaluation group](#)

**Pending period**  
Period in which an alert rule can be in breach of the condition until the alert rule fires.

5m

[Configure no data and error handling](#)

Select "Save rule and exit" in the upper-right corner.

### Create Contact Points:

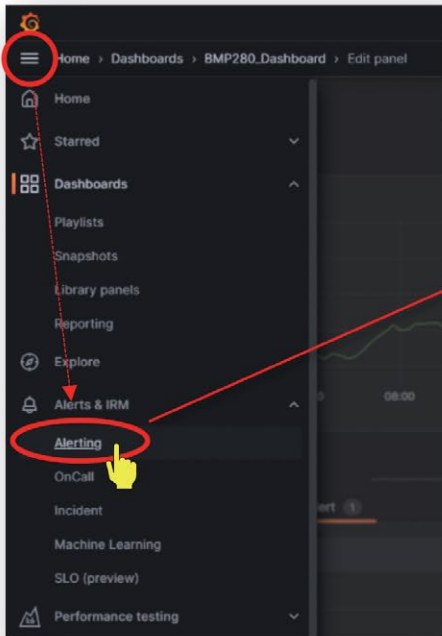

Again, from the top Toggle Menu ☰ of Grafana, select "Alerting" in Alerts & IRM, and set the information to be notified.

From the "Alerting" screen, select "Manage contact points" and create a new contact point for e-mail.

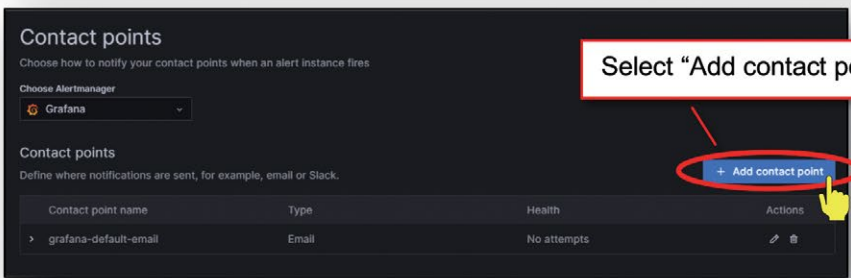
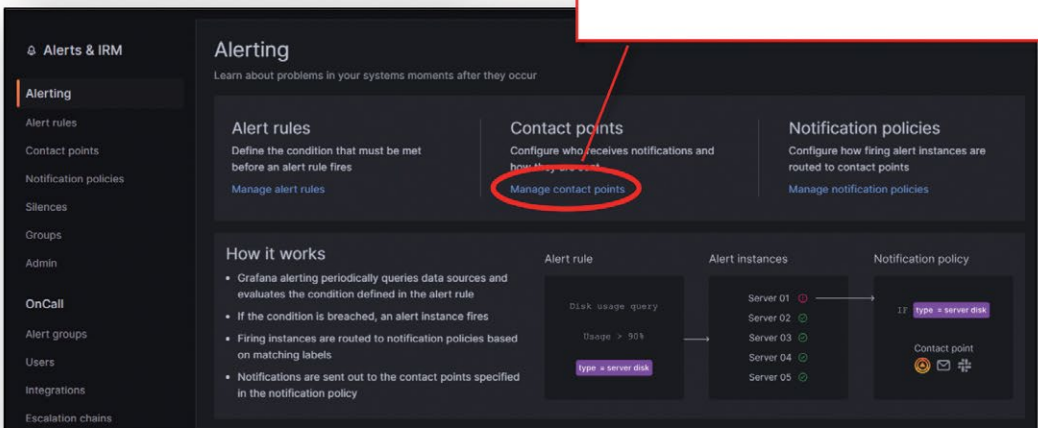

Select "Add contact point".



**Contact points**  
Choose how to notify your contact points when an alert instance fires

Create contact point

Name \*  
Mail\_Alert

Integration  
Email

Addresses  
You can enter multiple email addresses using a ",", ";" or "+" separator  
kuripapa1@gmail.com

▶ Test Duplicate Delete

Set the Name as "Mail\_Alert" (24) and the Integration as "Email".

Fill in the e-mail address to which the alert will be sent in the Address field and press the "Test" button.

[FIRING:!] TestAlert Grafana

Grafana -grafana@kuripapa1.grafana.net-  
12:40

宛先: kuripapa1@gmail.com

Grafana

Grouped by

alarmname=TestAlert instance=Grafana

1 firing instances

Instance	Status	Alert Name
TestAlert	Firing	Grafana

Summary

Notification test

Labels

alarmname	TestAlert
Instance	Grafana

Silence

Observed 0s before this notification was delivered, at 2023-11-05 03:40:32.190088627 +0000  
UTC m=>+117892.958342436

© 2023 Grafana Labs. Sent by Grafana v10.3.0-62838.

Confirm that the test message is sent to the specified e-mail address from Grafana service.

Disable resolved message  
Disable the resolve message [OK] that is sent when alerting state returns to false

+ Add contact point integration

Save contact point Cancel

Press "Save contact point" to save the settings.

Create notification policies:

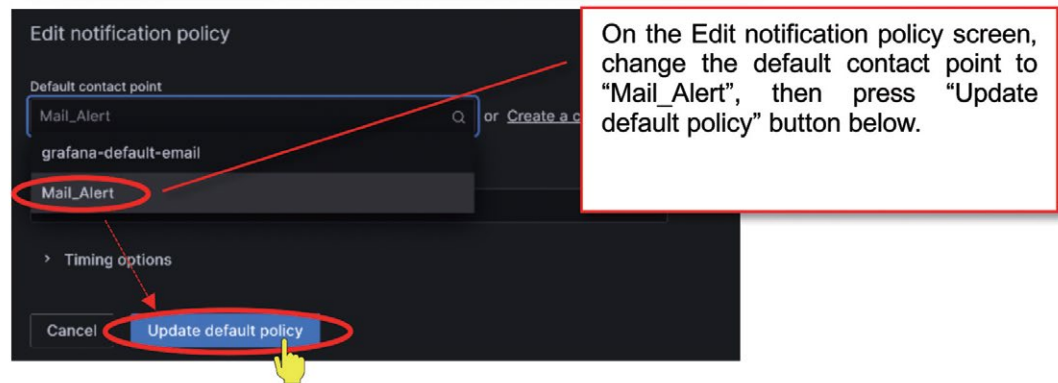
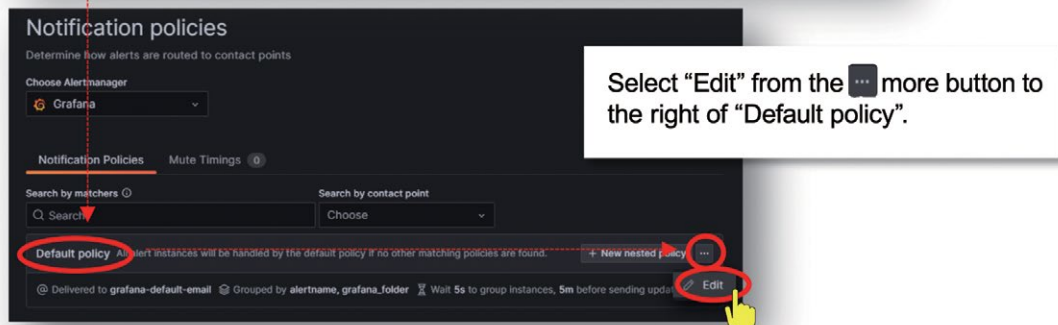
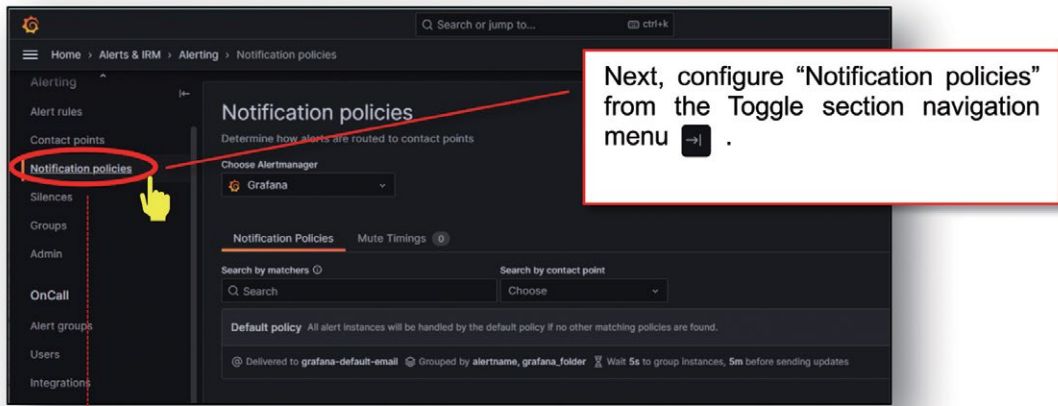

In this case, change the "Default policy" and set up the notification to be sent to "Mail\_Alert".



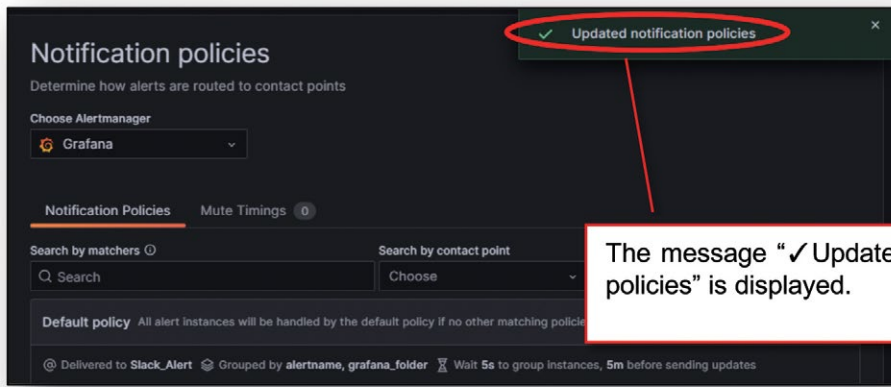

The message "✓ Updated notification policies" is displayed.

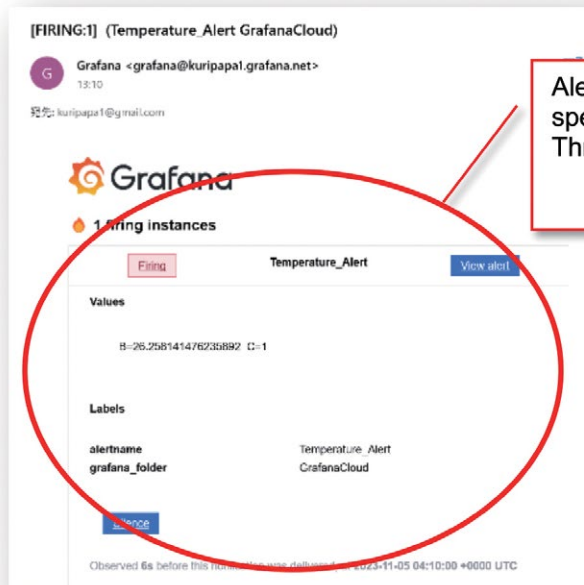

Alert notifications are initiated to the specified e-mail address when the Threshold is exceeded.

**Worksheet 3.7.1**

Exercise Worksheet				
Section	No.	Item	specified value	Example in the case
3.7.1	①	Dashboard Name		BMP280_Dashboard
	②	Slack Workspace Name		RaspBerry Pi Test
	③	Slack Post to Channel Name		Raspberrypi-test-channel
	④	Slack Weshook URL		---
	⑤	Alert Rule Name		Temperature_Alert
	⑥	Alert Threshold		32
	⑦	Alert Contact Point Name		Slack Alert

**Summary of this chapter**

✓ **Understood how to visualize and send alerts with InfluxDB Cloud and Grafana Labs.**

**Chapter 4.7 Anomaly Detection Using Sensors**

✓ **In this Chapter, we will learn about the following.**

- 4.7.1 Importance of Anomaly Detection in Kaizen**
- 4.7.2 Creating a Motor Anomaly Detection System**
- 4.7.3 Driving a DC Motor by PWM**
- 4.7.4 Connecting the motor, current sensor INA219, and the Raspberry Pi**
- 4.7.5 Anomaly Detection Strategy**
- 4.7.6 Python Programming of the Anomalies Detection System**

**4.7.1 Importance of Anomaly Detection in Kaizen**

We have observed one typical case of anomaly detection, specifically by sensing motor current in Chapter 3.5.

As this case shows, anomaly detection is a key component of jidoka (autonomation). It allows for early identification and correction of problems within the production process, ensuring quality and efficiency and fostering a culture of continuous improvement.

In addition, AI can contribute to advanced anomaly detection. In many cases, it is difficult to identify the “normal” state of production numerically. Engineers have long relied on conventional statistics to do this. However, new AI techniques are now being introduced, making identification processes easier.

Although we do not use AI techniques in the following section, keep in mind that anomaly detection using new technologies is gaining importance in kaizen initiatives.

**4.7.2 Creating a Motor Anomaly Detection System**

In this example, we will create a simple motor anomaly detection system by connecting a current sensor to a Raspberry Pi and measuring the electrical current running across the motor.

The diagram of this system is shown below.

An external power source powers the motor because a motor generally consumes a large amount of current. It is not desirable to drive a mechanical system directly with the Raspberry Pi, which does not have enough power to drive it.

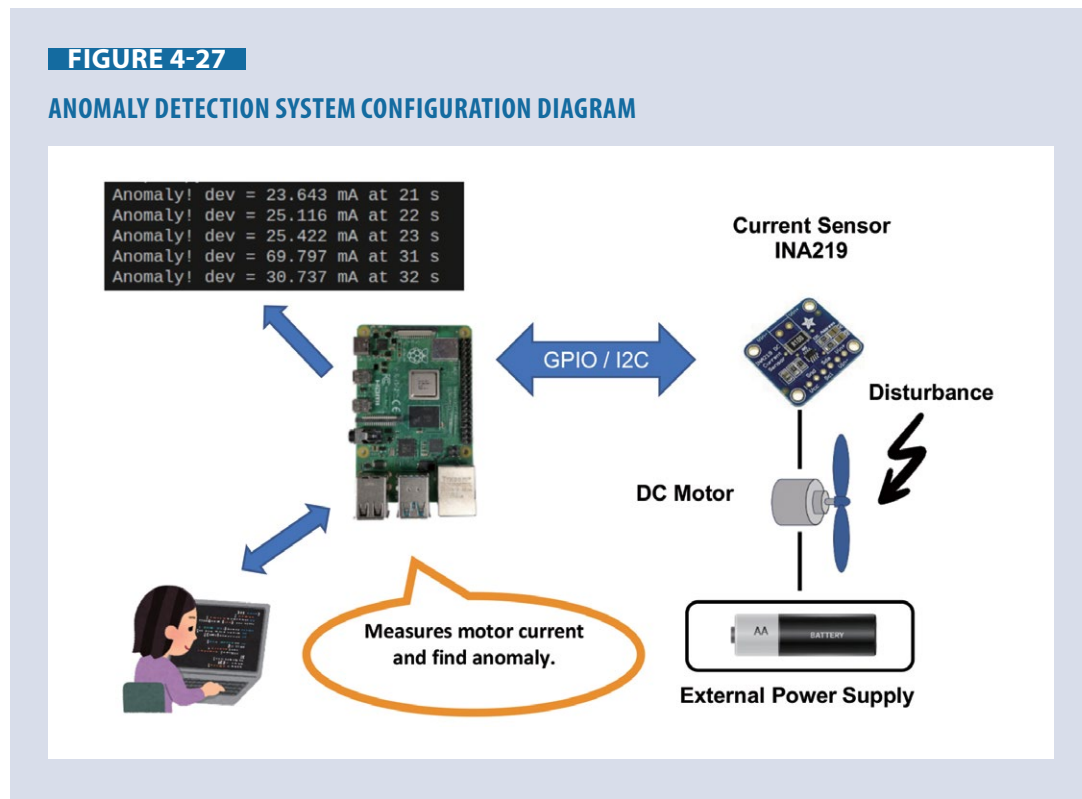

We utilize a sensor module using INA219 (Texas Instruments) to measure current across the motor. The sensor communicates with the Raspberry Pi using the I2C interface.

To simulate motor anomalies, we apply external disturbances, holding the motor shaft by hand. If external disturbances are applied to the motor, it slows down, increasing the current across it.

A Python program controls those devices and detects anomalies, namely the current increase due to external disturbances.

#### 4.7.3 Driving a DC Motor by PWM

We drive the DC motor by the PWM (pulse width modulation) [84] outputs of the Raspberry Pi.

PWM is a technique used to control the power delivered to an electrical device by varying the pulse width in a pulse train. The longer the pulse, the more power is delivered.

As Figure 28 shows, the duration of one cycle is called "period." The pulse width means the duration where the signal level is high.

**FIGURE 4-28**

**PWM**

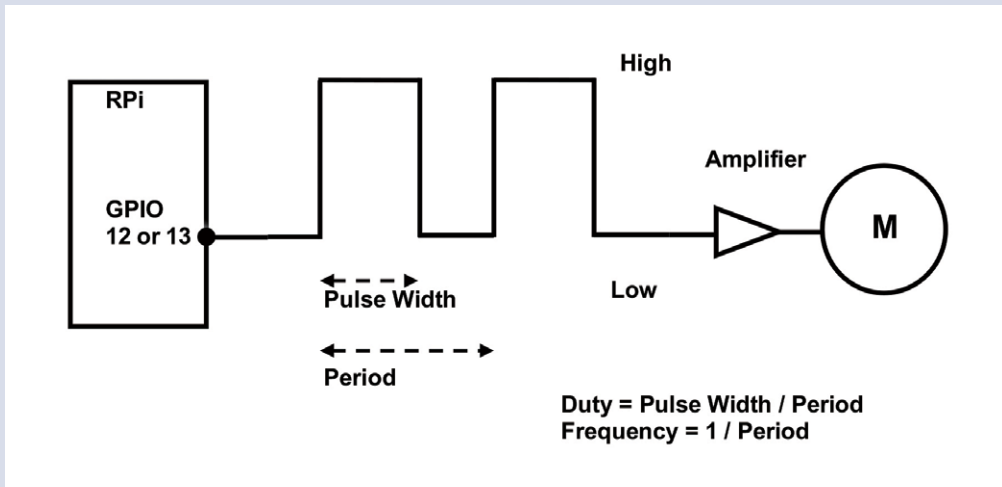

The frequency, how many times the cycles are repeated within one second, is defined as 1 / period. The duty is defined as pulse width divided by period, expressed in percentage.

GPIO 12 and 13 of the Raspberry Pi are allocated for PWM signals. We use GPIO 13 in this example.

**4.7.4 Connecting the motor, current sensor INA219, and the Raspberry Pi**

- INA219 Specifications [85]

Sensor Module

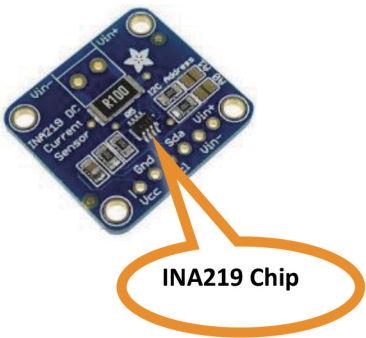

- Power supply voltage: 3.3 V to 5 V
- Maximum measurement voltage: MAX+26VDC
- Maximum measuring current: ±3.2 A
- Range: 4 ranges selectable
- Logic level: TTL (3-5 V)
- Communication Format: I2C  
(pull-up resistor included)
- Address: 0x40, 0x41, 0x44, 0x45  
(selectable by jumper)
- Current consumption: 1 mA max.

- Connection Diagram

**FIGURE 4-29**  
**CONNECTION DIAGRAM OF THE ANOMALY DETECTION SYSTEM**

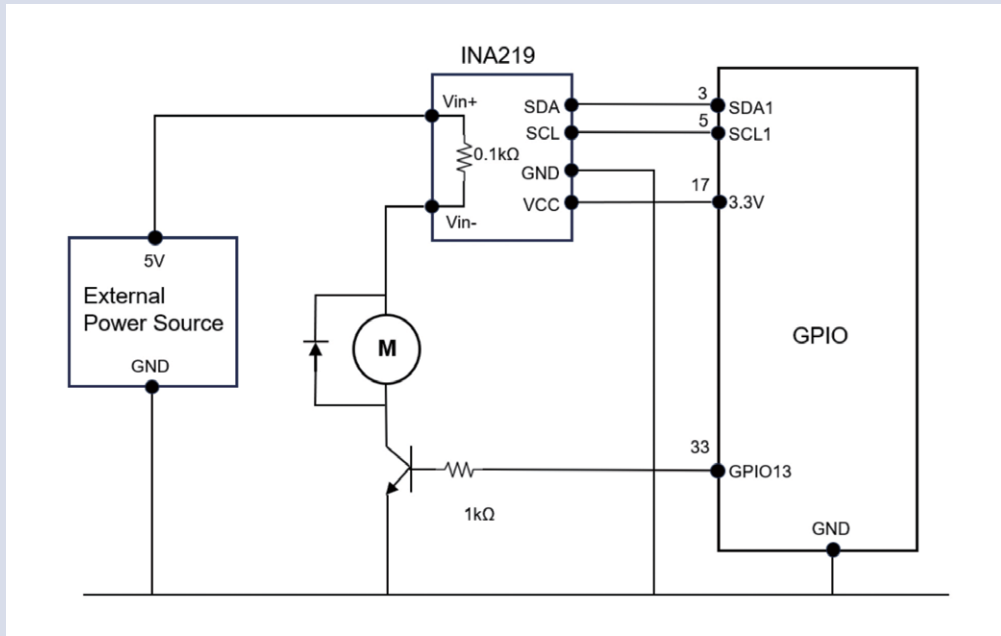

#### 4.7.5 Anomaly Detection Strategy

##### STEP 1 Measuring the normal state of the motor

This example system simulates an actual motor operation in a factory by driving it with 50% PWM duty and 80% PWM duty alternately. In other words, the motor has two states: running with 50% PWM duty (Low\_State) and 80% PWM duty (High\_State).

Figure 30 shows that each state lasts about 10 seconds and transitions to the other.

**FIGURE 4-30**  
**MEASUREMENT WITHOUT ANOMALY**

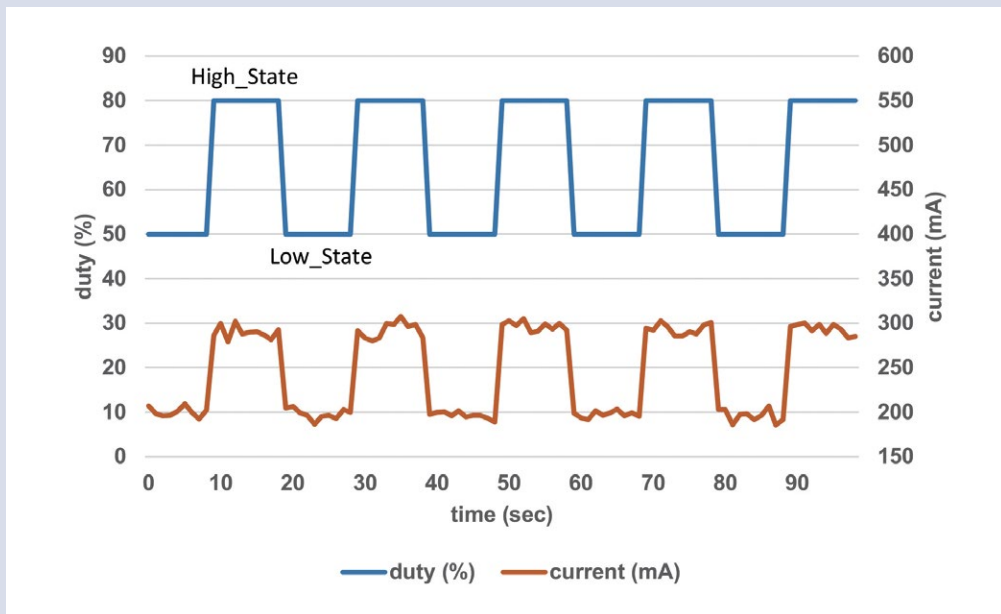

The data shown Figure 30 were taken when there were no external disturbances and the fan rotated freely.

Note that the data forms a jagged line because of the effect of the PWM signals turning on and off rapidly and the motor's electric characteristics.

### STEP 2 Defining the alert criterion

Given the data we obtained, we can calculate each state's average current value and SD (standard deviation). In this specific case, we figured the average and SD as follows.

At Low\_State (50% duty): the average current = 201.9 mA, and the SD = 7.83 mA

At High\_State (80% duty): the average current = 298.0 mA, and the SD = 12.62 mA

We define these values as describing the "normal" state of the motor. If measured current values deviate from these values, we suspect something wrong might be happening. To do this, we need a specific threshold to determine the abnormality. We put it as  $2.0 \times \text{SD}$ . Namely, if the deviation exceeds two times SD, we conclude it is an abnormal state.

- The criterion of alert: If a measured current value  $> 2 \times \text{SD}$ , generate an alert.

**STEP 3 Results of the experiment**

A Python program described later does this job. Below is the result of one experiment.

**FIGURE 4-31**  
**MEASUREMENT WITH ANOMALIES**

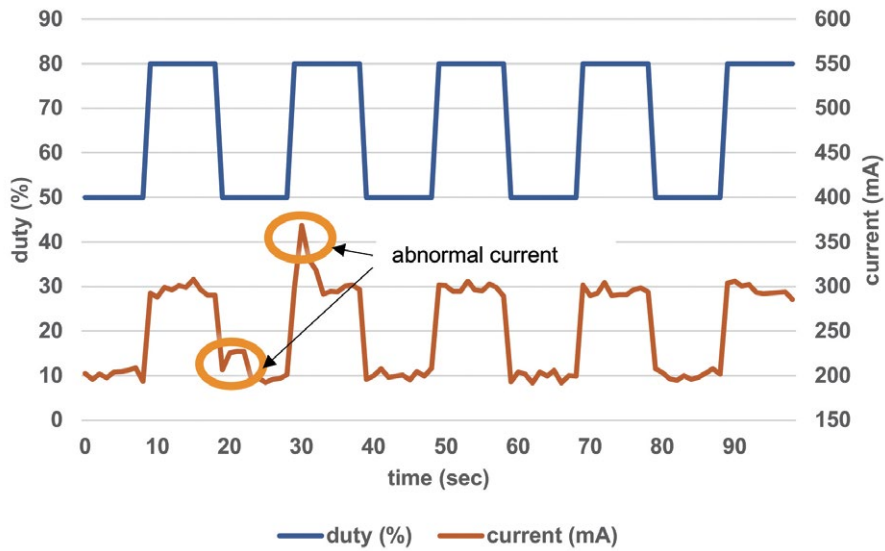

As this graph shows, we can find two distinct anomalies at time = 22 sec and time = 31 sec. The first occurred in Low\_State (PWM duty = 50 %) and the second in High\_State (PWM duty = 80 %).

Figure 32 shows normalized current data using the following formula:

- normalized current = (measured current – average) / SD



**FIGURE 4-32**  
**NORMALIZED CURRENT DATA**

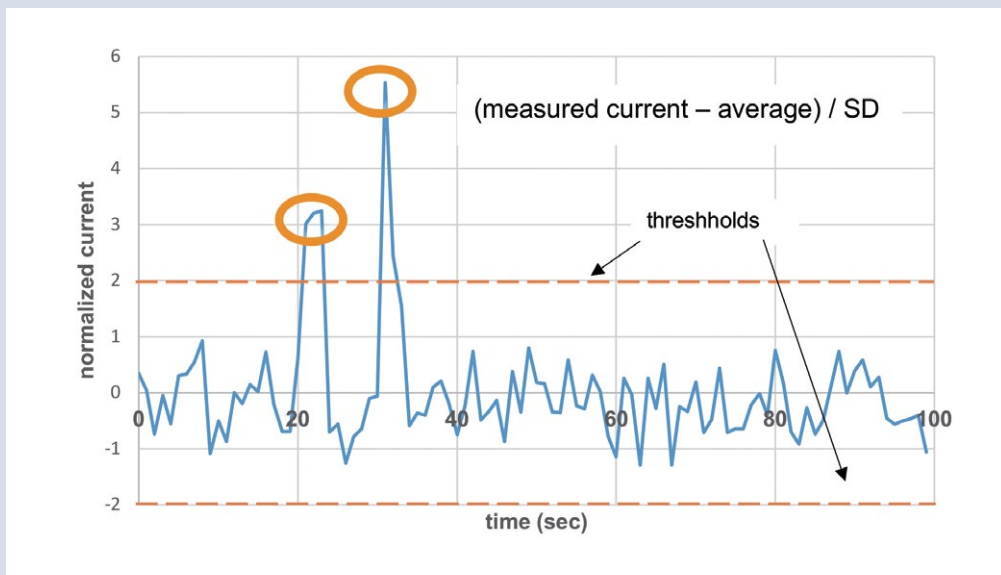

With the formula above, the Python program can calculate how far the current deviates from the normal value and determine whether it is an anomaly.

As shown below, the Python program detected these anomalies and sent alerts to the screen.

```
Anomaly! dev = 23.643 mA at 21 s
Anomaly! dev = 25.116 mA at 22 s
Anomaly! dev = 25.422 mA at 23 s
Anomaly! dev = 69.797 mA at 31 s
Anomaly! dev = 30.737 mA at 32 s
```

#### 4.7.6 Python Programming of the Anomalies Detection System

##### STEP 1: Install necessary libraries

First, install a library for using GPIO.

Enter and execute the following command from the terminal.

```
sudo pip3 install RPi.GPIO
```

Next, install a library for using INA219.

```
sudo pip3 install pi-ina219
```

##### STEP 2: Coding

- **Overview of the program**

- **Lines 62 - 91**

- This program simulates operation cycles using a motor in a factory, repeating a set of Low\_State and High\_State five times. Each state lasts about ten seconds.

- **Lines 82-91**

- The current across the motor is measured ten times at one-second intervals during each state.

- **Lines 43-55**

- At each measurement, the INA219 senses the current one hundred times, and the average of them is taken to smooth fluctuating values.

- **Lines 82-91**

- If a measured value exceeds two times the standard deviation, an alert is displayed in the console.

- **Lines 40, 85**

- The data are saved to the file “data.csv”.

```

1  # This program measures the current of a motor using INA219.
2
3  # import necessary libraries
4  import RPi.GPIO as GPIO
5  from ina219 import INA219
6  from ina219 import DeviceRangeError
7  import time
8
9  # define constants
10 SHUNT_OHMS = 0.1 # shunt resistor value in ohms for INA219
11 PWM_PIN = 13 # GPIO pin number for PWM
12 LOW_DUTY = 50 # duty cycle for LOW_STATE (low speed)
13 HIGH_DUTY = 80 # duty cycle for HIGH_STATE (high speed)
14 OPERATION_CYCLES = 5 # number of operating cycles
15 MEASUREMENT_REPEATS = 10 # number of measurements in a state
16
17 # Low_State Parameters
18 LOW_AVE_CURRENT = 201.91 # average current in mA in Low_State
19 LOW_SD = 7.83 # standard deviation in Low_State
20
21 # High_State Parameters
22 HIGH_AVE_CURRENT = 298.9 # average current in mA in High_State
23 HIGH_SD = 12.62 # standard deviation in High_State
24
25 # setup function
26 def setup():
27     # setup ina219
28     global ina
29     ina = INA219(SHUNT_OHMS)
30     ina.configure()
31
32     #set GPIO
33     global pwm
34     GPIO.setmode(GPIO.BCM) # GPIO numbering is based on BCM
35     GPIO.setup(PWM_PIN, GPIO.OUT) #
36     pwm = GPIO.PWM(PWM_PIN, 100) # PWM frequency = 100 Hz
37
38     # open data file
39     global f
40     f = open("data.csv", "w")
41
42 # read current function and return current in mA
43 def read_current(n): # n is the number of repeats for averaging
44     global ina
45     try:
46         sum = 0.0
47         for i in range (0, n):

```

```

48         # read shunt voltage and add to sum
49         shunt_voltage = ina.shunt_voltage()
50         sum += shunt_voltage
51
52         ave = sum / n # calculate average
53         amp = ave / SHUNT_OHMS # calculate current
54         #print("Amp: %.3f mA" % amp)
55         return amp
56
57     except DeviceRangeError as e:
58         print(e)
59
60 # main function
61 setup()
62
63 # start operation cycles
64 # set of Low_State and High_State is repeated 10 times
65 # one cycle: 10 sec of Low_State and 10 sec of High_State
66 for i in range(0, OPERATION_CYCLES * 2):
67     duty = average = sd = 0.0
68     if (i % 2) == 0:
69         # motor is in Low_State
70         duty = LOW_DUTY
71         average = LOW_AVE_CURRENT
72         sd = LOW_SD
73     else:
74         # motor is in High_State
75         duty = HIGH_DUTY
76         average = HIGH_AVE_CURRENT
77         sd = HIGH_SD
78
79     pwm.start(duty) # apply duty cycle to motor
80
81     # repeat measurement 10 times in a state
82     for j in range(0, MEASUREMENT_REPEATS):
83         time.sleep(1)
84         current = read_current(100)
85         f.write(f"{duty}, {current}\n") # write data to file
86
87         # anomaly detection
88         deviation = current - average
89         if abs(deviation) > 2 * sd:
90             print(f"Anomaly! dev = {deviation:.3f} mA\
91                   at {i * MEASUREMENT_REPEATS + j} s")
92
93 f.close()
94
95 GPIO.cleanup(PWM_PIN)
96 print("done")

```

# SECTION 5 HOW TO PROCEED WITH A PROJECT

The goals of this section are:

- To be able to propose and give advice to client companies on “how to proceed with system development when conducting kaizen activities that incorporate digital technology (Digital Kaizen).”
- To understand the framework of the agile project management methodology “Scrum,” and how to apply the tools used in the methodology.
- To understand the matters to be confirmed at each stage of a project, and how to prepare output materials.

This chapter first introduces the basic concept of how to proceed with a project when conducting kaizen activities that incorporate digital technology (hereinafter referred to as Digital Kaizen) as opposed to traditional kaizen activities (hereinafter referred to as Analog Kaizen). Then, the framework of “Scrum,” a project management methodology suitable for Digital Kaizen, which is currently the mainstream of agile project management methodologies, will be introduced along with how to apply the various tools used within the framework. Finally, we will introduce the materials that should be prepared after a project is completed.

## Chapter 5.1 How to Proceed with a Project Suitable for Digital Kaizen

Kaizen activities are activities aimed at increasing productivity by eliminating muri (overburdening), muda (waste), and mura (unevenness) in daily business operations. The key aspects in promoting these activities are that each on-site worker brings their own ideas and proactively participates in the activities, that everyone from management to on-site workers cooperates as one team irrespective of their different positions, and that they keep making a continuous effort in accumulating small kaizen improvements through repeated trial and error.

Even if these kaizen activities are switched to Digital Kaizen, the fundamental concept remains the same. The difference between “Digital Kaizen” and “Analog Kaizen” is that Digital Kaizen makes use of digital technology such as IoT, enabling the utilization of information that has previously been difficult to obtain with Analog Kaizen. Having access to such information makes it possible to discover and eliminate muri, muda and mura in operation, which were previously impossible to grasp.

Taking it one step further, Digital Kaizen also includes increasing productivity through the automation of devices based on AI-based analysis and acquired data. Hence, Digital Kaizen involves the same “kaizen” activities as Analog Kaizen, which means that the approach to Digital Kaizen can be the same as that for Analog Kaizen activities.

On the other hand, however, Digital Kaizen involves system development using new digital technologies such as IoT devices, programming, cloud computing, and AI, which up until now have not been utilized in kaizen activities. In Digital Kaizen, it is therefore advantageous to incorporate a project management methodology suitable for system development.

**FIGURE 5-1**  
**THE DIFFERENCE BETWEEN ANALOG KAIZEN AND DIGITAL KAIZEN**

	Analog Kaizen	Digital Kaizen
Goal	Eliminate muri, mura, and muda in business operations and increase productivity.	
Policy	<ul style="list-style-type: none"> <li>• Proactive approach</li> <li>• Ingenuity and inventiveness</li> <li>• One team</li> <li>• Trial and error</li> <li>• Continuous efforts</li> </ul>	
Methods of identifying problems	Problems identified mainly through analog methods. <ul style="list-style-type: none"> <li>• Through visual observation</li> <li>• Through the use of tools such as stopwatches</li> </ul>	Problems identified using digital technology. <ul style="list-style-type: none"> <li>• Through measurement with IoT sensors</li> </ul> Through analysis using IT
Methods of Kaizen	Kaizen using mainly analog methods (e.g.) <ul style="list-style-type: none"> <li>• Reallocation of production lines</li> <li>• Changes in worker assignments</li> </ul>	Kaizen using digital methods. (e.g.) <ul style="list-style-type: none"> <li>• E-mail notifications based on acquired data</li> <li>• Air conditioning adjustments based on acquired data</li> </ul>

There are two ways to proceed with a system development project: the waterfall approach and the agile approach.

In the waterfall approach, system development is divided into the processes of “requirement definition,” “design,” “development,” “testing,” and “release,” and project progress is managed by completing one process before moving on to the next. As the name “waterfall” implies, this is a methodology in which system development moves from upstream to downstream processes like the flow of a waterfall, and it is basically assumed that there will be no backtracking.

Its advantages are that it is easy to plan the manpower required for each process as development work doesn’t start until after the content of development is clarified in the initial “requirement definition” phase of the project, and that it is easy to grasp the progress of the project since the plan up to the release is established at the start of the project.

On the other hand, the methodology has a disadvantage in that it is not possible to see the system in action until the final stage of system development, and if the finished system is different from what was envisioned, it is difficult to go back and make changes. This is because any changes would collectively affect the design, development, and testing processes, resulting in a large amount of work to be redone, which would increase costs and lengthen the development period.

In contrast, in the agile approach, the system is divided into functional units, and the “requirement definition,” “design,” “development,” “testing,” and “release” processes are all performed within a short period of time (one to four weeks) to complete a working system. Users can experience a working system from the beginning of the project and provide feedback to the developers [1–3].



FIGURE 5-2

## HOW TO PROCEED WITH PROJECTS USING THE WATERFALL APPROACH AND THE AGILE APPROACH

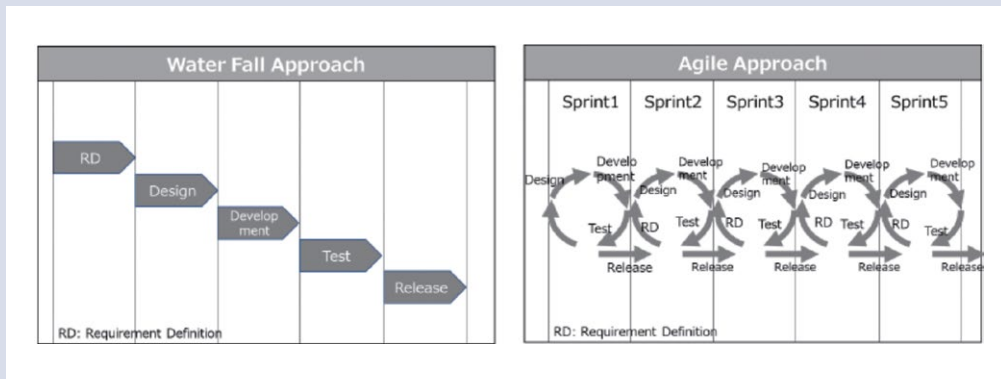

Because development proceeds function by function in short cycles, the development team can respond flexibly even if requirements change mid-project. Unlike the waterfall approach, the agile approach is an adaptive project management method that takes it for granted that modifications will be made during the project.

Since IT system development for Digital Kaizen activities involves the use of new technologies, it is necessary to proceed with system development through a process of trial and error while confirming the feasibility and effectiveness of the concept. Therefore, there is a high possibility that requirements set at the beginning of a project will be changed during the project, and the project must be able to adapt to such changes as they occur.

From this perspective, it can be concluded that a project management method following the agile approach is suitable for Digital Kaizen activities.

There are various agile project management methodologies, such as “Scrum,” “XP,” “kanban,” and “lean,” and while each methodology has some differences in practice, they all share the following characteristics:

- The practice of dividing the development target into small functional units and developing them in the order determined by user needs, starting with the functions that are needed the most.
- The practice of creating a working system within a short development cycle of one to four weeks and delivering it to the users.
- The practice of checking whether the delivered system meets the needs of users and proceeding with development while making course corrections as needed.

In 2021, a U.S. technology company “Digital.ai” conducted a survey of individuals from a wide range of industries in the global software development community, and 66% of respondents indicated Scrum as their “adopted agile methodology [4].” This suggests that Scrum is currently the most widely used methodology. Therefore, this text aims to explain how to proceed with an agile project based on the framework of Scrum [5].

## Chapter 5.2 How to Proceed with Agile Project Management

This chapter describes Scrum, which is currently the most widely used agile project management methodology, explaining its origin, characteristics, framework, project promotion structure, and how to proceed with a project, as well as presenting a concrete image of how Scrum is applied to a Digital Kaizen project.

### 5.2.1 Origins of Scrum

The origins of Scrum can be traced back to the article “The new product development game” written by Ikujiro Nonaka (Professor Emeritus at Hitotsubashi University) and Hirotaka Takeuchi (Professor at Harvard Business School) and published in the Harvard Business Review in 1986. In the article, the authors cited Canon and Honda as examples of competitive workplaces for new product development and characterized the overlapping processes of product development as “a holistic or ‘rugby’ approach—where a team tries to go the distance as a unit, passing the ball back and forth—.” The name they gave this type of development method was Scrum [6, 7].

Inspired by this article, Jeff Sutherland together with Ken Schwaber later systematized Scrum as a framework for software development and introduced it to the public in 1995. In developing the framework of Scrum, Jeff Sutherland has stated that he drew on the Toyota Production System established by Taiichi Ohno for many of its basic concepts [8].

The Toyota Production System is a production system that aims to increase productivity by practicing kaizen, and the word “kaizen” as used in the Toyota Production System has spread around the world, finding its way into the English language as well. Thus, there is a deep connection between the Scrum and kaizen, and the Scrum shares many common characteristics with kaizen.

### 5.2.2 Characteristics of Scrum

In the “Scrum Guide” (November 2020 edition), Scrum is defined as “a lightweight framework that helps people, teams and organizations generate value through adaptive solutions for complex problems [9].” The framework has many characteristics in common with kaizen. The following is a description of the characteristics of Scrum and the points that are common to kaizen.

- **Function development in small units and adaptability to change**

In Scrum, the entire system is divided into small functional units, and system development is carried out by repeating the process of building each function little by little over a short period of one to four weeks. This makes it possible to flexibly respond to changes in development requirements even if they were to arise mid-process.

Kaizen has this in common with Scrum, with the former also being an incremental activity that accumulates small improvements. Since Digital Kaizen involves taking on new challenges with new technologies, projects must proceed while continuously confirming their effectiveness through repeated trial and error. By utilizing the Scrum framework to develop systems in a small-scale and quick manner, it is possible to proceed with kaizen activities while experimenting with various methods to identify the most effective one.

- **Emphasizing team self-management**

Scrum is based on the belief that teams that have the discretion to decide how to work on their own are more productive and more adaptable to change compared to teams that work under



orders and instructions. For this reason, Scrum deliberately avoids having a leader giving instructions and orders to team members [10].

Kaizen also encourages spontaneous activities by on-site workers, based on the belief that they know best what is happening on the work site. This is another aspect where Scrum and kaizen share the same characteristics.

- **Promoting transparency and collaboration**

Scrum emphasizes transparency, allowing everyone involved to see what is being developed in a Sprint and the progress of each team member's work. Transparency allows project stakeholders to understand the contents and progress of the project, thereby facilitating communication, building trust, and encouraging collaboration and ingenuity [11, 12].

In Digital Kaizen, the involvement of diverse experts and collaboration among different departments is necessary to incorporate new IT technologies and promote kaizen activities. By increasing project transparency, sharing information, and promoting collaboration among the stakeholders involved, effective kaizen can be achieved.

- **Promoting continuous kaizen through regular review**

Scrum emphasizes empiricism and is based on the belief that knowledge comes from experience and that decision-making is based on observation. Therefore, Scrum provides teams with regular opportunities to reflect on their experiences through events such as Sprint Reviews and Sprint Retrospectives, so that they can learn about their experiences and make improvements (kaizen) [9, 12].

In kaizen as well, it is important to regularly reflect on one's activities, and to follow a cycle of continuous improvement. Scrum is distinctive in that events for continuous kaizen activities are built into its framework.

### 5.2.3 Overview of the Scrum Framework

This section provides an overview of the Scrum framework, including an overview of the division of roles within a Scrum Team and how to proceed with a Scrum project. First, we begin with an explanation of the division of roles in a Scrum Team. In Scrum, a project is conducted by a small team (generally 5 to 9 people). This team is called the Scrum Team. A Scrum Team consists of one Product Owner, one Scrum Master, and a Development Team of several people. The roles of each are as follows [13–17]:

- 1 **Product Owner:** The Product Owner is accountable for deciding the contents of the project that the Scrum Team will work on and maximizing the value of the product produced by the Scrum Team.
- 2 **Scrum Master:** The Scrum Master is accountable for the way a Scrum Team proceeds with the project and manages the whole project. However, a Scrum Master does not give orders to the team members. Rather than giving orders, a Scrum Master supports the Scrum Team members by coaching them and removing impediments so that they can self-manage and work collaboratively with other team members.
- 3 **Development Team:** These are the members who carry out the actual development. Members are responsible for completing the Product Backlog.

FIGURE 5-3

## DIVISION OF ROLES IN A SCRUM TEAM

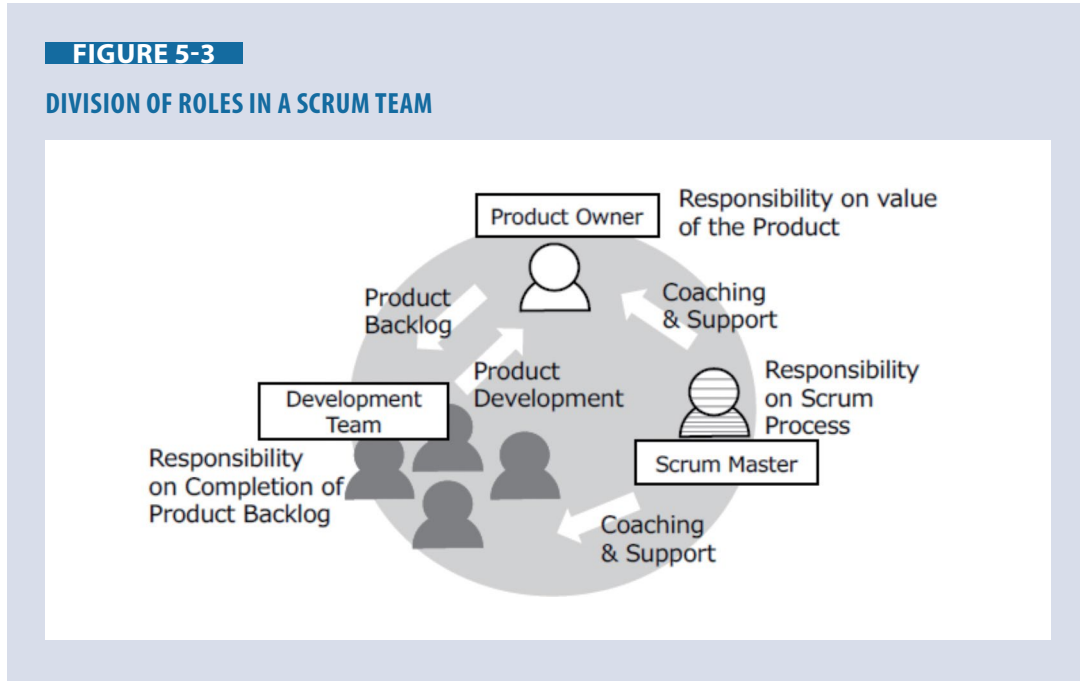

Next, we move on to an explanation of how to proceed with a project in Scrum.

In Scrum, teams work in relatively short fixed-length periods, from one to four weeks, and then repeat this process multiple times to advance the project step by step. This repeated period of work is called a Sprint. The sequence of each event is as follows:

1. Creation of a Product Backlog: Simply put, a Product Backlog is a list of features to be developed by a Sprint Team. It is created by the Product Owner prior to a Sprint.
2. Sprint: A repeated development period; the following four events are performed within one Sprint:
  - 1) Sprint Planning: A meeting to break down the features to be developed in the current Sprint into tasks.
  - 2) Daily Scrum: Meetings held during a Sprint to share information on the progress of each member's daily work and any impediments to the progress of the work within the team, and to implement kaizen measures to ensure smooth development. They are held every day at the same time and for a short period of time (15 minutes or less).
  - 3) Sprint Review: A meeting to demonstrate the results achieved during a Sprint to stakeholders and receive feedback from them.
  - 4) Sprint Retrospective: A meeting where each person reviews the activities of a Sprint, discusses what went well and what did not, and considers what needs to be improved to further increase productivity as a team.

**FIGURE 5-4**  
**HOW TO PROCEED WITH A SCRUM PROJECT**

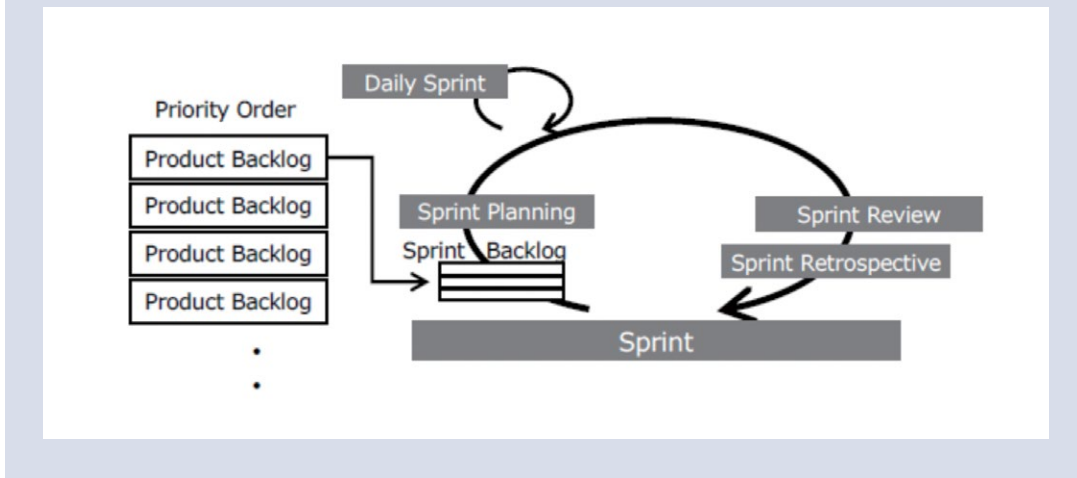

The preceding has been an overview of how to proceed with a project using the Scrum framework. The following sections will cover the specifics of the three roles that make up a Scrum Team, i.e., the Product Owner, the Scrum Master, and the Development Team, and how to proceed with a project using Scrum, while also introducing the tools used in each Scrum event. Each section is then followed by a description of how these roles, methods and tools are applied in Digital Kaizen.

#### 5.2.4 Project Promotion Structure in Scrum and an Image of How It Is Applied to Digital Kaizen

This section details the three roles that make up a Scrum Team and provides an image of how they are applied in Digital Kaizen.

##### **Product Owner**

As mentioned earlier, a Product Owner is accountable for deciding the contents of the project that a Scrum Team will work on and maximizing the value of the product produced by a Scrum Team. The main duties of a Product Owner are listed below.

- The Product Owner creates a Product Backlog which is a list of features that the project is expected to deliver.
- To create a Product Backlog, a Product Owner will engage in dialogue to accurately understand the needs of internal stakeholders, including management, in the case of internal projects for business improvement, or with external stakeholders in the case of projects for external clients.
- The Product Owner decides the order of priority of the created the Product Backlog based on business value.
- The Product Owner then presents the Product Backlog to the Scrum Team, explains to them the functionality to be achieved in the project and the business value it delivers, answers their questions, and supports them in translating the Product Backlog into concrete tasks.
- The Product Owner sets the completion criteria for the Product Backlog to be developed and determines whether the product is acceptable during the Sprint Review.

To fulfill their role as described above, the Product Owner must be able to determine which projects are most effective in creating the business value desired by the stakeholders. They must also have a good understanding of the technical aspects of the work that the Scrum Team is trying to accomplish. The Product Owner spends half of their time in dialogue with stakeholders to accurately understand their needs, and the other half interacting with the Scrum Team to help clarify requirements and provide feedback on development results prior to the Sprint Review. Therefore, the Product Owner should be as close as possible to the Scrum Team, and available for dialogue always [13–16].

- **Application to Digital Kaizen projects**

When applying the above-mentioned role of the Product Owner to Digital Kaizen, the following points should be kept in mind:

- The Product Owner should understand the situations where Digital Kaizen can help solve business issues, while at the same time having a good understanding of the on-site operations where Digital Kaizen will be implemented.
- The Product Owner does not develop the system for Digital Kaizen but should be a member of the Scrum Team and be available for conversation whenever the Development Team needs to confirm ambiguities in the requirements etc. during the development process.
- Even if system development is outsourced to a contractor, the Product Owner should come from the outsourcing party. The Product Owner should join the Scrum Team as a representative of the outsourcing party and should have a clear understanding of the needs of their company's stakeholders, which should be communicated to the outsourced contractor. Even when outsourcing system development to a contractor, Scrum emphasizes the self-management of team members and collaboration within the team, so it is important to ensure that the outsourcing party and the contractor work as one team to advance the project.

### **Scrum Master**

The Scrum Master is accountable for the way the Scrum Team proceeds with the project and plays a leadership role in managing the entire project. However, the Scrum Master does not give instructions or orders to the team members like the project manager in a project using the waterfall approach. This is because Scrum values the self-management of the Development Team members and is based on the concept of maximizing team productivity by allowing the team members to decide on their own how to proceed with their work. Therefore, rather than giving instructions and orders, the Scrum Master supports the Scrum Team members in carrying out activities through self-management and by working collaboratively with other members. This form of leadership is called “servant leadership.” The main duties of a Scrum Master are listed below.

- Acting as a facilitator in moderating meetings such as Sprint Planning and the Daily Scrum.
- Coaching the Scrum Team members so that they can work proactively and autonomously.
- Working to remove any impediments to progress to ensure maximizing productivity of the team.
- Preventing external interference so that team members can focus on their work. (e.g., acting as a point of contact for stakeholder inquiries, preventing interference from management, etc.)

To fulfill their role as described above, the most important skill required of the Scrum Master is the ability to communicate. In meetings such as Sprint Planning and the Daily Scrum, the Scrum Master will ask questions to the Product Owner and the Development Team to facilitate a deepening of the members' thinking and encourage ingenuity and inventiveness, so that the members can practice proactively and increase the productivity of the Scrum Team. The Scrum Master should also have a reasonable level of knowledge of both the business and technical aspects of the Product Backlog to assist in the dialogue between the Product Owner and the Development Team when incorporating the requirements of the Product Backlog into the Sprint Backlog [13–18].

- **Application to Digital Kaizen projects**

When applying the above-mentioned role of the Scrum Master to Digital Kaizen, the following points should be kept in mind:

- In principle, The Scrum Master should not be assigned to a person who has supervisory authority over the Development Team, such as a development team manager. This is because, as already mentioned, the role of the Scrum Master is to coach the Development Team proactively, and not to give them instructions or orders.
- However, in the case of Digital Kaizen initiatives in small and medium-sized companies, there may be cases where there is no choice but to assign the development team manager as the Scrum Master due to limited human resources. In such cases, it is important to keep in mind that even in the manager's position, they should refrain from giving orders, encourage the Development Team members to speak up their opinions, and encourage the Development Team to be proactive.
- When outsourcing system development to a contractor, it is, if possible, a good idea to select a contractor that has experience in system development using Scrum and to assign a person who already has experience as the Scrum Master to the role. If this proves difficult, inform the contractor that you wish to proceed with system development using Scrum, and encourage them to ensure that their activities follow the Scrum framework.
- In addition, when outsourcing system development, it is common for the outsourcing company to provide the Product Owner, while the contractor provides the Scrum Master and the Development Team. Even in cases such as this, it is important that the Product Owner from the outsourcing party and the contractor work together as one team.

### **Development Team**

The Development Team is a team that carries out the actual development. The Development Team usually consists of three to seven members, and each member is responsible for completing the project backlog. In Scrum, the goals to be achieved are presented in the form of the project backlog, but the method for achieving these goals and how to proceed with the work is left to the Development Team.

The Development Team actively participates in Sprint Planning, clarifying ambiguities in the requirements defined in the Product Backlog and distilling them down to tasks. In addition, the Development Team uses ingenuity and inventiveness to carry out development in the most effective way possible.

The main duties of the Development Team are listed below.

- The Development Team develops the Product Backlog items according to the priorities indicated by the Product Owner.
- In the Sprint Planning event, the Development Team breaks down the Product Backlog into concrete work items that can be completed in a single Sprint in the Sprint Planning event.
- The Development Team will carry out design, development, integration, and testing in each Sprint.
- In the Daily Scrum, the team members confirm each other's progress, share ideas, and collaborate on their work to maximize the team efficiency.
- During the Sprint Review, the Development Team presents the items developed during the current Sprint to stakeholders.
- The Development Team assists the Product Owner in grooming the Product Backlog (refining and re-prioritizing the Product Backlog) for the next Sprint.

To fulfill their role as described above, the Development Team must have the ability to self-manage and the autonomy to discuss and decide among themselves how to plan, manage, execute, and communicate. In addition, the team must be structured not by role, but as cross-functional team composed of members with various backgrounds. In other words, the Development Team must have members who are able to carry out the design, development, integration, and testing of the system. This allows for quicker activities during system development [13–17].

- Application to Digital Kaizen projects

When applying the above-mentioned role of the Development Team to Digital Kaizen, the following points should be kept in mind:

- The Development Team oversees the actual system development, so it is necessary to gather people with the proper skills for that purpose. Specifically, wide-ranging skills related to IoT devices, networking, Python, and other programming languages, and so on. It may be difficult for small and medium-sized companies to gather personnel with all these skills, so it is necessary to appoint personnel who possess even just one of these skills from within the company, while considering the sourcing of any missing skills from contractors.
- In such cases, a mixed team of internally sourced and outsourced personnel will be required to carry out development, but it should be noted that they should collaborate with each other and work together as one team, rather than having clear boundaries of responsibility drawn between them.
- In addition, if internally sourced personnel can absorb the skills of the outsourced personnel while the project is being outsourced, this will lead to development of the company's own personnel.

### 5.2.5 How to Proceed with a Project in Scrum and an Image of How it is Applied to Digital Kaizen

This section describes how to proceed with a project in Scrum and provides an image of how each process is applied in Digital Kaizen.

#### **Product Backlog**

The Product Backlog is a list of items to be worked on by the Scrum Team in a project. As mentioned previously, it is simply put a list of features to be developed. It is similar to the work done in the requirement definition phase of a waterfall project, but the contents do not need to be refined at this stage. This is because the detailed requirements are refined during Sprint Planning. The Product Backlog is usually defined in the form of a User Story as will be described later.

There is usually more than one Product Backlog. The Product Owner, through dialogue with both the stakeholders and the Scrum Team, evaluates each Product Backlog item for how well it delivers value in terms of the stakeholders' needs and whether it is feasible for the Scrum Team, and determines the best order of priority at that point in time to maximize the value generated by the project. This order of priority may change as the project progresses. Whenever the Sprint is completed, the project will have produced a tangible working product, which at that point may inspire ideas for improvements that will add more business value. In such cases, the order of priority in the Product Backlog may be switched around.

For example, in a Digital Kaizen project, the following might occur: In the first Sprint, a system was developed that allowed for the real time monitoring of assembly machine operational status. The next Product Backlog was planned to develop the means for real time monitoring of the operational status of another piece of equipment. However, with the system developed in the first Sprint making it possible to grasp the operational status of assembly machines in real time, it was found that the operation time of the assembly machines was lower than expected and that this was a bottleneck in the production line. Therefore, with the aim of minimizing assembly machine downtime, a new Product Backlog was set up and given priority, wherein sensors for current, vibration, and temperature will be added and monitored to investigate the cause of assembly machine downtime [19–23].

#### **User Story**

The User Story is a story format that describes, from the user's perspective, how the users will benefit from the value that the project will realize. The following is a commonly used format:

As “who” (type of user), I want “what” (goal or objective) because “why” (reason).

The User Story describes in detail the desired outcomes to be realized by a project, including the reasons and background. However, it does not describe how said outcomes should be achieved. The method of realization is left to the Development Team. Based on the story, the Development Team discusses how to realize the story. If there is a need for further clarification, the team turns to the Product Owner.

The following principles, which form the acronym “INVEST,” are an effective way to write user stories.

#### 1 Independent

The User Story must be independently achievable. If the User Story is dependent on other stories, it will not be possible to independently verify the completion of development in terms of the Product Backlog.



## 2 Negotiable

The User Story must be rewritable based on dialogue between the Product Owner and the Development Team. A negotiable User Story is the most important aspect of the product development process because it allows for active dialogue between the Product Owner and the Development Team, stimulating ingenuity and inventiveness. The User Story is a catalyst for dialogue between the Product Owner and the Development Team, and they work together as one team to bring the User Story to fruition.

## 3 Valuable

The User Story must, through its realization, bring actual value to the stakeholders. This is because the User Story is created based on stakeholders' needs.

## 4 Estimable

The User Story must be specific enough to allow for a concrete estimate of the workload required to complete. If the workload cannot be estimated, it is impossible to determine whether the project can be completed within the period of the Sprint. In such cases, the Sprint team will, through dialogue with the Product Owner, help develop the User Story to a concrete enough level where it can be estimated.

## 5 Small

The User Story should be small enough in scope to be completed within the period of the Sprint. Therefore, if the scope of the User Story is large, the story should be broken up and developed in multiple Sprints.

## 6 Testable

The User Story must be clearly defined in terms of how it should be judged for completion, so that it can be determined if the story is completed or not at the end of the Sprint [23–27].

- Application to Digital Kaizen projects

If the User Story concept described earlier is applied to Digital Kaizen in the manufacturing industry, for example in the case of Company A introduced in Chapter 3, the following story can be conceived:

As “the person in charge of an automotive parts manufacturing site,” I want “to grasp the operating status of assembly machines in real time” so that “when an assembly machine stops, we can immediately identify the cause of the abnormality, deal with it, and resume operation to improve production efficiency.”

In this manner, using the User Story, the Product Owner will describe the Product Backlog during the first activity of the Sprint, the so-called “Sprint Planning” event. Then, during Sprint Planning, the Product Owner and the Development Team use the User Story as a starting point for dialogue, during which the Development Team clarifies the requirements down to the task level.

## **Sprint**

The Sprint is a unit of development cycle during which the Scrum Team is active. In Scrum, a “working product” is shown to stakeholders at the completion of each Sprint to confirm that the direction of development is consistent with their needs, and development proceeds while flexibly adjusting the direction and content of development as necessary.

A Sprint is short, ranging from one to four weeks. The Sprint is repeated multiple times throughout the project period, but the length of the Sprint period is not changed once it has been determined. This is because by setting a fixed period, the team can gain an empirical understanding through experience of how fast they can work during that period and use this to improve the accuracy of their planning during the next and subsequent Sprint Planning events [28–32].

There are four events during The Sprint: “Sprint Planning” conducted at the start of the Sprint, “Daily Scrums” conducted every day during the Sprint, and “the Sprint Review” and “the Sprint Retrospective” conducted at the end of the Sprint. Each of these will be discussed in detail in the following sections.

### **Sprint Planning**

Sprint Planning is an event that takes place at the beginning of each the Sprint. All members of the Scrum Team participate in Sprint Planning.

Sprint Planning consists of two phases. The first phase, facilitated by the Scrum Master, clarifies the functional requirements to be developed, and the second phase examines how to achieve the required functionality and estimates the workload involved in achieving it.

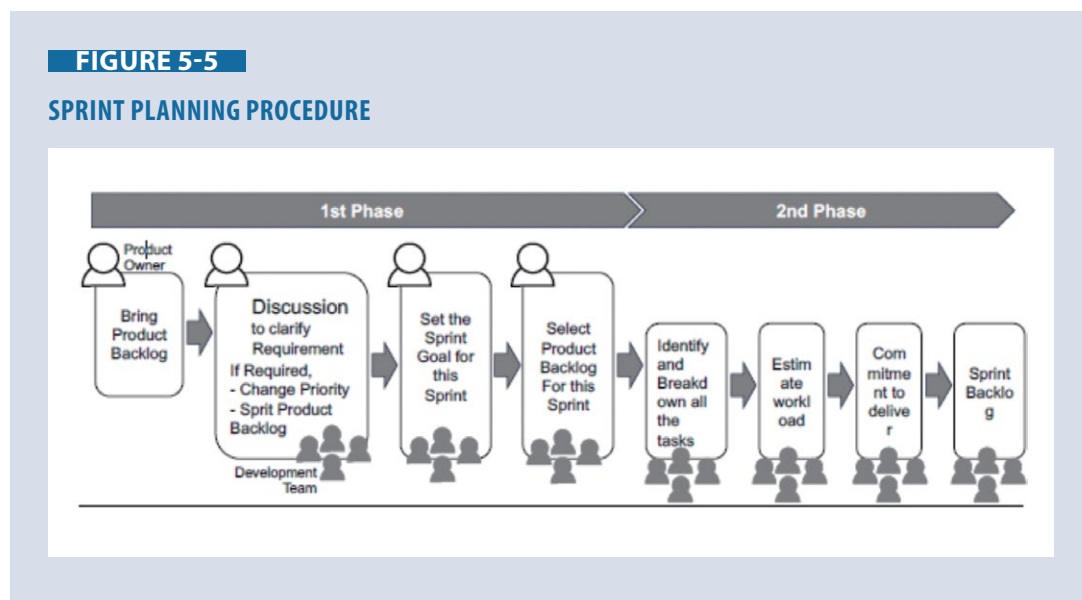

In the first phase, customer requirements are organized and the most important of the Product Backlog items that should be developed in the current Sprint are determined. First, the Product Owner describes the prioritized Product Backlog items to the Development Team in the form of the User Story.

The Development Team clarifies functional requirements by asking questions about any unclear parts of the described Product Backlog. Then, based on customer requirements and the capacity of the Development Team, the order of priority of the Product Backlog is revised as necessary, and finally, the “Sprint Goal” to be achieved in the current Sprint is determined.

During the meeting, the Scrum Master encourages reflection by asking questions of both the Product Owner and the Development Team, helping both sides improve their understanding and stimulate ingenuity and inventiveness [33–38].

Once the Sprint Goal is determined, the Product Backlog is selected that is aligned with the Sprint Goal.

In the second phase, the Development Team identifies the necessary tasks to realize the selected Product Backlog. Tasks constitute all the work required to realize the Product Backlog, including analysis, design, development, and testing, etc.

Once the tasks are identified, the next step is to estimate the workload required for each task. In Scrum, workload estimation is carried out by all development members. When estimating the workload, a set of cards referred to as “planning poker” is used. The cards are used in the following manner.

**STEP 1:** Select the task to be estimated.

**STEP 2:** All at once, the members each display a card with the number that they think is closest to the amount of work needed for that task.

**STEP 3:** If there are three or fewer different numbers among the displayed cards, the numbers are added up and their average taken as the estimated workload. If there are four or more different numbers, the persons who selected the smallest and largest number, respectively, are asked to explain why they chose them. Then, the members again each select a card and display them all at once. This process is repeated until there are three or fewer different numbers among the selected cards, upon which their average value is taken as the estimated workload, and the planning poker session moves on to the next task.

In this way, each member reports the relative workload required for each task, and if there is a gap in perception among members, they exchange opinions, and finally, the estimate is made to converge on a common perception of the workload required. The reason for using this method of estimation is that, in Scrum, the most accurate estimate is based on the perceptions of the people who carry out the actual work. In addition, by discussing estimates with the entire Development Team, misunderstandings and oversights can be avoided, and a common understanding of each task can be formed among the team members. Having all team members discuss estimates together deepens their understanding of the work handled by other members and allows work to proceed efficiently as team members can collaborate and work out arrangements among themselves even after work has commenced [39–42].

FIGURE 5-6

## ILLUSTRATION OF PLANNING POKER CARDS

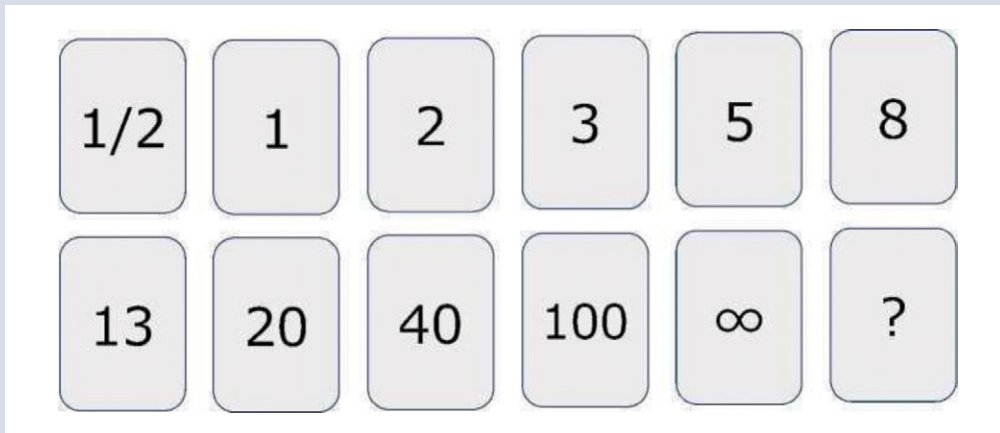

The cards used in planning poker are numbered based on variations of the Fibonacci sequence. The Fibonacci sequence is made by adding the two preceding numbers in the sequence to get the next number, such as in the sequence 1, 2, 3, 5, 8, 13, etc. It is also found in the arrangement of sunflower seeds and the way shells grow in a spiral and is considered useful for determining relative size [43].

The Development Team, on the other hand, needs to know in advance how much time they will have to carry out the work in the current Sprint. This is referred to as the team’s “capacity.” If the Product Backlog is larger than the capacity, the Product Backlog is split. If, on the other hand, the Product Backlog is smaller than the capacity, multiple Product Backlogs are selected within a single Sprint.

When determining capacity, buffers should also be considered, excluding activities other than work occurring within the Sprint (Sprint Planning, Sprint Review, Sprint Retrospective, assistance in Product Backlog grooming (the Product Owner assistance for backlog creation: writing, refining, estimating, and re-prioritizing Product Backlog items)) as well as vacations, etc. [44].

In this way, the Development Team negotiates with the Product Owner to ensure that the work to be tackled in the current Sprint is feasible from both a scheduling and technical standpoint, and ultimately make a commitment. The Sprint Backlog is the Product Backlog selected for the current Sprint complete with a list of tasks to achieve it. This Sprint Backlog will be used by the Development Team to manage daily progress during the period of the Sprint, using a task board and other tools described later [43, 44].

- Application to Digital Kaizen projects

Sprint Planning can be applied to Digital Kaizen projects in the manufacturing industry in the following manner. For example, let us assume that the User Story of Company A mentioned earlier is given as the Product Backlog: “I want to grasp the operating status of assembly machines in real time.” When the Product Owner explains the Product Backlog in terms of this User Story, the Development Team clarifies any ambiguity within the requirements through dialogue.

For example, the following points might be clarified:

- For which manufacturing equipment does the person in question want to grasp the operating status?
- How many assembly machines are subject to the requirement?
- What kind of operating status does the person in question want to grasp? (Is it just up/down time, or are there other matters they want to grasp as well?)
- Where does the person in question want to grasp the operating status? (In the factory office or on their smartphone?)
- How does the person in question want to grasp the operating status? (Do they wish to receive an alarm whenever the equipment stops, or do they simply want to be able to view the status?)

Once the requirements have been clarified, the next step is to determine how to realize them through dialogue within the Development Team. It could, for example, be handled in the following manner:

- Develop a program to capture the light signals displayed by assembly machine signal towers as image information using a Raspberry Pi.
- Develop a program that analyzes color information from the images captured by the Raspberry Pi, detects the presence or absence of abnormalities, and sends out an alert in the event of an abnormality.
- Install cameras to take pictures of the assembly machine signal towers, and the Raspberry Pi captures the signals.
- Connect another Raspberry Pi acting as a gateway to network with LoRaWAN to send alerts to smartphones via the Internet based on the acquired data.
- Configure Grafana so that the dashboard can be displayed on a PC.  
...etc.

In this manner, Sprint Planning identifies the tasks required to achieve Sprint Goal, and eventually, it breaks down the tasks into the specific daily activities.

### **Daily Scrum**

Once Sprint Planning is complete and work has begun, the Scrum Team meets at a set time each day (usually in the morning, before starting the day's work) for a short 15-minute meeting. This is called a "Daily Scrum." Because it is often done standing up, it is also sometimes referred to as the daily stand-up.

The purpose of a Daily Scrum is to allow all members of the Development Team to review the progress of the project, to share information about each other's work, and to quickly take action to remove any impediments to the progress of the work.

In the Daily Scrum, the members share with the Scrum Team what they did yesterday, what they will do today, and any impediments to the progress of their work. To share information quickly and effectively, a task board (Figure 7) and/or burndown chart (Figure 8) is created on a large sheet of paper or whiteboard. This way, the progress of the work can be seen immediately.

Also, by having all members gather in front of these tools and discussing while standing up, a lively exchange of ideas is encouraged allowing for information to be shared in a short period of time. The Daily Scrum makes it possible for the Development Team to confirm the progress of each other's work and makes it possible to adjust work procedures and help each other with any work that is lagging. Also, if any problems arise, immediate actions can be taken to resolve them [45–50].

**FIGURE 5-7**

**EXAMPLE OF A TASK BOARD**

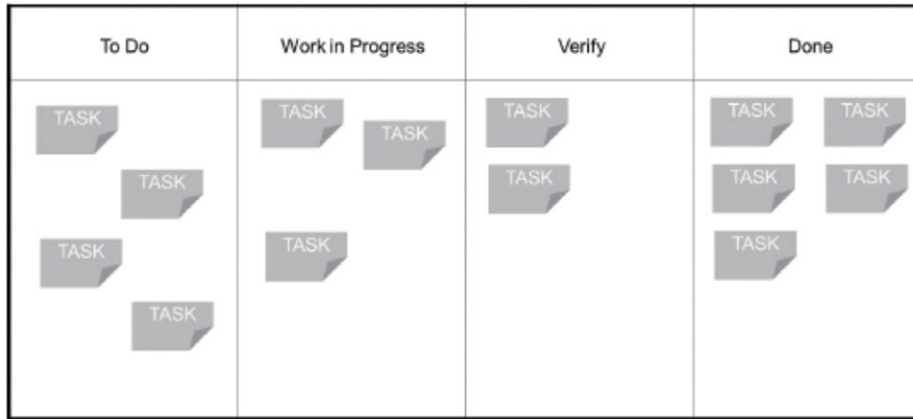

A task board can be created by writing tasks on sticky notes and pasting them onto a whiteboard, etc., and moving them in order from “To Do” to “Done” as the work progresses. This way, all members can see the progress of their tasks immediately, which facilitates spontaneous coordination and cooperation within the team [51–54].

**FIGURE 5-8**

**EXAMPLE OF A BURNDOWN CHART**

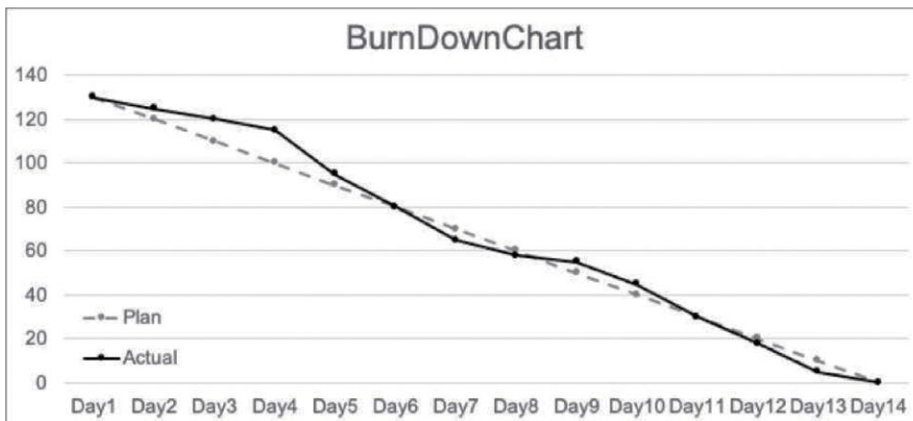

- A burndown chart is a line graph that shows time on the horizontal axis and story points (a unit of the relative size of Product Backlog items, considering complexity, physical size, etc.) on the vertical axis, and is used to show the completion status of story points as work progresses in the Sprint [55, 56].

### **Sprint Review**

Once the development of the Sprint Backlog is complete, the Sprint Review is conducted. During the Sprint Review, the Development Team demonstrates the results of the Sprint to the stakeholders. The Development Team then receives feedback on whether the direction of the development is in line with stakeholders' needs. Therefore, all members of the Scrum Team should participate, as well as all stakeholders who will be affected by the development item.

The Sprint Review allows the Scrum Team to confirm that the activities they are pursuing are aligned with the direction of development required by the stakeholders, and the stakeholders can witness the actual working product to confirm that the direction of the project is in line with their needs. This enables the Development Team to change the direction of development based on the feedback if the direction does not line up with stakeholder needs [46, 57–59].

- Application to Digital Kaizen projects

The Sprint Review can be applied to Digital Kaizen projects in the manufacturing industry in the following manner.

For example, if a project has been working on realizing the User Story of “I want to grasp the operating status of assembly machines in real time on my smartphone” as its Product Backlog, a demonstration is conducted to show how the operating status can be checked in real time on a smartphone when an assembly machine stops. Then, stakeholders are asked to confirm that the developed system meets their needs. Feedback from the stakeholders might then include a new request to be able to receive an alarm whenever a machine stops, in addition to being able to check the operating status. Such feedback will be received by the Product Owner and added to the Product Backlog.

### **Sprint Retrospective**

Once the Sprint Review is completed, the Scrum Team conducts the Sprint Retrospective. The purpose of the Sprint Retrospective is for the Scrum Team to look back on and discuss their development work process in the current Sprint, to “share their findings,” and to improve the work process for the next and subsequent Sprints based on said findings. For this reason, participation of the entire the Scrum Team is advisable. Facilitation is usually done by the Scrum Master.

During the Sprint Retrospective, the aim is to carry out open discussions about how to improve the work process, communication, deliverables, tools, and so on. To facilitate this kind of discussion, it is important for the Scrum Master to create an atmosphere in which the members can speak frankly, and to ensure psychological safety. In Scrum, it is possible to regularly assess the ongoing learning effect of the Scrum Team by practicing this kind of retrospection for each Sprint.

The following is a description of a KPT, a tool used when conducting Sprint Retrospectives. First, write down the three categories as shown in the below figure on a whiteboard or a sheet of large paper, then proceed to write down the team's thoughts on each category in the order of “Keep” (What you think went well. What you want to continue going forward), “Problem” (What did not go well), and “Try” (What you want to try next time. This can be to further improve something in the Keep category, solve something in the Problem category, or something else). Finally, everyone



agrees on the action points from the try category to be implemented in the next Sprint, and the session ends [57 and 60–63].

**FIGURE 5-9**

**KPT**

<p><b>Keep</b> Write down what went well in the current Sprint, and what you would like to continue in the next Sprint.</p>	<p><b>Try</b> Write down how to improve on the things that did not go well in the current Sprint.</p>
<p><b>Problem</b> Write down what did not go well in the current Sprint, and what you want to improve.</p>	

Then, with the end of the Sprint Retrospective, the current Sprint is completed. When one Sprint is completed, the Scrum Team immediately starts the next Sprint.

### Chapter 5.3 Deliverables at Project Completion

At the completion of each Sprint, it is advisable to record any changes in the system configuration because of development, as well as any newly introduced equipment and services, so that they can be referenced for future maintenance, operation, and system modifications. This section introduces the deliverables that should be created at the completion of a project.

#### 5.3.1 Purpose of Systemization

The developed system will normally be used for several years, and in the future, the system is likely to be modified, expanded, or replaced. After several years, it is also possible that the original members of the project team may no longer be around. In preparation for such a time, it is very important to keep records on why the project was carried out in the first place (its objective), and what type of systems were developed.

**FIGURE 5-10**

**EXAMPLE OF THE PURPOSE OF SYSTEMIZATION [64]**

Item	Content
Purpose of Systemization	To improve operating rates by making it possible to grasp the operating status of each piece of equipment on the production line in real time, and to quickly restore the system in the event of an abnormal stop or failure.
KPI (Key Performance Indicator)	To improve the operating rate of each piece of manufacturing equipment by 10% or more per month.
System Overview	Sensors are attached to each piece of manufacturing equipment, data acquired by the sensors is converted to digital data using Raspberry Pi or ESP32, and then transferred to the gateway (Raspberry Pi) using the LoRaWAN wireless method, and data from the gateway is collected via the Internet and stored in the cloud. The data collected and stored in the cloud is visualized using a dashboard tool, and an alarm notification function was developed for smartphones.

5.3.2 System Configuration Diagram

After a project is completed, it is useful to prepare a configuration diagram of the installed system for use as a reference in the case of failure during system operation, or when carrying out future system modification or expansion.

**FIGURE 5-11**  
**EXAMPLE OF A SYSTEM CONFIGURATION DIAGRAM**

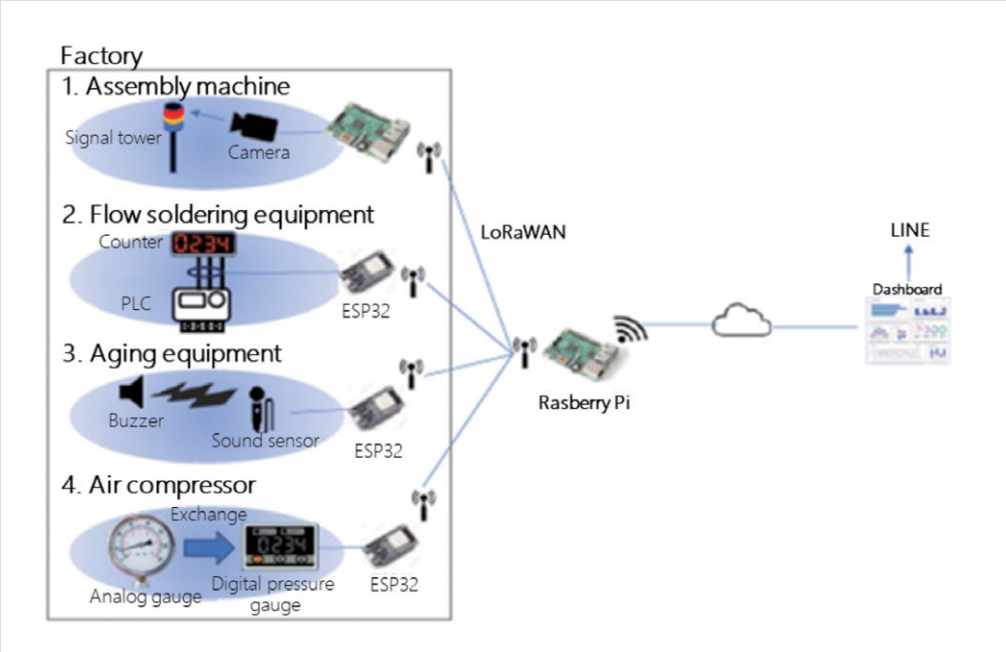

- A system configuration diagram should show immediately what equipment is connected where, how the network is connected (wireless, wired), etc.

5.3.3 List of Devices Used

It is convenient to compile a list of the devices used in the system together with their product specifications, so that it is easy to check the specifications in case of failure during system operation, or when carrying out future system modification or expansion.

In this example, the list is limited to the product name and specifications for the main items, but since PDF (Portable Document Format) files of datasheets are available for many products these days, it is also practical to store such datasheets in an electronic folder.

**FIGURE 5-12**  
**EXAMPLE OF A LIST OF DEVICES USED [65, 66]**

Product name	Item	Specifications
	<b>Processor:</b>	Broadcom BCM2711, quad-core Cortex-A72 (ARM v8) 64-bit SoC @ 1.5GHz
	<b>Memory:</b>	1GB, 2GB or 4GB LPDDR4-2400 SDRAM (depending on model)
	<b>Connectivity:</b>	2.4 GHz and 5.0 GHz IEEE 802.11b/g/n/ac wireless LAN, Bluetooth 5.0, BLE Gigabit Ethernet 2 × USB 3.0 ports, 2 × USB 2.0 ports.
	<b>GPIO:</b>	Standard 40-pin GPIO header (fully backwards-compatible with previous boards)
	<b>Video &amp; sound:</b>	2 × micro HDMI ports (up to 4Kp60 supported) 2-lane MIPI DSI display port , 2-lane MIPI CSI camera port , 4-pole stereo audio and composite video port
	<b>Multimedia:</b>	H.265 (4Kp60 decode); H.264 (1080p60 decode, 1080p30 encode); OpenGL ES, 3.0 graphics
	<b>SD card support:</b>	Micro SD card slot for loading operating system and data storage
	<b>Input power:</b>	5V DC via USB-C connector (minimum 3A1) , 5V DC via GPIO header (minimum 3A1) , Power over Ethernet (PoE)-enabled (requires separate PoE HAT)
<b>Environment:</b>	Operating temperature 0–50°C	

Product name	Category	Item	Specifications
	Hardware	Module interface	SD card, UART, SPI, SDIO, I2C, LED PWM, Motor PWM, I2S, IR
		On-chip sensor	Hall sensor, temperature sensor
		On-board clock	40 MHz crystal
		Operating voltage/Power supply	2.7 ~ 3.6V
		Operating current	Average: 80 mA
		Minimum current delivered by power supply	500 mA
		Operating temperature range	-40° C ~ +85° C
		Ambient temperature range	Normal temperature
		Package size	18 ± 0.2 mm x 25.5 ± 0.2 mm x 3.1 ± 0.15 mm
		Software	Wi-Fi mode
	Wi-Fi Security	WPA/WPA2/WPA2-Enterprise/WPS	
	Encryption	AES/RSA/ECC/SHA	
	Firmware upgrade	UART Download / OTA (download and write firmware via network or host)	
	Software development	Supports Cloud Server Development / SDK for custom firmware development	
	Network protocols	IPv4, IPv6, SSL, TCP/UDP/HTTP/FTP/MQTT	
	User configuration	AT instruction set, cloud server, Android/iOS app	

## Chapter 5.4 How to proceed when using an IT vendor

This section explains how to proceed when using an IT vendor in Digital Kaizen project, including matters to consider when selecting a vendor and important points when signing a contract.

### 5.4.1 How to Select a Vendor

The process for selecting a vendor involves a primary and secondary evaluation. In the primary evaluation, first, list as many vendors as possible (30 or more) that appear to be a good fit for your company’s planned project, such as those with experience in DX, IoT, AI, and Scrum development. Next, narrow down the list to about 10 companies based on their business size, track record, number of employees, and other information they make available to the public, and present them with a request for information (RFI).

With RFIs, each vendor is asked the same set of questions using the same format which allows for easy comparison. The questions should include company information, track record of projects similar in size and technology to the project your company is planning, number of certified IT professionals, pricing information, and so on. Following the questions, there should be a column asking the respondent to describe their “company’s strengths.” The information given in this section will provide you with an indication of the vendor’s level of commitment to the project.

Once you receive the RFI responses, the next step is to present RFPs (request for proposal) to several vendors (around five) that seem promising based on their responses. An RFP should include the background and objectives of the project, a list of issues to be resolved and functions to be realized, project duration and delivery date, as well as a proposal submission date. It is also acceptable to meet with the vendors to which RFPs are presented to explain the project.

After receiving proposals in response to the RFPs, said proposals are evaluated and the list of vendors is narrowed down to two or three finalists, which are asked to make a presentation. The final decision on which vendor to select is made after evaluating the content of their presentations [67].

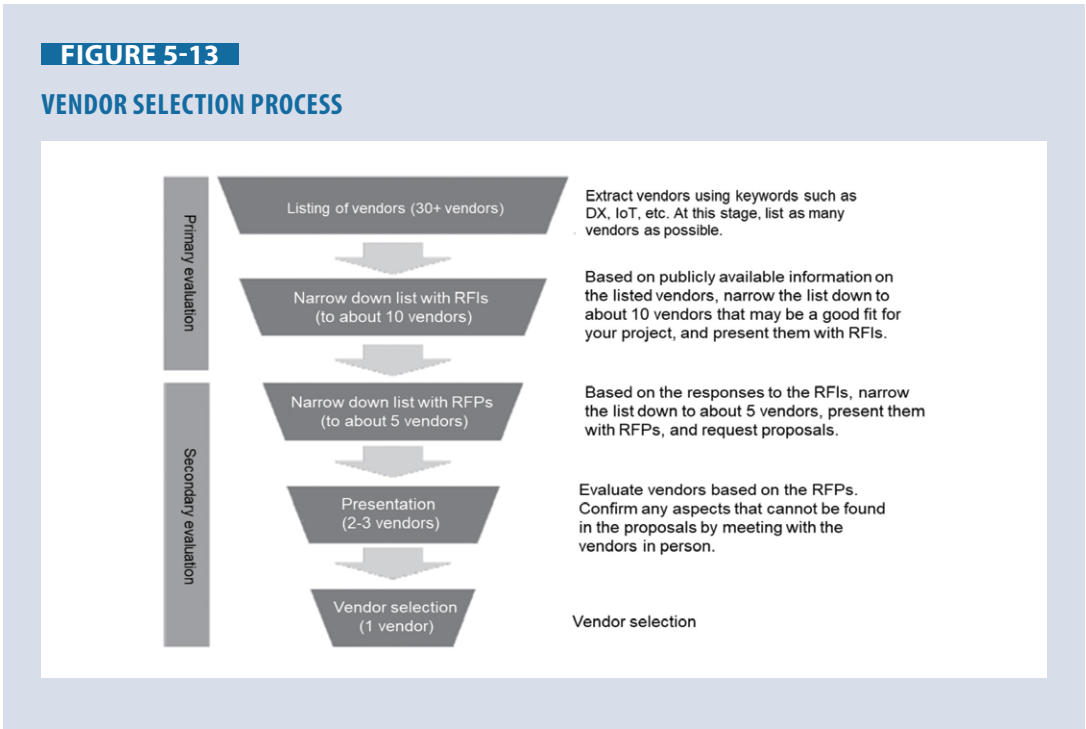

### 5.4.2 Important Points on How to Conclude a Contract

This section describes important contractual considerations when outsourcing Scrum-based system development to an IT vendor. There are three types of contracts for system development: firm fixed price, cost plus fee, and time & material contracts. The characteristics of these three contract types are as follows:

**FIGURE 5-14**  
**CONTRACT TYPES [68]**

Name	Abbreviation	Characteristics
Firm Fixed Price	FFP	A type of contract in which the amount to be paid by the ordering party to the vendor is fixed at the time the contract is concluded. In many cases, the vendor is obligated to complete and deliver all system development work covered by the contract. The contract assumes that there will be no changes to the specifications after the contract is concluded.
Cost Plus Fee	CPF	A type of contract in which the ordering party does not determine the amount to be paid to the vendor at the time the contract is concluded, and the ordering party pays all costs incurred in the implementation of the project. The total amount paid is the actual cost of the project plus the vendor's profit.
Time & Material	T&M	A type of contract in which the ordering party determines the hourly rate for the vendor at the time the contract is concluded, and pays the vendor monthly, for example, according to time spent on the project by the vendor. This type of contract is appropriate when the scope and specifications of the project are not yet determined. It has the advantage of allowing the procuring of personnel with appropriate skills and experience according to the requirements of the project.

Of these, the most suitable for Scrum is the time & material type contract. This is because a firm fixed price type contract is incompatible with the concept of Scrum, where requirements are likely to change during a project, since the contractor is obligated to create and deliver deliverables based on the scope pre-defined in the contract.

In addition, the Scrum framework requires the Product Owner, the Scrum Master, and the Development Team to work together on projects as one team. Therefore, it is important that the Scrum Team includes members from the outsourced party. As the Product Owner a member of your company should be appointed. The reason is that if the Product Owner is someone from the vendor side, it also means that the right to decide development items lies solely with the vendor. This would mean that the company's own initiative would not be demonstrated at all.

When proceeding with Scrum development, it is advisable to approach projects with the attitude that development will be conducted under the ownership of your company, and with the help of the vendor company, through co-creation by the members of both parties [69].

# REFERENCES

## Section 1 - Section 4

- [1] “Exercise of digital kaizen activities based on ‘digital triplet’ concept,” in *Procedia Manufacturing*, vol. 45, 2020, pp. 325-330.
- [2] “The role of digital technologies for the service transformation of industrial companies,” *International Journal of Production Research*, vol. 56, no. 6, pp. 2116-2132, 2018.
- [3] Ministry of Economy, Trade and Industry, “Digital Governance Code 2.0, 13 September 2022,” [https://www.meti.go.jp/policy/it\\_policy/investment/dgc/dgc2.pdf?\\_fsi=KnwIqGy6](https://www.meti.go.jp/policy/it_policy/investment/dgc/dgc2.pdf?_fsi=KnwIqGy6). Accessed on 23 February 2024.
- [4] Information Technology Promotion Agency, DX White Paper 2023, Information Technology Promotion Agency, 2023, p. 10.
- [5] Ahmed, S.F., Alam, M.S.B., Hoque, M., Lameesa, A., Afrin, S., Farah, T., Kabir, M., Shafiullah, G.M. & Muyeen, S.M. , “Industrial Internet of Things enabled technologies, challenges, and future directions,” *Computers and Electrical Engineering*, p. 110, 2023.
- [6] Chen, W., “Intelligent manufacturing production line data monitoring system for industrial internet of things,” *Computer Communications*, no. 151, pp. 31-41, 2020.
- [7] Keung, K.L., Lee, C.K.M. & Ji, P., “Industrial internet of things-driven storage location assignment and order picking in a resource synchronization and sharing-based robotic mobile fulfillment system,” *Advanced Engineering Informatics*, p. 52, 2022.
- [8] Malik, P.K., Sharma, R., Singh, R., Gehlot, A., Satapathy, S.C., Alnumay, W.S., Pelusi, D., Ghosh, U. & Nayak, J. , “Industrial Internet of Things and its Applications in Industry 4.0: State of The Art,” *Computer Communications*, no. 166, pp. 125-139, 2021.
- [9] Peter, O., Pradhan, A. & Mbohwa, C., “Industrial internet of things (IIoT): opportunities, challenges, and requirements in manufacturing businesses in emerging economies,” *Procedia Computer Science*, no. 217, pp. 856-865, 2023.
- [10] Rahman, M.S., Ghosh, T., Aurna, N.F., Kaiser, M.S., Anannya, M. & Hosen, A.S.M.S., “Machine learning and internet of things in industry 4.0: A review. Measurement: Sensors,” no. 28, 2023.
- [11] Zhang, G., Chen, C.-H., Cao, X., Zhong, R.Y., Duan, X. & Li, P., “Industrial Internet of Things-enabled monitoring and maintenance mechanism for fully mechanized mining equipment,” *Advanced Engineering Informatics*, no. 54, 2022.
- [12] Mobile Computing Promotion Consortium, IoT Technology Textbook, 3 ed., RIC TELECOM, 2021, p. 7.
- [13] Mobile Computing Promotion Consortium, IoT Technology Textbook Basics, RIC TELECOM, 2020, p. 70.
- [14] 802.11ah Promotion Council, “About 802.11ah,” <https://www.11ahpc.org/11ah/index.html>. Accessed on 24 February 2024.
- [15] Synergy Research Group, “Quarterly Cloud Market Once Again Grows by \$10 Billion from 2022; Meanwhile, Little Change at the Top | Synergy Research Group,” <https://www.srgresearch.com/articles/quarterly-cloud-market-once-again-grows-by-10-billion-from-2022-meanwhile-little-change-at-the-top>. Accessed on 24 February 2024.

- [16] IFTTT, “IFTTT - Automate business & home,” <https://ifttt.com/>. Accessed on 25 February 2024.
- [17] Zapier Inc., “Automate your work today | Zapier,” Zapier Inc.. [Online]. Accessed on 25 February 2024.
- [18] GitHub, “GitHub: Let’s build from here · GitHub,” GitHub, Inc., <https://github.com/>. Accessed on 25 February 2024.
- [19] Scratch Foundation, “Scratch - Imagine, Program, Share,” Scratch Foundation, <https://scratch.mit.edu/>. Accessed on 25 February 2024.
- [20] OpenJS Foundation, “Node-RED,” <https://nodered.org/>. Accessed on 25 February 2024.
- [21] Ministry of Economy, Trade and Industry, “AI Introduction Guidebook, 13 September 2022,” [https://www.meti.go.jp/policy/it\\_policy/jinzai/1\\_AI\\_guidebook\\_mihiraki\\_FIX.pdf](https://www.meti.go.jp/policy/it_policy/jinzai/1_AI_guidebook_mihiraki_FIX.pdf). Accessed on 25 February 2024.
- [22] Chen, Chia-Ping, and Jeff A. Bilmes, “MVA processing of speech features,” *IEEE Transactions on Audio, Speech, and Language Processing*, pp. 257-270, 2006.
- [23] Gao, Hui, “Design of Computer Software Engineering Machine Vision Platform Based on Traditional Image Algorithms,” in *2023 International Conference on Applied Intelligence and Sustainable Computing (ICAISC)*, Dharwad, India, 2023.
- [24] J. Suriya Prakash, K. Annamalai Vignesh, C. Ashok and R. Adithyan, “Multi class Support Vector Machines classifier for machine vision application,” in *2012 International Conference on Machine Vision and Image Processing (MVIP)*, Coimbatore, India, 2012.
- [25] B. V. Somasundaran, R. Soundararajan and S. Biswas, “Image Denoising for Image Retrieval by Cascading a Deep Quality Assessment Network,” in *2018 25th IEEE International Conference on Image Processing (ICIP)*, Athens, Greece, 2018.
- [26] Fan, Qingnan and Yang, Jiaolong and Wipf, David and Chen, Baoquan and Tong, Xin, “Image smoothing via unsupervised learning,” *ACM Transactions on Graphics (TOG)*, vol. 37, no. 6, 2018.
- [27] J.G.M. Schavemaker, M.J.T. Reinders, J.J. Gerbrands, E. Backer, “Image sharpening by morphological filtering,” *Pattern Recognition*, vol. 33, no. 6, pp. 997-1012, 2000.
- [28] Yiren Huang, Weidong Hao, Zhihao Wang, Hao Wu, “Engineering Applications based on Industrial Robots and Machine Vision,” in *2022 International Conference on Image Processing, Computer Vision and Machine Learning (ICICML)*, Xi’an, China, 2022.
- [29] Suárez-Varela, José and Almasan, Paul and Ferriol-Galmés, Miquel and Rusek, Krzysztof and Geyer, Fabien and Cheng, Xiang and Shi, Xiang and Xiao, Shihan and Scarselli, Franco and Cabellos-Aparicio, Albert and Barlet-Ros, Pere, “Graph Neural Networks for Communication Networks: Context, Use Cases and Opportunities,” *IEEE Network*, vol. 37, no. 3, pp. 146-153, 2023.
- [30] Alex Krizhevsky, Ilya Sutskever, Geoffrey E. Hinton, “ImageNet Classification with Deep Convolutional Neural Networks,” *Advances in neural information processing systems*, vol. 25, 2012.
- [31] Zoumana Keita, “YOLO Object Detection Explained: A Beginner’s Guide | DataCamp,” DataCamp, Inc., <https://www.datacamp.com/blog/yolo-object-detection-explained>. Accessed on 25 February 2024.
- [32] LoRa Alliance, “LoRa Alliance - Homepage - LoRa Alliance®,” <https://loro-alliance.org/>. Accessed on 25 February 2024.



- [33] OpenCV team, “OpenCV - Open Computer Vision Library,” <https://opencv.org/>. Accessed on 25 February 2024.
- [34] Raspberry Pi Foundation, “Raspberry Pi,” <https://www.raspberrypi.com/>. Accessed on 25 February 2024.
- [35] Espressif Systems, “ESP32 Wi-Fi & Bluetooth SoC | Espressif Systems,” <https://www.espressif.com/en/products/socs/esp32>. Accessed on 25 February 2024.
- [36] Bluetooth SIG, Inc., “Bluetooth Technology Overview | Bluetooth® Technology Website,” <https://www.bluetooth.com/learn-about-bluetooth/tech-overview/>. Accessed on 25 February 2024.
- [37] Wikimedia Foundation, Inc., “Low-power wide-area network - Wikipedia,” [https://en.wikipedia.org/wiki/Low-power\\_wide-area\\_network](https://en.wikipedia.org/wiki/Low-power_wide-area_network). Accessed on 25 February 2024.
- [38] Wikimedia Foundation, Inc., “Amazon Web Services - Wikipedia,” [https://en.wikipedia.org/wiki/Amazon\\_Web\\_Services](https://en.wikipedia.org/wiki/Amazon_Web_Services). Accessed on 25 February 2024.
- [39] Amazon Web Services, Inc., “What is Elasticsearch? - Elasticsearch Explained - AWS,” [https://aws.amazon.com/what-is/elasticsearch/?nc1=h\\_ls](https://aws.amazon.com/what-is/elasticsearch/?nc1=h_ls). Accessed on 25 February 2024.
- [40] Wikimedia Foundation, Inc., “Google Cloud Platform - Wikipedia,” [https://en.wikipedia.org/wiki/Google\\_Cloud\\_Platform](https://en.wikipedia.org/wiki/Google_Cloud_Platform). Accessed on 26 February 2024.
- [41] Wikimedia Foundation, Inc., “Microsoft Azure - Wikipedia,” [https://en.wikipedia.org/wiki/Microsoft\\_Azure](https://en.wikipedia.org/wiki/Microsoft_Azure). Accessed on 26 February 2024.
- [42] G. Labs, “Grafana: The open observability platform | Grafana Labs,” <https://grafana.com/>. Accessed on 26 February 2024.
- [43] Wikimedia Foundation, Inc., “Microsoft Power BI - Wikipedia,” [https://en.wikipedia.org/wiki/Microsoft\\_Power\\_BI](https://en.wikipedia.org/wiki/Microsoft_Power_BI). Accessed on 26 February 2024.
- [44] Wikimedia Foundation, Inc., “Looker Studio - Wikipedia,” [https://en.wikipedia.org/wiki/Looker\\_Studio](https://en.wikipedia.org/wiki/Looker_Studio). Accessed on 26 February 2024.
- [45] ScioSense, “Soldered\_CCS811B\_datasheet.pdf, December 2020,” [https://soldered.com/productdata/2022/03/Soldered\\_CCS811B\\_datasheet.pdf](https://soldered.com/productdata/2022/03/Soldered_CCS811B_datasheet.pdf). Accessed on 26 February 2024.
- [46] Seeed Studio, Inc., “Grove - Temp and Humi Sensor(SHT31) | Seeed Studio Wiki,” [https://wiki.seeedstudio.com/Grove-TempAndHumi\\_Sensor-SHT31/](https://wiki.seeedstudio.com/Grove-TempAndHumi_Sensor-SHT31/). Accessed on 26 February 2024.
- [47] Adafruit, “Overview | Adafruit BH1750 Ambient Light Sensor | Adafruit Learning System,” <https://learn.adafruit.com/adafruit-bh1750-ambient-light-sensor/overview>. Accessed on 26 February 2024.
- [48] STMicroelectronics, “LPS25H - MEMS pressure sensor: 260-1260 hPa absolute digital output barometer - STMicroelectronics,” <https://www.st.com/en/mems-and-sensors/lps25h.html>. Accessed on 26 February 2024.
- [49] Amazon Web Services, Inc., “What is AWS IoT? - AWS IoT Core,” <https://docs.aws.amazon.com/iot/latest/developerguide/what-is-aws-iot.html>. Accessed on 26 February 2024.
- [50] Amazon Web Services, Inc., “Fast NoSQL Key-Value Database – Amazon DynamoDB – Amazon Web Services,” <https://aws.amazon.com/dynamodb/>. Accessed on 26 February 2024.
- [51] Amazon Web Services, Inc., “Push Notification Service - Amazon Simple Notification Service - AWS,” <https://aws.amazon.com/sns/>. Accessed on 26 February 2024.
- [52] Wikimedia Foundation, Inc., “Kibana - Wikipedia,” <https://en.wikipedia.org/wiki/Kibana>. Accessed on 26 February 2024.

- [53] “Industrial aspects and literature survey: Combined inventory management and routing,” *Computers & Operations Research*, vol. 37, no. 9, pp. 1515-1536, 9 2010.
- [54] Brent D. Williams, Travis Tokar., “A review of inventory management research in major logistics journals: Themes and future directions,” *The International Journal of Logistics Management*, 15 8 2008.
- [55] Weinstein, Ron, “RFID: a technical overview and its application to the enterprise,” *IT professional*, vol. 7, no. 3, pp. 27-33, 2005.
- [56] Juels, Ari, “RFID security and privacy: a research survey,” *IEEE journal on selected areas in communications*, vol. 24, no. 2, pp. 381-394, 2006.
- [57] Wikimedia Foundation, Inc., “Radio-frequency identification - Wikipedia,” [https://en.wikipedia.org/wiki/Radio-frequency\\_identification](https://en.wikipedia.org/wiki/Radio-frequency_identification). Accessed on 26 February 2024.
- [58] *International Journal of Production Economics*, vol. 112, no. 2, pp. 510-520, 4 2008.
- [59] Curtin, John and Kauffman, Robert J and Riggins, Frederick J, “Making the ‘MOST’ out of RFID technology: a research agenda for the study of the adoption, usage and impact of RFID,” *Information Technology and Management*, vol. 8, p. 87–110, 2007.
- [60] Ni, Lionel M and Zhang, Dian and Souryal, Michael R, “RFID-based localization and tracking technologies,” *IEEE Wireless Communications*, vol. 18, no. 2, pp. 45-51, 2011.
- [61] Kumar, P and Reinitz, HW and Simunovic, J and Sandeep, KP and Franzon, PD, “Overview of RFID technology and its applications in the food industry,” *Journal of food science*, vol. 74, no. 8, pp. R101--R106, 2009.
- [62] Wyld, David C., “RFID 101: the next big thing for management,” *Management Research News*, vol. 29, no. 4, pp. 154-173, 2006.
- [63] Wikimedia Foundation, Inc., “Variable-frequency drive - Wikipedia,” [https://en.wikipedia.org/wiki/Variable-frequency\\_drive](https://en.wikipedia.org/wiki/Variable-frequency_drive). Accessed on 26 February 2024.
- [64] Polycase, “What Is a Programmable Logic Controller (PLC)? | Polycase | Polycase,” <https://www.polycase.com/techtalk/electronics-tips/what-is-a-programmable-logic-controller.html>. Accessed on 26 February 2024.
- [65] X. a. T. V. Chen, “Implementation of the Manufacturing Execution System in the food and beverage industry,” *Journal of Food Engineering*, vol. 278, p. 109932, 2020.
- [66] D’Antonio, Gianluca, Joel Sauza Bedolla, and Paolo Chiabert, “A novel methodology to integrate manufacturing execution systems with the lean manufacturing approach,” *Procedia Manufacturing*, vol. 11, pp. 2243-2251, 2017.
- [67] Jaskó, S., Skrop, A., Holczinger, T., Chován, T. & Abonyi, J., “Development of manufacturing execution systems in accordance with Industry 4.0 requirements: A review of standard- and ontology-based methodologies and tools,” *Computers in Industry*, vol. 11, pp. 2243-2251, 2020.
- [68] Mantravadi, Soujanya, and Charles Møller, “An overview of next-generation manufacturing execution systems: How important is MES for industry 4.0?,” *Procedia manufacturing*, vol. 30, pp. 588-595, 2019.
- [69] Menezes, Sherwin, Savio Creado, and Ray Y. Zhong, “Smart manufacturing execution systems for small and medium-sized enterprises,” *Procedia CIRP*, vol. 72, pp. 1009-1014, 2018.
- [70] Wikimedia Foundation, Inc., “Raspberry Pi - Wikipedia,” [https://en.wikipedia.org/wiki/Raspberry\\_Pi](https://en.wikipedia.org/wiki/Raspberry_Pi). Accessed on 26 February 2024.

- [71] Raspberry Pi Foundation, “GPIO pins | Physical Computing with Python | Python | Coding projects for kids and teens,” <https://projects.raspberrypi.org/en/projects/physical-computing/1>. Accessed on 26 February 2024.
- [72] RealVNC® Limited, “Download VNC Viewer | VNC® Connect,” <https://www.realvnc.com/en/connect/download/viewer/>. Accessed on 26 February 2024.
- [73] Microsoft, “Visual Studio Code - Code Editing. Redefined,” <https://code.visualstudio.com/>. Accessed on 26 February 2024.
- [74] SENSATEC Co., Ltd, “形MDS-F4-5V 小形近接センサ | 近接センサ | 産機用 | 製品情報 | センサテック株式会社 センサの企画・開発・OEM,” [https://www.sensatec.co.jp/products/detail.php?product\\_id=363](https://www.sensatec.co.jp/products/detail.php?product_id=363). Accessed on 26 February 2024.
- [75] Bosch Sensortec GmbH, “Humidity Sensor BME280 | Bosch Sensortec,” <https://www.bosch-sensortec.com/products/environmental-sensors/humidity-sensors-bme280/>. Accessed on 26 February 2024.
- [76] Analog Devices, Inc., “I2 C Primer: What is I2C? (Part 1) | Analog Devices,” <https://www.analog.com/en/resources/technical-articles/i2c-primer-what-is-i2c-part-1.html>. Accessed on 26 February 2024.
- [77] MathWorks, Inc., “IoT Analytics - ThingSpeak Internet of Things,” <https://thingspeak.com/>. Accessed on 27 February 2024.
- [78] MathWorks, Inc., “Channels - ThingSpeak IoT,” <https://thingspeak.com/channels/new>. Accessed on 27 February 2024.
- [79] MathWorks, Inc., “API Keys - ThingSpeak IoT,” [https://thingspeak.com/channels/\(number\)/api\\_keys](https://thingspeak.com/channels/(number)/api_keys). Accessed on 27 February 2024.
- [80] MathWorks, Inc., “(project name) - ThingSpeak IoT,” [https://thingspeak.com/channels/\(number\)/private\\_show](https://thingspeak.com/channels/(number)/private_show). Accessed on 27 February 2024.
- [81] The contents of the Development of IoT System for Productivity Improvement using PLC and Low-cost Embedded Computer (not for sale) were used as a reference when creating the structure of this chapter.
- [82] InfluxData Inc. InfluxDB Cloud database service information. <https://www.influxdata.com/>, Accessed on 22 November 2023.
- [83] Grafana Labs. Grafana Cloud SaaS observability platform information. <https://grafana.com/>, Accessed on 22 November 2023.
- [84] Wikimedia Foundation, Inc., “Pulse-width modulation - Wikipedia,” [https://en.wikipedia.org/wiki/Pulse-width\\_modulation](https://en.wikipedia.org/wiki/Pulse-width_modulation). Accessed on 27 February 2024.
- [85] Texas Instruments, Incorporated., “INA219 data sheet, product information and support | TI.com,” <https://www.ti.com/product/INA219>. Accessed on 27 February 2024.

## Section 5

- [1] Kenji Hiranabe, Ikujiro Nonaka, and Takao Oyobe. Agile and Scrum; Shoeisha Co., Ltd.; 2022;29-31.
- [2] Kenneth S. Rubin, translated by Yuji Okazawa, Masanori Kado, Masahiro Takagi, Yukei Wachi. Essential Scrum. Shoeisha Co., Ltd.; 2022; 29-43.
- [3] Hiromi Nakatani. Agile Project Management; JMA Management Center Inc.;2022.; 46-51.

- [4] Digital.ai Software Inc. 15th State of Agile Report (2021). <https://info.digital.ai/rs/981-LQX-968/images/SOA15.pdf>. accessed on 18 February 2024.
- [5] Kenji Hiranabe, Ikujiro Nonaka, and Takao Oyobe. Agile and Scrum; Shoeisha Co., Ltd.; 2022;42.
- [6] Jeff Sutherland, translated by Noriko Ishigaki. SCRUM The Art of Doing Twice the Work in Half the Time; Hayakawa Publishing Corporation; 2015; 50-52.
- [7] Hirotaka Takeuchi and Ikujiro Nonaka. 'The New Product Development Game' in the January 1986 issue of Harvard Business Review; Harvard Business Publishing; January 1986.
- [8] Jeff Sutherland, translated by Noriko Ishigaki. SCRUM The Art of Doing Twice the Work in Half the Time; Hayakawa Publishing Corporation; 2015; 26-27, 112-113, 122-137.
- [9] Ken Schwaber & Jeff Sutherland. Scrum Guide., 2020 edition; <https://scrumguides.org/docs/scrumguide/v2020/2020-Scrum-Guide-Japanese.pdf>. accessed on 18 February 2024; 4.
- [10] Jeff Sutherland, translated by Noriko Ishigaki. SCRUM The Art of Doing Twice the Work in Half the Time; Hayakawa Publishing Corporation; 2015; 65.
- [11] Ken Schwaber & Jeff Sutherland. Scrum Guide., 2020 edition; <https://scrumguides.org/docs/scrumguide/v2020/2020-Scrum-Guide-Japanese.pdf>. accessed on 18 February 2024; 5.
- [12] Toshihiro Ichitani and Takeshi Arai. Kaizen Journey - from just one person to creating 'cross-border' teams. Shoeisha Co., Ltd.; 2018; 67.
- [13] Ken Schwaber & Jeff Sutherland. Scrum Guide., 2020 edition; <https://scrumguides.org/docs/scrumguide/v2020/2020-Scrum-Guide-Japanese.pdf>. accessed on 18 February 2024; 6-8.
- [14] Jeff Sutherland, translated by Noriko Ishigaki. SCRUM The Art of Doing Twice the Work in Half the Time; Hayakawa Publishing Corporation; 2015; 81-91, 226-259, 298-299.
- [15] Kenneth S. Rubin, translated by Yuji Okazawa, Masanori Kado, Masahiro Takagi, Yukei Wachi. Essential Scrum. Shoeisha Co., Ltd.; 2022; 14-17, 160-201.
- [16] Kenji Hiranabe, Ikujiro Nonaka, and Takao Oyobe. Agile and Scrum; Shoeisha Co., Ltd.; 2022;52-56.
- [17] Hiromi Nakatani. Agile Project Management; JMA Management Center Inc.;2022; 143-145.
- [18] Toshihiro Ichitani and Takeshi Arai. Kaizen Journey - from just one person to creating 'cross-border' teams. Shoeisha Co., Ltd. 2018; 145.
- [19] Ken Schwaber & Jeff Sutherland. Scrum Guide., 2020 edition; <https://scrumguides.org/docs/scrumguide/v2020/2020-Scrum-Guide-Japanese.pdf>. accessed on 18 February 2024. 12.
- [20] Jeff Sutherland, translated by Noriko Ishigaki. SCRUM The Art of Doing Twice the Work in Half the Time; Hayakawa Publishing Corporation; 2015; 221-259.
- [21] Kenneth S. Rubin, translated by Yuji Okazawa, Masanori Kado, Masahiro Takagi, Yukei Wachi. Essential Scrum. Shoeisha Co., Ltd.; 2022; 17-28, 96-114.
- [22] Kenji Hiranabe, Ikujiro Nonaka, and Takao Oyobe. Agile and Scrum; Shoeisha Co., Ltd.; 2022; 59-60.
- [23] Hiromi Nakatani. Agile Project Management; JMA Management Center Inc.;2022; 150-153.
- [24] Jeff Sutherland, translated by Noriko Ishigaki. SCRUM The Art of Doing Twice the Work in Half the Time; Hayakawa Publishing Corporation; 2015; 173-179.

- [25] Kenneth S. Rubin, translated by Yuji Okazawa, Masanori Kado, Masahiro Takagi, Yukei Wachi. Essential Scrum. Shoeisha Co., Ltd.; 2022; 76-95.
- [26] Kenji Hiranabe, Ikujiro Nonaka, and Takao Oyobe. Agile and Scrum; Shoeisha Co., Ltd.; 2022;72-73.
- [27] Toshihiro Ichitani and Takeshi Arai. Kaizen Journey - from just one person to creating ‘cross-border’ teams. Shoeisha Co., Ltd. 2018; 208-215.
- [28] Ken Schwaber & Jeff Sutherland. Scrum Guide., 2020 edition; <https://scrumguides.org/docs/scrumguide/v2020/2020-Scrum-Guide-Japanese.pdf>. accessed on 18 February 2024; 8-9.
- [29] Jeff Sutherland, translated by Noriko Ishigaki. SCRUM The Art of Doing Twice the Work in Half the Time; Hayakawa Publishing Corporation; 2015; 94-109.
- [30] Kenneth S. Rubin, translated by Yuji Okazawa, Masanori Kado, Masahiro Takagi, Yukei Wachi. Essential Scrum. Shoeisha Co., Ltd.; 2022; 21, 58-74, 315-368.
- [31] Kenji Hiranabe, Ikujiro Nonaka, and Takao Oyobe. Agile and Scrum; Shoeisha Co., Ltd.; 2022; 57-63.
- [32] Hiromi Nakatani. Agile Project Management; JMA Management Center Inc.;2022; 145-150.
- [33] Ken Schwaber & Jeff Sutherland. Scrum Guide., 2020 edition; <https://scrumguides.org/docs/scrumguide/v2020/2020-Scrum-Guide-Japanese.pdf>. accessed on 18 February 2024; 9-10.
- [34] Jeff Sutherland, translated by Noriko Ishigaki. SCRUM The Art of Doing Twice the Work in Half the Time; Hayakawa Publishing Corporation; 2015; 143-187.
- [35] Kenneth S. Rubin, translated by Yuji Okazawa, Masanori Kado, Masahiro Takagi, Yukei Wachi. Essential Scrum. Shoeisha Co., Ltd.; 2022; 22, 249-250, 316-326, 329.
- [36] Kenji Hiranabe, Ikujiro Nonaka, and Takao Oyobe. Agile and Scrum; Shoeisha Co., Ltd.; 2022;57-58.
- [37] Hiromi Nakatani. Agile Project Management; JMA Management Center Inc.;2022; 147.
- [38] Toshihiro Ichitani and Takeshi Arai. Kaizen Journey - from just one person to creating ‘cross-border’ teams. Shoeisha Co., Ltd. 2018; 73-75.
- [39] Jeff Sutherland, translated by Noriko Ishigaki. SCRUM The Art of Doing Twice the Work in Half the Time; Hayakawa Publishing Corporation; 2015; 156-170.
- [40] Kenneth S. Rubin, translated by Yuji Okazawa, Masanori Kado, Masahiro Takagi, Yukei Wachi. Essential Scrum. Shoeisha Co., Ltd.; 2022; 125-128.
- [41] Kenji Hiranabe, Ikujiro Nonaka, and Takao Oyobe. Agile and Scrum; Shoeisha Co., Ltd.; 2022; 73-74.
- [42] Toshihiro Ichitani and Takeshi Arai. Kaizen Journey - from just one person to creating ‘cross-border’ teams. Shoeisha Co., Ltd. 2018; 182-184.
- [43] Jeff Sutherland, translated by Noriko Ishigaki. SCRUM The Art of Doing Twice the Work in Half the Time; Hayakawa Publishing Corporation; 2015; 159.
- [44] Kenneth S. Rubin, translated by Yuji Okazawa, Masanori Kado, Masahiro Takagi, Yukei Wachi. Essential Scrum. Shoeisha Co., Ltd.; 2022; 321-323.
- [45] Ken Schwaber & Jeff Sutherland. Scrum Guide., 2020 edition; <https://scrumguides.org/docs/scrumguide/v2020/2020-Scrum-Guide-Japanese.pdf>. Accessed on 18 February 2024; 10.

- [46] Jeff Sutherland, translated by Noriko Ishigaki. SCRUM The Art of Doing Twice the Work in Half the Time; Hayakawa Publishing Corporation; 2015; 94-109, 302-303.
- [47] Kenneth S. Rubin, translated by Yuji Okazawa, Masanori Kado, Masahiro Takagi, Yukei Wachi. Essential Scrum. Shoeisha Co., Ltd.; 2022; 24-25, 334.
- [48] Kenji Hiranabe, Ikujiro Nonaka, and Takao Oyobe. Agile and Scrum; Shoeisha Co., Ltd.; 2022;74-76.
- [49] Hiromi Nakatani. Agile Project Management; JMA Management Center Inc.;2022; 147-148.
- [50] Toshihiro Ichitani and Takeshi Arai. Kaizen Journey - from just one person to creating ‘cross-border’ teams. Shoeisha Co., Ltd. 2018; 66.
- [51] Jeff Sutherland, translated by Noriko Ishigaki. SCRUM The Art of Doing Twice the Work in Half the Time; Hayakawa Publishing Corporation; 2015; 199-204.
- [52] Kenneth S. Rubin, translated by Yuji Okazawa, Masanori Kado, Masahiro Takagi, Yukei Wachi. Essential Scrum. Shoeisha Co., Ltd.; 2022; 335-336.
- [53] Kenji Hiranabe, Ikujiro Nonaka, and Takao Oyobe. Agile and Scrum; Shoeisha Co., Ltd.; 2022;78-80.
- [54] Hiromi Nakatani. Agile Project Management; JMA Management Center Inc.;2022; 54.
- [55] Kenneth S. Rubin, translated by Yuji Okazawa, Masanori Kado, Masahiro Takagi, Yukei Wachi. Essential Scrum. Shoeisha Co., Ltd.; 2022; 336-337.
- [56] Kenji Hiranabe, Ikujiro Nonaka, and Takao Oyobe. Agile and Scrum; Shoeisha Co., Ltd.; 2022;80-83.
- [57] Ken Schwaber & Jeff Sutherland. Scrum Guide., 2020 edition; <https://scrumguides.org/docs/scrumguide/v2020/2020-Scrum-Guide-Japanese.pdf>. accessed on 18 February 2024; 10-11.
- [58] Kenneth S. Rubin, translated by Yuji Okazawa, Masanori Kado, Masahiro Takagi, Yukei Wachi. Essential Scrum. Shoeisha Co., Ltd.; 2022; 26-27, 341.
- [59] Kenji Hiranabe, Ikujiro Nonaka, and Takao Oyobe. Agile and Scrum; Shoeisha Co., Ltd.; 2022; 58-59.
- [60] Jeff Sutherland, translated by Noriko Ishigaki. SCRUM The Art of Doing Twice the Work in Half the Time; Hayakawa Publishing Corporation; 2015; 194-220, 303-304.
- [61] Kenneth S. Rubin, translated by Yuji Okazawa, Masanori Kado, Masahiro Takagi, Yukei Wachi. Essential Scrum. Shoeisha Co., Ltd.; 2022; 27-28, 351-368.
- [62] Kenji Hiranabe, Ikujiro Nonaka, and Takao Oyobe. Agile and Scrum; Shoeisha Co., Ltd.; 2022;59, 76-78.
- [63] Toshihiro Ichitani and Takeshi Arai. Kaizen Journey - from just one person to creating ‘cross-border’ teams. Shoeisha Co., Ltd. 2018; 21-28.
- [64] Yasuhiro Nishimura. Understanding IoT System Projects - from Planning and Development to Operation and Maintenance, Shoeisha Co., Ltd.; 2020; Chapter 6.7.
- [65] raspberry-pi-4-product-brief.pdf; <https://datasheets.raspberrypi.com/rpi4/raspberry-pi-4-product-brief.pdf>; accessed on 18 February 2024; 3.
- [66] esp32-wroom-32\_datasheet\_en.pdf; [https://www.espressif.com/sites/default/files/documentation/esp32-wroom-32\\_datasheet\\_en.pdf](https://www.espressif.com/sites/default/files/documentation/esp32-wroom-32_datasheet_en.pdf); accessed on 18 February 2024; 6-7.

- [67] Shohei Tamura. Why do System Orders by Your Company Fail in ‘Vendor Selection’? Gijutsu-Hyohron Co., Ltd.; 2022; 101.
- [68] Kazuya Maeda. Illustrated textbook for quick and easy understanding of the knowledge and methods of PMBOK 6th edition in a single volume. Gijutsu-Hyohron Co., Ltd.; 2020; 140-141.
- [69] Kenji Hiranabe, Ikujiro Nonaka, and Takao Oyobe. Agile and Scrum; Shoeisha Co., Ltd.; 2022;103.



# APPENDIX

## 1. Glossary

### A

<b>Agile development</b>	Agile development is iterative and incremental development that can deliver software agilely and quickly. By delivering working, useful software in each iteration, the development side and the business side can communicate through “real software”. Agile development not only keeps up with changing requirements, but also brings about new changes.
<b>AI</b>	Artificial Intelligence (AI) is the simulation of human intelligence processes by machines, especially computer systems.
<b>API</b>	API stands for Application Programming Interface. It is a set of rules and protocols that allows software applications to communicate and share information with each other. APIs enable developers to easily integrate different services and functionalities into their own applications.
<b>Application</b>	Application is a computer software designed to help you perform a specific task.
<b>Arduino</b>	Arduino is an open-source hardware and software company, project, and user community that designs and manufactures single-board microcontrollers and microcontroller kits for building digital devices.
<b>Autonomation (Jidoka)</b>	Autonomation (known as Jidoka in Toyota Production System) is addition of an element of human intelligence to automated machinery. It is a quality control process that applies the following four principles: 1) detect the abnormality, 2) stop, 3) fix or correct the immediate condition, 4) investigate the root cause and install a countermeasure.
<b>Autocomplete</b>	Autocomplete works so that when the writer writes the first letter or letters of a word, the program predicts one or more possible words (also function names) as choices. If the intended word is included in the list, the writer can select it, for example, by using the number keys.
<b>AWS</b>	AWS, or Amazon Web Services, is a comprehensive and widely adopted cloud platform offered by Amazon. It provides a mix of infrastructure as a service (IaaS), platform as a service (PaaS), and packaged software as a service (SaaS) offering. AWS services can offer organization tools such as computing power, database storage, and content delivery services.
<b>Azure (Microsoft)</b>	Azure is a cloud computing platform run by Microsoft, which offers access, management, and development of applications and services through global data centers.

### B

<b>Big Data</b>	Big Data refers to extremely large data sets that may be analyzed computationally to reveal patterns, trends, and associations, especially relating to human behavior and interactions.
-----------------	---

<b>Blockchain</b>	A system in which a record of transactions, especially those made in a cryptocurrency, is maintained across computers that are linked in a peer-to-peer network.
<b>BLE</b>	Bluetooth Low Energy (BLE) is a wireless, low-power personal area network that operates in the 2.4 GHz ISM band.
<b>BME280</b>	BME280 is a humidity, pressure and temperature sensor developed specifically for mobile applications where size and low power consumption are key requirements.
<b>BMP280</b>	BMP280 is a barometric and air temperature sensor; the difference with BME280 is that it cannot measure humidity.

## C

<b>Cloud</b>	Cloud refers to servers that are accessed over the Internet, and the software and databases that run on those servers.
<b>Cron</b>	Cron, in UNIX-based operating systems, is a software utility that allows tasks to be executed automatically at scheduled times
<b>Cross-platform</b>	Cross-platform is a program that can run the same application on different platforms such as iOS, Android, Windows, macOS, etc.
<b>Crontab</b>	Crontab, which is short for cron table, is a file containing the schedule of various cron entries that should be run at specified times.
<b>CSV</b>	Comma-separated values (CSV) is a text file format that uses commas to separate values.

## D

<b>DaaS</b>	Data as a Service (DaaS) is an information provision and distribution model in which data files (including text, images, sounds, and videos) are made available to customers over a network, typically the Internet.
<b>Digital Kaizen</b>	Kaizen focuses on eliminating production inefficiency, error-proofing processes, and engaging production staff. Digital Kaizen focuses on improving the manufacturing setup by changing workflows and examining process steps throughout the value stream using new digital tools.
<b>Digital Optimization</b>	Digital Optimization is about using technology to do what you already do while Digital Transformation (DX) is the process of using technology to change and improve your business model itself.
<b>DX (Digital Transformation)</b>	DX (Digital Transformation) is the process by which a company, responding to the rapid changes in its business environment, based on the needs of customers and society, transforms its products, services, and business models, as well as its operations, organization, business processes, corporate culture, and tradition, using data and digital technology, thereby eventually establishes a competitive advantage. (defined by the Ministry of Economy, Trade and Industry of Japan)
<b>Digital Twin</b>	Digital Twin is a dynamic virtual copy of a physical asset, process, system or environment that looks like and behaves identically to its real-world counterpart.

## E

<b>Elasticsearch</b>	Elasticsearch is a distributed, free and open search and analytics engine for all types of data, including textual, numerical, geospatial, structured, and unstructured, which is built on Apache Lucene.
----------------------	---

<b>ERP</b>	Enterprise Resource Planning (ERP) is a platform companies use to manage and integrate the essential parts of their businesses.
<b>ESP32</b>	ESP32 is a series of low-cost, low-power system on a chip microcontroller with integrated Wi-Fi and dual-mode Bluetooth.

## G

<b>Gateway</b>	Gateway is a network node used in telecommunications that connects two networks with different transmission protocols together. The gateway collects data from sensors and smartphones, which are also known as edge devices, and sends it to the internet via the network. The gateway also manages and controls edge devices, allowing remote management and monitoring of the sensors' status.
<b>GND</b>	Ground (GND) is a circuit that determines the standard for electrical potential and is necessary for the smooth flow of electricity.
<b>Git</b>	Git is a free and open source distributed version control system designed to handle everything from small to very large projects with speed and efficiency.
<b>GitHub</b>	GitHub is a platform and cloud-based service for software development and version control using Git, allowing developers to store and manage their code.
<b>Google Drive</b>	Google Drive is a free cloud-based storage service that enables users to store and access files online. <a href="https://workspace.google.com/products/drive/">https://workspace.google.com/products/drive/</a>
<b>Grafana</b>	Grafana is a multi-platform open source analytics and interactive visualization web application. It provides charts, graphs, and alerts for the web when connected to supported data sources.
<b>Grove-Loudness Sensor</b>	Grove-Loudness Sensor is designed to detect the sound of environment based on LM2904 amplifier and a built-in microphone.
<b>GUI</b>	Graphical User Interface (GUI) is an interface through which a user interacts with electronic devices such as computers and smartphones using icons, menus and other visual indicators or representations.

## H

<b>HDMI</b>	High-Definition Multimedia Interface (HDMI) is a proprietary audio/video interface for transmitting uncompressed video data and compressed or uncompressed digital audio data from an HDMI-compliant source device, such as a display controller, to a compatible computer monitor, video projector, digital television, or digital audio device.
-------------	---

## I

<b>ICT</b>	Abbreviation for Information and Communications Technology.
<b>IDE</b>	Integrated Development Environment (IDE) is a software application that provides comprehensive facilities for software development such as Python IDE, etc.
<b>IFTTT</b>	IFTTT stands for "If This Then That." It's a free web service that helps users automate web-based tasks and improve productivity. IFTTT connects various developers' devices, services, and apps to create "applets" that perform automations.
<b>Industry 4.0</b>	Industry 4.0 refers to the intelligent networking of machines and processes for industry with the help of information and communication technology.

<b>InfluxDB</b>	InfluxDB is an open-source time series database (TSDB) developed by the company InfluxData, which is designed to handle high-speed and high-volume data ingest and real-time data analysis.
<b>IoT</b>	Internet of Things (IoT) describes the network of physical objects- “things”-that are embedded with sensors, software, and other technologies for the purpose of connecting and exchanging data with other devices and systems over the internet.
<b>iPaaS</b>	iPaaS (Integration-Platform-as-a-Service) is a self-service cloud-based solution that standardizes how applications are integrated.
<b>I2C</b>	Inter-Integrated Circuit (I2C), multi-master/multi-slave (controller/target), packet switched, single-ended, serial communication bus.

## J

<b>Just-In-Time (JIT)</b>	Just-In-Time (JIT) inventory system is a management strategy that aligns raw-material orders from suppliers directly with production schedules.
<b>JSON</b>	JavaScript Object Notation (JSON) is a lightweight data-interchange format. It is a common data format with diverse uses in electronic data interchange, including that of web applications with servers.

## K

<b>Kaizen</b>	Kaizen is a concept referring to business activities that continuously improve all functions and involve all employees from the CEO to the assembly line workers.
<b>Kanban</b>	Kanban (meaning signboard or billboard) is a scheduling system for lean manufacturing (also called just-in-time manufacturing, abbreviated JIT) developed to improve manufacturing efficiency.
<b>Kibana</b>	Kibana is a source-available data visualization dashboard software for Elasticsearch.
<b>KPI</b>	KPI stands for Key Performance Indicator, a quantifiable measure of performance over time for a specific objective.
<b>KPT</b>	KPT method (Keep Problem Try) is a team retrospective formalization method. It can be used combined with any other agile methodology and is inspired by the Kaizen principle originally created by Toyota.

## L

<b>Linux</b>	Linux is a Unix-like, open source and community-developed operating system (OS) for computers, servers, mainframes, mobile devices, and embedded devices.
<b>LoRaWAN</b>	Long Range Wide Area Network (LoRaWAN) is a networking protocol designed to wirelessly connect battery operated devices to the internet in regional, national, or global networks, and targets key Internet of things (IoT) requirements such as bi-directional communication, end-to-end security, mobility and localization services.
<b>LPWA</b>	Low-Power Wide-Area (LPWA) serves as a generic term for any network designed to communicate wirelessly with lower power than other networks such as cellular, satellite, or Wi-Fi.

M	
<b>MES</b>	Manufacturing Execution System (MES) is computerized system used in manufacturing to track and document the transformation of raw materials to finished goods.
<b>Muda</b>	Muda is a Japanese word meaning “futility”, “uselessness”, or “wastefulness”, and is a key concept in lean process thinking such as in the Toyota Production System (TPS), denoting one of three types of deviation from optimal allocation of resources.
N	
<b>Node-RED</b>	Node-RED is a flow-based, low-code development tool for visual programming developed originally by IBM for wiring together hardware devices, APIs and online services as part of IoT.
O	
<b>OCR</b>	Optical Character Recognition (OCR) is referred to as text recognition. An OCR program extracts and repurposes data from scanned documents, camera images and image-only pdfs.
<b>OpenCV</b>	Open Source Computer Vision Library (OpenCV) is a library of programming functions mainly for real-time computer vision, originally developed by Intel.
<b>Optimization</b>	Optimization is an act, process, or methodology of making something (such as a design, system, or decision) as fully perfect, functional, or effective as possible
P	
<b>P2M</b>	P2M means the unique body of knowledge framework of “project and program management for enterprise innovation”.
<b>Piezoelectric sensor</b>	Piezoelectric sensor is a device that uses the piezoelectric effect to measure changes in pressure, acceleration, temperature, strain, or force by converting them to an electrical charge.
<b>Pip/Pip3</b>	Pip is one of the package management systems for managing packages developed in the Python programming language. Pip3 is a version of the pip installer for python3, which can download and configure new python modules with a single command.
<b>Planning Poker</b>	Planning poker, also called Scrum poker, is a consensus-based, gamified technique for estimating, mostly used for timeboxing in Agile principles.
<b>PLC</b>	Programmable Logic Controller (PLC) or Programmable Controller is an industrial computer that has been ruggedized and adapted for the control of manufacturing processes.
<b>PoC</b>	Proof of Concept (PoC) is a demonstration of a product in which work is focused on determining whether an idea can be turned into a reality.
<b>PMBOK</b>	Project Management Body of Knowledge (PMBOK) is a standard set of processes, guidelines, and best practices used in project management
<b>Predictive Maintenance</b>	Predictive maintenance refers to the use of data-driven, proactive maintenance methods that are designed to analyze the condition of equipment and help predict when maintenance should be performed.

<b>Product Backlog</b>	Product Backlog is a prioritized list of work for the development team that emerges from the roadmap and its requirements.
<b>Project Management</b>	Project Management is the application of processes, methods, skills, knowledge and experience to achieve specific project objectives according to the project acceptance criteria within agreed parameters.
<b>Python</b>	Python is a computer programming language often used to build websites and software, automate tasks, and conduct data analysis.
<b>Python Libraries</b>	Python libraries are collections of reusable code modules that you can integrate into your projects to save time and effort. They are like a toolbox, each providing different tools that can be used to perform various tasks efficiently.

## Q

<b>QC</b>	Quality Control (QC) is a process by which entities review the quality of all factors involved in production.
<b>QC 7 tools / 7 QC tools</b>	The 7 QC basic tools are: 1) Check sheet, 2) Fishbone diagram (cause and effect diagram, or Ishikawa diagram), 3) Histogram, 4) Pareto chart, 5) Control chart, 6) Scatter diagram, 7) Stratification.

## R

<b>Raspberry PI (RPI)</b>	Raspberry Pi is a low cost, credit-card sized computer that plugs into a computer monitor or TV and uses a standard keyboard and mouse.
<b>RDB</b>	Relational database (RDB) is a collective set of multiple data sets organized by tables, records and columns. RDBs use Structured Query Language (SQL), which is a standard user application that provides an easy programming interface for database interaction.
<b>Retrofitting</b>	Retrofitting is the addition of new technology or features to older systems.
<b>RFID</b>	Radio-Frequency Identification (RFID) uses electromagnetic fields to automatically identify and track tags attached to objects.

## S

<b>SaaS</b>	Software as a service (SaaS) is a way of delivering applications over the Internet—as a service. Instead of installing and maintaining software, you simply access it via the Internet, freeing yourself from complex software and hardware management.
<b>Scrum</b>	Scrum is an agile project management framework that helps teams structure and manage their work through a set of values, principles, and practices.
<b>SCL</b>	Serial Clock (SCL) is the clock line, which is used to synchronize all data transfers over the I2C bus.
<b>SDA</b>	Serial Data (SDA) is the data line. The SCL & SDA lines are connected to all devices on the I2C bus.
<b>Sensor</b>	Sensor is a device which detects or measures a physical property and records, indicates, or otherwise responds to it.
<b>Slack</b>	Slack is an instant messaging program designed by Slack Technologies and owned by Salesforce.

<b>SMBus</b>	System Management Bus (SMBus) is a protocol of exchanges between devices for system management. It is often used to monitor parameters.
<b>SPI</b>	Serial Peripheral Interface (SPI) is an interface that enables the serial exchange of data between two devices, one called a master and the other called a slave.
<b>Sprint</b>	Sprint is, especially in software development, a set period of time during which specific tasks must be completed.
<b>Sprint Backlog</b>	Sprint Backlog is composed of the Sprint Goal (why), the set of Product Backlog items selected for the Sprint (what), as well as an actionable plan for delivering the Increment (how).
<b>Sprint Retrospective</b>	Sprint Retrospective is a recurring meeting dedicated to discussing what went well and what can be improved in a sprint. It also gives a chance to recover from a sprint and prepare for the next one.
<b>SQL</b>	Structured Query Language (SQL) is a standardized programming language that is used to manage relational databases and perform various operations on the data in them.

## T

<b>T&amp;M (Time and Materials)</b>	Time and Materials contract requires a client to pay for a contractor's time and money spent on materials. They usually specify an hourly rate plus a markup for materials.
<b>ThingSpeak</b>	ThingSpeak is an IoT analytics platform service that allows you to aggregate, visualize and analyze live data streams in the cloud. ThingSpeak is often used for prototyping and proof of concept IoT systems that require analytics.
<b>ToF</b>	Time-Of-Flight (ToF) is the measurement of the time taken by an object, particle or wave (be it acoustic, electromagnetic, etc.) to travel a distance through a medium.
<b>TPS</b>	Toyota Production System (TPS) is an integrated socio-technical system, developed by Toyota, that comprises its management philosophy and practices.

## U

<b>User Story</b>	User Story is a tool used in Agile software development to capture a description of a software feature from an end-user perspective. A user story is a lightweight method for quickly capturing the “who”, “what” and “why” of a product requirement.
-------------------	---

## V

<b>Visualization</b>	Visualization is an act of making something able to be seen by the eye.
<b>VNC</b>	Virtual Network Computing (VNC) is a cross-platform screen sharing system that was created to remotely control another computer.
<b>VPN</b>	Virtual Private Network (VPN) is a system that uses code to securely access a computer in a different location via the internet.
<b>VR</b>	Virtual Reality (VR) is a set of images and sounds, produced by a computer, that seem to represent a place or a situation that a person can take part in.



## W

<b>Waterfall</b>	Waterfall methodology is a sequential development process that flows like a waterfall through all phases of a project (analysis, design, development, and testing, for example), with each phase completely wrapping up before the next phase begins.
<b>WBS</b>	Work-Breakdown Structure (WBS) in project management and systems engineering is a deliverable-oriented breakdown of a project into smaller components (epics or projects, tasks and subtasks).

## 2. Frequently Asked Questions

**Q1** What is Digital Kaizen in a nutshell?

**A1** This guidebook defines Digital Transformation and Digital Optimization as “the successful implementation by actively integrating rapidly evolving digital technologies into Kaizen activities and fully exploiting their potential” especially for small and medium-sized manufacturing companies.

**Q2** How does Digital Kaizen relate to Digital Transformation (DX)?

**A2** The Japanese Ministry of Economy, Trade and Industry (METI) defines digital transformation as “the transformation of products, services, and business models based on the needs of customers and society, as well as the transformation of operations themselves, organizations, processes, and corporate culture and climate, in order to establish a competitive advantage in response to rapid changes in the business environment, using data and digital technology”. Digital Kaizen is also an activity encompassed by Digital Transformation (DX).

**Q3** What kind of productivity improvements are expected by deploying Digital Kaizen?

**A3** Mainly, visualization through digital data and automation/automation of production processes are expected to be realized. Specifically, “reduction of labor hours by reducing wasteful work,” “improvement of working environment in factories,” “increase of harvest volume by monitoring food growth environment,” “prevention of defective products by automatically stopping production lines,” “visualization of productivity by monitoring production status,” etc. are expected, although these will vary depending on the field of introduction and deployment. These are just a few examples of the expected benefits of Digital Kaizen. Even if labor productivity improves through Digital Kaizen, the objective is not to reduce the workforce, but to secure and develop more productive human resources by optimizing personnel allocation and reskilling (capacity building) of employees.

**Q4** The guidebook mentions that “reskilling as a human resource strategy” is necessary to implement Digital Kaizen, but how should human resources reskilling be deployed?

**A4** There are various ways to proceed depending on company, but the following is a general approach.

- (1) Define human resources and skills based on the business strategy.
- (2) Decide on an education program (e.g., online courses such as e-learning, lectures by outside personnel, etc.)
- (3) Promote employee involvement and introduce motivation measures.
- (4) Implement what has been learned within the company.

**Q5** It is anticipated that employees will object if the increased operational efficiency of Digital Kaizen leads to a reduction in headcount. Are there such concerns?

**A5** Digital Kaizen, like Kaizen in general, aims to improve the way employees work by increasing operational efficiency and improving the work environment, and is not intended to reduce the number of employees. When there is room in the staffing structure, reassignments to new businesses or new business processes can be considered. It is expected to provide opportunities for employees to learn new skills and gain experience.

**Q6** How can generative AI be used in the development of Digital Kaizen?

**A6** Generative AI can be used in a variety of ways in the deployment of Digital Kaizen, including data analysis, problem solving, process optimization, forecasting, and automation. This can improve organizational efficiency and competitiveness.

**Q7** What is difference between Industry 4.0 and Digital Kaizen?

**A7** Industry 4.0 and Digital Kaizen both aim for Digital Transformation in manufacturing but take different approaches. Industry 4.0 aims to increase productivity, flexibility, and agility through automation and digitization of the manufacturing workplace. This approach leverages the latest technologies such as IoT, cloud computing, and AI to optimize the entire manufacturing process. Digital Kaizen, on the other hand, aims to improve productivity and quality using digital technologies in shop floor improvement activities. This approach utilizes technologies such as IoT and big data analysis to identify and improve problems on the shop floor. In a nutshell, Industry 4.0 focuses on optimizing the entire manufacturing process, while Digital Kaizen focuses on improving the shop floor activities.

**Q8** Why does this guidebook recommend Python?

**A8** Python is a good first language for beginners to learn because it allows them to create simple and easy-to-understand programs. The “Pi” in Raspberry Pi is the Pi of Python, and it is said that the computer was built for learning Python, so it is a very compatible programming language.

**Q9** How long does it take to learn Python programming?

**A9** Although it depends on the level you want to learn, it is said that it takes 300 to 400 hours if you study on your own to reach the level of “having a basic understanding of Python and being able to develop simple applications”. If you attend a programming school, you can learn more intensively and efficiently, so 200 hours is probably a good estimate. In addition, Python has program libraries (a collection of classes, functions, etc.) mainly in PyPI, which anyone can freely use. By using the library, you can easily use various programs without having to implement them yourself from scratch.

**Q10** What is the difference between Raspberry Pi and ESP32?

**A10** Raspberry Pi was originally developed for programming education and is equipped with Linux OS and various interfaces, and while it is highly functional, it is over-specified and more expensive than ESP32. ESP32 does not have an OS and cannot be used alone for program development. The programming language is C++, which is difficult for beginners to handle. On the other hand, ESP32 is smaller and less expensive than Raspberry Pi.

**Q11** This guidebook recommends the use of various sensors to perform Digital Kaizen. How much do the sensors cost?

**A11** They are not very expensive, ranging from USD10 to USD100, depending on the manufacturer and performance. The sound sensor and ToF distance sensor shown in the case study are both available for about USD10.

**Q12** How do you use different communication methods such as BLE (Bluetooth Low Energy) and LPWA (Low Power Wide Area)?

**A12** BLE is one of the key technologies supporting the IoT because of its low power consumption, low cost, safety, and wide selection of products equipped with BLE. It also has the advantages of pairing without the need for complicated settings, being a global standard, being highly versatile, and having a wide range of products equipped with BLE. The disadvantage, however, is the short communication distance: Class 1 has a maximum range of 100 m, while Class 2, which is widely used in audio products, has a maximum range of 10 m. Therefore, BLE is used in factories, offices, etc., where the working range is limited. On the other hand, LPWA uses a low-speed narrow bandwidth, allowing radio waves to be transmitted and received over long distances, from several kilometers to more than several tens of kilometers. Therefore, LPWA is often used in cases where environmental sensors or water level sensors are installed over a wide area, such as on a farm, to monitor the situation.

**Q13** This guidebook recommends Scrum as a method for agile development. Can Scrum be used in Kaizen activities?

**A13** Scrum is not a method that can be used only for software development, but also for general Kaizen activities. In Japan, some companies are practicing Scrum as a framework for Kaizen activities.

**Q14** Why doesn't a Scrum Master give instructions or orders?

**A14** A Scrum Master manages the entire project, but instead of commanding and controlling, a Scrum Master should be a servant leader, moving around obstacles to make it easier for members to work. Business decisions are made by the product owner, and decisions about how to develop are made by the team. A Scrum Master helps make those decisions. The key is to create a self-managed team that can make decisions on its own, rather than having a Scrum Master give detailed instructions.

**Q15** Why do you use Fibonacci sequence cards in planning poker?

**A15** It is said that people are better at determining relative magnitudes when compared to other things than at estimating absolute magnitudes. This is because the Fibonacci sequence is suitable for comparing relative magnitudes because the magnitudes of two adjacent numbers are far enough apart to clearly see the difference.

**Q16** Is a Scrum Master always required?

**A16** A Scrum Master is responsible for the way the project is conducted through Scrum and is responsible for helping the product owner and development team to proceed with the project proactively based on the philosophy of Scrum. Therefore, if the product owner and development team can proceed with the project independently based on the philosophy of Scrum, a Scrum Master is not necessarily required.

### 3. Hardware, software, and cloud-based services used in Section 4

Item	Type	Use
Raspberry Pi	Microcontroller	Raspberry Pi runs Linux, allowing you to control electronic components such as sensors and actuators, and explore the Internet of Things (IoT).
ESP32	Microcontroller	ESP32 is a low-cost, low-power system on a chip microcontroller with integrated Wi-Fi and dual-mode Bluetooth.
Python	Programming language	Python is a powerful and versatile programming language that is easy to run the Raspberry Pi.
MDS-F4-5V	Sensor	MDS-F4 is a proximity sensor to be used for positioning of the processing machines, position detection of the moving table and metal pallets, etc.
BME280	Sensor	BME280 is a humidity, pressure and temperature sensor.
BMP280	Sensor	BMP280 is an absolute barometric pressure sensor.
Ambient	Cloud-based service	Ambient is a cloud service to collect, store and visualize sensor data.
InfluxDB	Cloud-based service	InfluxDB is an open source time series database.
GitHub	Cloud-based service	GitHub is a platform and cloud-based service for software development and version control using Git, allowing developers to store and manage their code.
Grafana	Cloud-based service	Grafana is a multi-platform open source analytics and interactive visualization web application.

# LIST OF FIGURES

FIGURE 1-1:	STATUS OF DX INITIATIVE (BY COMPANY SIZE)	5
FIGURE 1-2:	ABILITY TO CONCEPTUALIZE DIGITALIZATION	6
FIGURE 2-1:	TYPICAL STRUCTURE OF IOT [12]	11
FIGURE 2-2:	CONVERSION FROM ANALOG TO DIGITAL [13]	12
FIGURE 2-3:	VARIOUS SENSORS	13
FIGURE 2-4:	MICROCONTROLLERS USED IN IOT	15
FIGURE 2-5:	IOT WIRELESS AREA NETWORK	15
FIGURE 2-6:	LPWA POPULAR STANDARDS	16
FIGURE 2-7:	IOT NETWORKS AT A GLANCE [14]	17
FIGURE 2-8:	FUNCTIONS OF IOT PLATFORM	18
FIGURE 2-9:	CLOUD PROVIDER MARKET SHARE TREND (SOURCE: SYNERGY RESEARCH GROUP) [15]	19
FIGURE 2-10:	COMPARISON OF IOT PLATFORMS	20
FIGURE 2-11:	DATA STORE	21
FIGURE 2-12:	RELATIONAL DATABASE VS. KEY-VALUE DATABASE	22
FIGURE 2-13:	DASHBOARD	24
FIGURE 2-14:	VISUALIZATION TOOLS	24
FIGURE 2-15:	MESSAGING	25
FIGURE 2-16:	PROGRAMMING FOR IOT SYSTEMS	26
FIGURE 2-17:	INTEGRATED DEVELOPMENT ENVIRONMENT (IDE)	28
FIGURE 2-18:	GitHub	29
FIGURE 2-19:	NODE-RED	31
FIGURE 2-20:	AI IN MANUFACTURING	32
FIGURE 2-21:	MAJOR TASKS OF MACHINE VISION	34
FIGURE 2-22:	COMPARISON OF THE ORIGINAL IMAGE WITH DIFFERENT PREPROCESSING RESULTS	36
FIGURE 2-23:	SOBEL OPERATORS	36
FIGURE 2-24:	NEURAL NETWORK ARCHITECTURE DIAGRAM	39
FIGURE 2-25:	THE OPERATION OF MAX POOLING	41
FIGURE 2-26:	THE OPERATION OF MEAN POOLING	42
FIGURE 3-1:	SYSTEM DIAGRAM	48
FIGURE 3-2:	ABNORMALITY NOTIFICATION ON LINE	49

FIGURE 3-3:	RETRIEVING SIGNALS FROM THE FLOW SOLDERING MACHINE	50
FIGURE 3-4:	BUZZER AND SOUND SENSOR FOR AGING FURNACE	50
FIGURE 3-5:	AIR COMPRESSOR AND RECEIVER TANK	51
FIGURE 3-6:	RECEIVER TANK PRESSURE AND AGING FURNACE ALARM	52
FIGURE 3-7:	FLOW SOLDERING MACHINE IN OPERATION	52
FIGURE 3-8:	POSITIONING OF THE PACKAGING PLANT	57
FIGURE 3-9:	PACKAGING PROCESS	57
FIGURE 3-10:	CONCEPTUAL DIAGRAM OF THE PACKAGING LINE	58
FIGURE 3-11:	DIAGRAM OF THE DIGITAL SYSTEM INTRODUCED	59
FIGURE 3-12:	SENSORS AND SENSOR BOARDS	60
FIGURE 3-13:	PRODUCTION MONITORS PLACED ON SITE	60
FIGURE 3-14:	TIME SERIES DATA OF PRODUCTION QUANTITY	61
FIGURE 3-15:	MANAGEMENT OF TARGET AND ACTUAL PERFORMANCE	62
FIGURE 3-16:	REALLOCATION OF PERSONNEL BASED ON DATA	62
FIGURE 3-17:	MAJOR LOCATIONS OF COMPANY C	66
FIGURE 3-18:	OVERALL CONFIGURATION OF THE SYSTEM	68
FIGURE 3-19:	IOT DEVICE CONFIGURATION DIAGRAM	70
FIGURE 3-20:	GATEWAY	71
FIGURE 3-21:	IOT DEVICE	71
FIGURE 3-22:	DEVICE INSTALLED ON THE WALL	72
FIGURE 3-23:	DASHBOARD (DETAIL)	72
FIGURE 3-24:	DASHBOARD (LIST)	73
FIGURE 3-25:	WORKFLOW IN THE HAND TOOL FACTORY	77
FIGURE 3-26:	ARRIVAL OF MATERIALS AT THE FACTORY	78
FIGURE 3-27:	OPERATORS COUNTING MATERIALS	78
FIGURE 3-28:	OPERATORS ESTIMATING QUANTITY BY MEASURING MATERIALS	78
FIGURE 3-29:	PUSHING MATERIAL BOXES INTO STORAGE AREA	79
FIGURE 3-30:	STORAGE AREA	79
FIGURE 3-31:	RECORDING MATERIALS AND LOCATIONS IN THE STORAGE AREA	80
FIGURE 3-32:	HARDWARE SPECIFICATIONS (MPR-2010BN)	81
FIGURE 3-33:	HARDWARE SPECIFICATIONS (HB-1000)	82
FIGURE 3-34:	CREATE AN ORDER	83
FIGURE 3-35:	RFID TAGS	83
FIGURE 3-36:	DATA COMPARISON	84
FIGURE 3-37:	IN-FACTORY RECORD QUERY	84

FIGURE 3-38:	PRODUCTION PROCESS DIAGRAM	88
FIGURE 3-39:	MOTOR CURRENT	89
FIGURE 3-40:	MOTOR STATUS MONITORING FROM OFFICE	90
FIGURE 3-41:	MOTOR MONITORING SYSTEM DIAGRAM	90
FIGURE 3-42:	DRY RUN MOTOR CURRENT	91
FIGURE 3-43:	PRODUCT MANUFACTURING PROCESS	93
FIGURE 3-44:	SYSTEM-RELATED INFORMATION	95
FIGURE 3-45:	INTEGRATION OF INFORMATION SYSTEM WITH AUTOMATION SYSTEM	96
FIGURE 3-46:	STAMPING LINE SCHEMATIC	97
FIGURE 3-47:	RACK DESIGN INTENT	98
FIGURE 3-48:	POWDER COATING LINE SCHEMATIC DIAGRAM	99
FIGURE 3-49:	PACKAGING LINE SCHEMATIC DIAGRAM	100
FIGURE 3-50:	EQUIPMENT OPERATIONAL STATUS	101
FIGURE 4-1:	TARGET SYSTEM	103
FIGURE 4-2:	RASPBERRY PI 4 MODEL B	104
FIGURE 4-3:	RASPBERRY PI FAMILY [70]	105
FIGURE 4-4:	RASPBERRY PI 4 MODEL B INTERFACE	106
FIGURE 4-5:	RASPBERRY PI MODELS	107
FIGURE 4-6:	SELF-DEVELOPMENT	108
FIGURE 4-7:	CROSS-DEVELOPMENT	109
FIGURE 4-8:	CONNECTING PERIPHERALS	110
FIGURE 4-9:	VNC CONCEPTUAL DIAGRAM	112
FIGURE 4-10:	EVENS.PY	124
FIGURE 4-11:	FUNCTION.PY	127
FIGURE 4-12:	PARTS COUNTING SYSTEM CONFIGURATION DIAGRAM	130
FIGURE 4-13:	EXTERNAL VIEW OF THE MDS-F4-5V	130
FIGURE 4-14:	CONNECTION DIAGRAM OF RASPBERRY PI AND PROXIMITY SENSOR	131
FIGURE 4-15:	PROXIMITY.PY	132
FIGURE 4-16:	AVAILABLE ENVIRONMENTAL SENSORS	135
FIGURE 4-17:	CONFIGURATION DIAGRAM OF THE ENVIRONMENTAL PARAMETER ACQUISITION SYSTEM	136
FIGURE 4-18:	BME280 SENSOR MODULE	137
FIGURE 4-19:	CONNECTING THE BME280 TO THE RASPBERRY PI	137
FIGURE 4-20:	I2C INTERFACE [76]	138

FIGURE 4-21:	CREATING A CHANNEL	139
FIGURE 4-22:	I2C CONNECTION CHECK	140
FIGURE 4-23:	OBTAINING A KEY FOR WEBHOOK	141
FIGURE 4-24:	EXECUTE.PY	143
FIGURE 4-25:	CRONTAB FILE	144
FIGURE 4-26:	VISUALIZATION OF ENVIRONMENTAL PARAMETERS	144
FIGURE 4-27:	ANOMALY DETECTION SYSTEM CONFIGURATION DIAGRAM	181
FIGURE 4-28:	PWM	182
FIGURE 4-29:	CONNECTION DIAGRAM OF THE ANOMALY DETECTION SYSTEM	183
FIGURE 4-30:	MEASUREMENT WITHOUT ANOMALY	184
FIGURE 4-31:	MEASUREMENT WITH ANOMALIES	185
FIGURE 4-32:	NORMALIZED CURRENT DATA	186
FIGURE 5-1:	THE DIFFERENCE BETWEEN ANALOG KAIZEN AND DIGITAL KAIZEN	191
FIGURE 5-2:	HOW TO PROCEED WITH PROJECTS USING THE WATERFALL APPROACH AND THE AGILE APPROACH	192
FIGURE 5-3:	DIVISION OF ROLES IN A SCRUM TEAM	195
FIGURE 5-4:	HOW TO PROCEED WITH A SCRUM PROJECT	196
FIGURE 5-5:	SPRINT PLANNING PROCEDURE	202
FIGURE 5-6:	ILLUSTRATION OF PLANNING POKER CARDS	204
FIGURE 5-7:	EXAMPLE OF A TASK BOARD	206
FIGURE 5-8:	EXAMPLE OF A BURNDOWN CHART	206
FIGURE 5-9:	KPT	208
FIGURE 5-10:	EXAMPLE OF THE PURPOSE OF SYSTEMIZATION [64]	208
FIGURE 5-11:	EXAMPLE OF A SYSTEM CONFIGURATION DIAGRAM	209
FIGURE 5-12:	EXAMPLE OF A LIST OF DEVICES USED [65, 66]	210
FIGURE 5-13:	VENDOR SELECTION PROCESS	211
FIGURE 5-14:	CONTRACT TYPES [68]	212

# LIST OF CONTRIBUTORS

<b>Section, Chapter</b>	<b>Name</b>	<b>Designation</b>
Chapter 1.3–1.5, Section 1, Chapter 2.1–2.13, Section 2, Chapter 3.1–3.3, Section 3, Chapter 4.1–4.3 and 4.7, Section 4	Satoshi Komatsu	President Ovum Software Inc.
Chapter 2.14, Section 2	Dr. Tzu-Li Chen	Associate Professor Graduate Institute of Intelligent Manufacturing Technology National Taiwan University of Science and Technology
Chapter 3.4–3.6, Section 3	Dr. Chen-Yang Cheng	Professor Department of Industrial Engineering and Management National Taipei University of Technology
Chapter 4.4–4.6, Section 4	Sadao Kurihara	Representative Director SK Trust Consulting
Section 5	Tatsuo Yoshida	President Yoshida Management Consulting





